

---

## LineRate

- [CLI Reference Guide](#)
- [About This CLI Reference Guide](#)
- [Deprecated CLI Commands](#)
- [CLI General Reference](#)
- [Technical Support](#)
- [Parameter Types](#)
- [IP Address Notation](#)
- [Default Configurations](#)
- [Configure Commands](#)
- [Boot Mode Commands](#)
- [Certificate Mode Commands](#)
- [Exit Command \(config mode\)](#)
- [Failover Mode Commands](#)
- [Failover Group Example](#)
- [Forward Proxy Mode Commands](#)
- [Health Monitor Mode Commands](#)
- [Host Name Mode Commands](#)
- [Interface Mode Commands](#)
- [CARP Example - Active/Standby](#)
- [CARP Example - Active/Active](#)
- [IP Mode Commands](#)
- [Key Mode Commands](#)
- [Licensing Mode Commands \(config\)](#)
- [Load Balancer Mode Commands \(Deprecated\)](#)
- [Logging Mode Commands](#)
- [No Command \(Config Mode\)](#)
- [npm Mode Commands](#)
- [NTP Mode Commands \(config\)](#)
- [Phone Home Mode Commands](#)
- [Proxy Mode Commands](#)
- [Real Server Mode Commands](#)
- [REST Server Mode Commands](#)
- [Scheduler Mode Commands](#)
- [Script Mode Commands](#)
- [SNMP Mode Commands](#)
- [SSH Mode Commands](#)

- [SSL Mode Commands](#)
- [System Mode Commands](#)
- [TCP Mode Commands](#)
- [User Name Mode Commands](#)
- [Virtual IP Mode Commands](#)
- [Virtual Server Mode Commands](#)
- [Exec Commands](#)
- [Backup Mode Commands](#)
- [Bash Mode Commands](#)
- [Clear Mode Commands](#)
- [Configure Command](#)
- [Copy Mode Commands](#)
- [Debug Mode Commands](#)
- [Exit Command \(exec mode\)](#)
- [Halt Mode Commands](#)
- [IP Mode Commands \(exec\)](#)
- [License Mode Commands \(exec\)](#)
- [About Licensing](#)
- [No Command \(exec mode\)](#)
- [NTP Mode Commands \(exec\)](#)
- [Phone Home Mode Commands \(exec\)](#)
- [Reload Mode Commands](#)
- [Restore Mode Commands](#)
- [Scripting Mode Commands](#)
- [Show Commands](#)
- [Show Backup Commands](#)
- [Show Boot Commands](#)
- [Show CARP Commands](#)
- [Show Certificate Commands](#)
- [Show Debug Commands](#)
- [Show Failover Commands](#)
- [Show Forward Proxy Commands](#)
- [Show History Commands](#)
- [Show Interfaces Commands](#)
- [Show IP Commands](#)
- [Show LACP Commands](#)
- [Show Licensing Commands](#)
- [Show Load Balancer Commands \(Deprecated\)](#)
- [Show NTP Commands](#)
- [Show Phone Home Commands](#)
- [Show Port Channel Mode Commands](#)
- [Show Proxy Commands](#)
- [Show Real Server Commands](#)

- [Show REST Server Commands](#)
- [Show Running Config Commands](#)
- [Show Scripting Commands](#)
- [Show Script Commands](#)
- [Show SNMP Commands](#)
- [Show SSL Commands](#)
- [Show Startup Config Commands](#)
- [Show System Commands](#)
- [Show TCP Commands](#)
- [Show Tech Support Commands](#)
- [Show Version Commands](#)
- [Show Virtual IP Commands](#)
- [Show Virtual Server Commands](#)
- [Terminal Mode Commands](#)
- [Upgrade Command](#)
- [Write Command](#)



---

## CLI Reference Guide

---

### Overview

If you are new to F5<sup>®</sup> LineRate<sup>®</sup>, we recommend working through the example configurations in the [Getting Started Guide](#) first.

This guide is a reference for F5<sup>®</sup> LineRate<sup>®</sup> CLI commands.

---

### Contents

The guide is broken into the following sections:

- [About This CLI Reference Guide](#)
- [Deprecated CLI Commands](#)
- [CLI General Reference](#)
- [Configure Commands](#)
- [Exec Commands](#)

---

## About This CLI Reference Guide

1. [Overview](#)
2. [Audience](#)
3. [Conventions](#)
4. [Example IP Addresses](#)
5. [Searching the Guide](#)
  1. [Relevance Level](#)
  2. [Limiting a Search to Specific Tree](#)
  3. [Term Modifiers](#)
    1. [Wildcard Searches](#)
    2. [Fuzzy Searches](#)
    3. [Proximity Searches](#)
    4. [Boosting a Term](#)
  4. [Boolean Operators](#)
    1. [OR](#)
    2. [AND](#)
    3. [+](#)
    4. [NOT](#)
  5. [Grouping](#)
  6. [Escaping Special Characters](#)
6. [Legal Notices](#)
  1. [Copyright](#)
  2. [Trademarks](#)

---

## Overview

This About page contains general information about this guide, including the audience, typographic conventions, and how to search the content.

---





## Audience

This guide is intended for experienced network administrators and network architects who understand your organization's existing TCP/IP network and who need to configure load balancing (reverse proxy) or a forward proxy using F5<sup>®</sup> LineRate<sup>®</sup>.

---

## Conventions

This guide uses the following symbols and typographic conventions.

| Convention   | Definition   |
|--|--|
| <b>Monospaced bold</b>   | Text in a monospaced bold font represents commands or other text that you type exactly as you see it.            |
| <b>&lt;angle bracket&gt;</b>   | Text in a monospaced bold font inside angle brackets represents a placeholder that describes what you must type. |
| <b>[square brackets]</b>   | Text in a monospaced bold font inside square brackets represents an optional command or option.                  |
| Monospaced   | Text in a monospaced font represents output or results the system displays.                                      |
| <b>Bold</b>  | Text in bold shows keys to press and items to select or click, such as menu items or buttons.                    |
|                   | Shows the beginning of a procedure.  |
|  <b>Caution</b> | Cautions contain critical information about configuring your system or data.                                     |
|  <b>Note</b>    | Notes contain important information that may affect how you install or configure your system.                    |
|  <b>Tip</b>     | Tips contain best practices or useful information to help you when configuring your system.                      |
|                 | Shows that the content is for advanced users.  |

---

## Example IP Addresses

Throughout this guide, we use example IP addresses for both internal (private) and external (public) uses.

For private addresses, we use the IP addresses designated in [RFC 1918](#):

- 10.0.0.0 - 10.255.255.255 (10/8 prefix)
- 172.16.0.0 - 172.31.255.255 (172.16/12 prefix)
- 192.168.0.0 - 192.168.255.255 (192.168/16 prefix)

For public addresses, we use the IP addresses designated for documentation in [RFC 5737](#):

- 192.0.2.0/24 (TEST-NET-1)
- 198.51.100.0/24 (TEST-NET-2)
- 203.0.113.0/24 (TEST-NET-3)

---

## Searching the Guide

The search box at the top-right of each page lets you enter a term or phrase to search for. By default, the system searches all pages in the F5<sup>®</sup> LineRate<sup>®</sup> content. Searches are not case sensitive. By default, searches find plurals and other matches from word stems, such as tests, testing, tested, and tester if you search for test.

You can search for a single term such as:

`interface`

Or

`certificate`

You can also search for an exact phrase surrounded by double quotes such as:

`"real server"`

Or

`"IP address"`

---

## Relevance Level

By default, the system sorts the search results by relevance. The relevance is determined by a weighting algorithm that takes into consideration the page title, content, tags, and attachments. The relevance is also affected by the page rating (thumb up or down) and by how often other users select a page to view from similar searches.

Searches can return a large number of results. You can narrow your searches a number of ways by:

- Limiting your search to a specific tree
- Using term modifiers
- Using Boolean operators

---

## Limiting a Search to Specific Tree

If you only want to search one area or tree of a guide, you can limit your search to that tree. For example, if you only want to search the Configure Command tree of the 2.6 Release of the CLI Reference Guide for the term "interface," you can enter your search like this:

```
+(path:087Release_2.6/200CLI_Reference_Guide/Configure_Commands/*) AND interface
```

You can further narrow the search using the term modifiers and Boolean operators (described below):

```
+(path:087Release_2.6/200CLI_Reference_Guide/Configure_Commands/*) AND interface  
AND CARP
```

```
+(path:087Release_2.6/*) AND load AND balancer
```



**Note:** For a tree-specific search, words in quotes are not treated as a specific phrase. The search does an OR search for any words in quotes, so you may not want to use quotes and use AND instead, as shown in the example above.

---

A few steps to help with this type of search:

1. Navigate to the tree you want to search.
2. In your browser's address bar, copy the address of the page.
  - You only need the part after the "<https://docs.lineratesystems.com/>".
3. Using the syntax example above, type in your search and paste in the path of the page you want to search.

---

## Term Modifiers

The search supports modifying query terms to provide a wide range of searching options.

---

### Wildcard Searches

The guides support single- and multiple-character wildcard searches with single terms (not within phrase queries).

To perform a single-character wildcard search, use the ? symbol.

To perform a multiple-character wildcard search, use the \* symbol.

The single-character wildcard search looks for terms that match that with the single character replaced. For example, to search for "text" or "test" you can use the search:

```
te?t
```



The multiple-character wildcard search looks for 0 or more characters. For example, to search for test, tests or tester, you can use the search:

```
test*
```

You can also use the wildcard searches in the middle of a term.

```
te*t
```



**Note:** You cannot use a \* or ? symbol as the first character of a search.

---

## Fuzzy Searches

The guide supports fuzzy searches based on the Levenshtein Distance or Edit Distance algorithm. To do a fuzzy, search use the tilde ~ symbol at the end of a single word. Fuzzy searches work for multiple characters. For example, to search for a term similar in spelling to "roam" use the fuzzy search:

```
roam~
```

This search will find terms like foam and roams.

You can add an optional parameter to specify the required similarity. The value is between 0 and 1. With a value closer to 1, only terms with a higher similarity will be matched. For example:

```
roam~0.6
```

The default is 0.5.

---

## Proximity Searches

The guide supports finding words that are within a specific distance from each other. To do a proximity search, use the tilde ~ symbol at the end of a phrase. For example, to search for a "feature" and "standard" within 10 words of each other in a document use the search:

```
"feature standard"~10
```

---

## Boosting a Term

The guide provides the relevance level of matching documents based on the terms found. To boost a term, use the caret ^ symbol with a boost factor (a number) at the end of the term you are searching. The higher the boost factor, the more relevant the term will be.

Boosting allows you to control the relevance of a document by boosting its term. For example, if you are searching for:

```
mindtouch search
```

and you want the term "mindtouch" to be more relevant boost it using the ^ symbol along with the boost factor next to the term. You would type:

```
mindtouch^4 search
```

This will make documents with the term mindtouch appear more relevant. You can also boost phrases as in the example:

```
"mindtouch search"^4 "Apache"
```

By default, the boost factor is 1. Although the boost factor must be positive, it can be less than 1 (e.g. 0.2)

---

## Boolean Operators

Boolean operators allow terms to be combined through logic operators. MindTouch supports AND, +, OR, NOT, and - as Boolean operators.



**Note:** Boolean operators must be ALL CAPS.

---

### OR

The OR operator is the default conjunction operator. This means that if there is no Boolean operator between two terms, the OR operator is used. The OR operator links two terms and finds a matching document if either of the terms exist in a document. This is equivalent to a union using sets. The symbol || can be used in place of the word OR.

To search for documents that contain either "mindtouch search" or just "mindtouch" use the query:

```
"mindtouch search" mindtouch
```

or

```
"mindtouch search" OR mindtouch
```

---

### AND

The AND operator matches documents where both terms exist anywhere in the text of a single document. This is equivalent to an intersection using sets. You can use the symbol && in place of the word AND.

To search for documents that contain "mindtouch search" and "Advanced" use the query:

```
"mindtouch search" AND "Advanced"
```

---

## +

The + (required operator) requires that the term after the + symbol exist somewhere in a document.

To search for documents that must contain "search" and may contain "advanced," use the query:

```
+search advanced
```

---

## NOT

The NOT operator excludes documents that contain the term after NOT. This is equivalent to a difference using sets. You can use the symbol ! in place of the word NOT.

To search for documents that contain "mindtouch search" but not "Advanced" use the query:

```
"mindtouch search" NOT "Advanced"
```

---



**Note:** The NOT operator cannot be used with just one term. For example, the following search will return no results:

```
NOT "mindtouch search"
```

---

---

## Grouping

The guide supports using parentheses to group clauses to form sub queries. This can be very useful if you want to control the Boolean logic for a query.

To search for either "mindtouch" or "search" and "advanced" use the query:

```
(mindtouch OR search) AND advanced
```

This eliminates any confusion and makes sure you that website must exist and either term mindtouch or search may exist.

---

## Escaping Special Characters

The Guide supports escaping special characters that are part of the query syntax. The current list of special characters is:

```
+ - && || ! ( ) { } [ ] ^ " ~ * ? : \
```

To escape these character use the \ before the character. For example, to search for (1+1):2 use the query:

```
\(1\+1\)\:2
```

---

# Legal Notices

---

## Copyright

Copyright © 2015, F5 Networks, Inc. All rights reserved.

F5 Networks, Inc. (F5) believes the information it furnishes to be accurate and reliable. However, F5 assumes no responsibility for the use of this information, nor any infringement of patents or other rights of third parties which may result from its use. No license is granted by implication or otherwise under any patent, copyright, or other intellectual property right of F5 except as specifically described by applicable user licenses. F5 reserves the right to change specifications at any time without notice.

---

## Trademarks

AAM, Access Policy Manager, Advanced Client Authentication, Advanced Firewall Manager, Advanced Routing, AFM, APM, Application Acceleration Manager, Application Security Manager, ARX, AskF5, ASM, BIG-IP, BIG-IQ, Cloud Extender, CloudFucious, Cloud Manager, Clustered Multiprocessing, CMP, COHESION, Data Manager, DevCentral, DevCentral [DESIGN], DNS Express, DSC, DSI, Edge Client, Edge Gateway, Edge Portal, ELEVATE, EM, Enterprise Manager, ENGAGE, F5, F5 [DESIGN], F5 Certified [DESIGN], F5 Networks, F5 SalesXchange [DESIGN], F5 Synthesis, f5 Synthesis, F5 Synthesis [DESIGN], F5 TechXchange [DESIGN], Fast Application Proxy, Fast Cache, FirePass, Global Traffic Manager, GTM, GUARDIAN, iApps, IBR, Intelligent Browser Referencing, Intelligent Compression, IPv6 Gateway, iControl, iHealth, iQuery, iRules, iRules OnDemand, iSession, L7 Rate Shaping, LC, Link Controller, Local Traffic Manager, LineRate, LineRate Precision, LineRate Systems [DESIGN], LROS, LTM, Message Security Manager, MSM, OneConnect, Packet Velocity, PEM, Policy Enforcement Manager, Point Load Balancer, Protocol Security Manager, PSM, Real Traffic Policy Builder, SalesXchange, ScaleN, Signalling Delivery Controller, SDC, SSL Acceleration, software designed applications services, SDAC (except in Japan), StrongBox, SuperVIP, SYN Check, TCP Express, TDR, TechXchange, TMOS, TotALL, Traffic Management Operating System, Traffix Systems, Traffix Systems (DESIGN), Transparent Data Reduction, UNITY, VAULT, vCMP, VE F5 [DESIGN], Versafe, Versafe [DESIGN], VIPRION, Virtual Clustered Multiprocessing, WebSafe, and ZoneRunner, are trademarks or service marks of F5 Networks, Inc., in the U.S. and other countries, and may not be used without F5's express written consent.

All other product and company names herein may be trademarks of their respective owners.

## Deprecated CLI Commands

1. [Overview](#)
2. [Deprecated CLI Commands](#)
  1. [Release 2.6](#)
  2. [Release 2.5](#)
  3. [Release 2.4](#)
  4. [Release 2.3](#)
  5. [Release 2.2](#)
  6. [Release 2.0](#)

## Overview

This section describes the commands deprecated in previous releases.

## Deprecated CLI Commands

### Release 2.6

The following CLI commands were deprecated in F5<sup>®</sup> LineRate<sup>®</sup> release 2.6:

| Mode   | Deprecated command  | Replaced by   |
|--------|---|---|
| config | <code>username &lt;username&gt; secret clear &lt;password&gt; [uid &lt;userid&gt;]</code>     | <a href="#">username</a> <username><br><br>secret clear<br><password><br><br>[uid <userid>] |
| config | <code>username &lt;username&gt; secret encrypted &lt;password&gt; [uid &lt;userid&gt;]</code> | <a href="#">username</a> <username><br><br>secret<br>encrypted <password>                   |

| Mode | Deprecated command | Replaced by    |
|------|--------------------|----------------|
|      |                    | [uid <userid>] |

---

## Release 2.5

The following CLI commands were deprecated in F5<sup>®</sup> LineRate<sup>®</sup> release 2.5:

| Mode               | Deprecated command  | Replaced by                                    |
|--------------------|---|--|
| config-ssl-profile | <code>attach primary-certificate &lt;cert_name&gt;</code> | <a href="#">attach</a> certificate <cert_name> |
| config-ssl-profile | <code>attach private-key &lt;key_name&gt;</code>          | <a href="#">attach</a> key <key_name>          |

---

## Release 2.4

No CLI commands were deprecated in F5<sup>®</sup> LineRate<sup>®</sup> release 2.4.

---

## Release 2.3

The following CLI commands were deprecated in F5<sup>®</sup> LineRate<sup>®</sup> release 2.3:

| Mode                | Deprecated command                                | Replaced by   |
|---------------------|---|---|
| config-npm-registry | <code>attach certificate &lt;cert_name&gt;</code> | <a href="#">attach</a> certificate bundle <bundle_name> |

---

## Release 2.2

No CLI commands were deprecated in F5<sup>®</sup> LineRate<sup>®</sup> release 2.2.

---

## Release 2.0

The following CLI commands were deprecated in F5<sup>®</sup> LineRate<sup>®</sup> release 2.0:

| <b>Mode</b> | <b>Deprecated command</b> | <b>Replaced by</b>         | <b>Notes</b>  |
|-------------|---------------------------|----------------------------|---|
| config      | <b>load-balancer</b>      | <a href="#">proxy</a>      | If you load a configuration from release 1.6 or earlier that uses the load-balancer command on a 2.x system and save the configuration, the system automatically migrates the command to the replacement command. |
| exec        | <b>show load-balancer</b> | <a href="#">show proxy</a> |   |



---

## CLI General Reference

---

### Overview

This section describes information that applies throughout the rest of the *CLI Reference Guide*. It contains information about the CLI parameter types and other information that applies to using many CLI commands in the following sections:

- [Technical Support](#)
- [Parameter Types](#)
- [IP Address Notation](#)

Also see the following:

- [Accessing the LineRate CLI](#)
- [Using the Command Line Interface](#)





---

## Technical Support

Support tools are available to help you answer your questions whenever and wherever you need help. From the documentation to the global technical community you can collaborate with on DevCentral, F5<sup>®</sup> LineRate<sup>®</sup> self-service tools help you solve issues quickly and proactively.

The [LineRate Support page](#) can help you find the resources you need.

## Parameter Types

- [Parameter Type Definitions](#)

## Parameter Type Definitions

The table below defines the parameter types used throughout the *CLI Reference Guide*.

| Parameter type | Definition  |               |                      |    |   |    |   |    |   |    |   |    |                             |    |           |
|----------------|---|---------------|----------------------|----|---|----|---|----|---|----|---|----|-----------------------------|----|-----------|
| Integer        | An optional + or - sign followed by one or more digits (0-9).   |               |                      |    |   |    |   |    |   |    |   |    |                             |    |           |
| Real           | Everything an Integer can be and can also include a decimal point and more digits after the decimal point.  |               |                      |    |   |    |   |    |   |    |   |    |                             |    |           |
| Word           | A string that can be made up only of letters (upper or lower), digits, dashes, and periods. Quotes around a Word are not accepted.  |               |                      |    |   |    |   |    |   |    |   |    |                             |    |           |
| String         | <ul style="list-style-type: none"> <li>Can be a Word, in which case no quotation marks should be used.</li> <li>Can be a string of any ASCII printable characters -- except for four characters ' " \ ? -- which must be surrounded by double quotation marks. In a few cases the exceptions are permitted; this is noted in the documentation for those cases.</li> </ul>  |               |                      |    |   |    |   |    |   |    |   |    |                             |    |           |
| EscString      | <p>Can be a string and can contain the escape strings listed below.</p> <table border="1"> <thead> <tr> <th>Escape string</th> <th>Translated character</th> </tr> </thead> <tbody> <tr> <td>\'</td> <td>'</td> </tr> <tr> <td>\"</td> <td>"</td> </tr> <tr> <td>\\</td> <td>\</td> </tr> <tr> <td>\?</td> <td>?</td> </tr> <tr> <td>\a</td> <td>Alarm (bell) – audible tone</td> </tr> <tr> <td>\b</td> <td>Backspace</td> </tr> </tbody> </table> | Escape string | Translated character | \' | ' | \" | " | \\ | \ | \? | ? | \a | Alarm (bell) – audible tone | \b | Backspace |
| Escape string  | Translated character  |               |                      |    |   |    |   |    |   |    |   |    |                             |    |           |
| \'             | '   |               |                      |    |   |    |   |    |   |    |   |    |                             |    |           |
| \"             | "   |               |                      |    |   |    |   |    |   |    |   |    |                             |    |           |
| \\             | \   |               |                      |    |   |    |   |    |   |    |   |    |                             |    |           |
| \?             | ?   |               |                      |    |   |    |   |    |   |    |   |    |                             |    |           |
| \a             | Alarm (bell) – audible tone   |               |                      |    |   |    |   |    |   |    |   |    |                             |    |           |
| \b             | Backspace   |               |                      |    |   |    |   |    |   |    |   |    |                             |    |           |

| Parameter type | Definition   |  |               |                      |    |           |    |           |    |                 |    |     |    |              |
|----------------|--|--|---------------|----------------------|----|-----------|----|-----------|----|-----------------|----|-----|----|--------------|
|                | <table border="1" data-bbox="329 279 943 625"> <thead> <tr> <th data-bbox="329 279 558 331">Escape string</th> <th data-bbox="558 279 943 331">Translated character</th> </tr> </thead> <tbody> <tr> <td data-bbox="329 331 558 394">\f</td> <td data-bbox="558 331 943 394">Form feed</td> </tr> <tr> <td data-bbox="329 394 558 457">\n</td> <td data-bbox="558 394 943 457">Line feed</td> </tr> <tr> <td data-bbox="329 457 558 520">\r</td> <td data-bbox="558 457 943 520">Carriage return</td> </tr> <tr> <td data-bbox="329 520 558 573">\t</td> <td data-bbox="558 520 943 573">Tab</td> </tr> <tr> <td data-bbox="329 573 558 625">\v</td> <td data-bbox="558 573 943 625">Vertical tab</td> </tr> </tbody> </table> |  | Escape string | Translated character | \f | Form feed | \n | Line feed | \r | Carriage return | \t | Tab | \v | Vertical tab |
| Escape string  | Translated character   |  |               |                      |    |           |    |           |    |                 |    |     |    |              |
| \f             | Form feed  |  |               |                      |    |           |    |           |    |                 |    |     |    |              |
| \n             | Line feed  |  |               |                      |    |           |    |           |    |                 |    |     |    |              |
| \r             | Carriage return  |  |               |                      |    |           |    |           |    |                 |    |     |    |              |
| \t             | Tab  |  |               |                      |    |           |    |           |    |                 |    |     |    |              |
| \v             | Vertical tab   |  |               |                      |    |           |    |           |    |                 |    |     |    |              |
| IPv4Addr       | IP address in IPv4 dotted decimal notation (aaa.bbb.ccc.ddd). Depending on the context, this could be a single host address, an IP subnet, or an IP subnet mask.   |  |               |                      |    |           |    |           |    |                 |    |     |    |              |
| IPv6Addr       | IP address in IPv6 notation per <a href="http://tools.ietf.org/html/rfc2373">http://tools.ietf.org/html/rfc2373</a> section 2.2. For IPv6, this always refers to a single host address.  |  |               |                      |    |           |    |           |    |                 |    |     |    |              |
| IPAddr         | Either an IPv4Addr or IPv6Addr.  |  |               |                      |    |           |    |           |    |                 |    |     |    |              |
| IPv4AddrMask   | IPv4 host address and mask or IP subnet (that is, range of hosts) in CIDR notation (aaa.bbb.ccc.ddd/mm). See <a href="http://en.wikipedia.org/wiki/CIDR">http://en.wikipedia.org/wiki/CIDR</a> .   |  |               |                      |    |           |    |           |    |                 |    |     |    |              |
| IPv6AddrMask   | IPv6 host address and mask or IP subnet (that is, range of hosts) in CIDR notation, see <a href="http://tools.ietf.org/html/rfc2373">http://tools.ietf.org/html/rfc2373</a> section 2.3.   |  |               |                      |    |           |    |           |    |                 |    |     |    |              |
| IPAddrMask     | Either an IPv4AddrMask or IPv6AddrMask.  |  |               |                      |    |           |    |           |    |                 |    |     |    |              |

---

## IP Address Notation

F5<sup>®</sup> LineRate<sup>®</sup> supports both IPv4 and IPv6. You can specify the IP address and subnet mask in any of the following formats:

- `192.0.2.1/24`— example of an IPv4 address with a 24-bit subnet mask using CIDR notation.
- `192.0.2.1 255.255.255.0`—equivalent to above using net mask notation.
- `2001:DB8::/64`—example of an IPv6 address with a 64 bit subnet mask using CIDR notation.

If you need more information about IP addresses and subnet masks, see these sites for more information:

- [http://en.wikipedia.org/wiki/IP\\_address](http://en.wikipedia.org/wiki/IP_address)
- [http://en.wikipedia.org/wiki/CIDR\\_notation](http://en.wikipedia.org/wiki/CIDR_notation)

---

## Default Configurations

1. [Overview](#)
2. [Forward Proxy](#)
3. [Health Monitor](#)
4. [Host Name](#)
5. [Interface](#)
6. [Logging Server](#)
7. [Proxy Processes](#)
8. [Real Server](#)
9. [REST Server](#)
10. [Script](#)
11. [SNMP](#)
12. [SSH](#)
13. [Virtual IP](#)
14. [Virtual Server](#)

---

## Overview

This page is meant for use as a quick reference guide to the default configuration parameters (also referred to as implied defaults) for F5<sup>®</sup> LineRate Precision<sup>™</sup> Load Balancer and F5<sup>®</sup> LineRate Point<sup>™</sup> Load Balancer.



The default settings listed on this page will not show up in `startup-config` or `running-config` unless manually configured with non-default values.

---

---

## Forward Proxy

| Parameter    | Default Value | Comments |
|--------------|---------------|----------|
| admin-status | offline       |          |

|                                       |             |   |
|---------------------------------------|-------------|---|
| mode                                  | transparent |   |
| service                               | http        | Service HTTP is the default service type if none is manually specified. |
| service http<br>keepalive-<br>timeout | 0           | disabled  |
| request-rate-<br>limit                | 0           | no limit  |

### Related

CLI Reference - [Forward Proxy Mode Commands](#)

REST API Reference - [forwardProxy](#)

---

## Health Monitor

| Parameter          | Default Value | Comments   |
|--------------------|---------------|--|
| interval           | 10 seconds    |  |
| logging            | disabled      | Setting logging on health monitors has potential to degrade service on busy, high-traffic F5 <sup>®</sup> LineRate <sup>®</sup> instances. |
| server-down        | 1/10          |  |
| server-up          | 2/2           |  |
| timeout            | 3 seconds     |  |
| type http          | HEAD request  |  |
| request-<br>method | HEAD          |  |
| request-target     | /             |  |

|                 |        |  |
|-----------------|--------|--|
| response-status | 200 OK |  |
|-----------------|--------|--|

### Related

CLI Reference - [Health Monitor Mode Commands](#)

REST API References - [health](#), [monitor](#)

---

## Host Name

| Parameter | Default Value | Comments |
|-----------|---------------|----------|
| host-name | LROS          |          |

### Related

CLI Reference - [Host Name Mode Commands](#)

REST API Reference - [hostname](#)

| Parameter    | Default Value | Comments |
|--------------|---------------|----------|
| admin-status | offline       |          |
| timeout      | 3 seconds     |          |
| retries      | 1             |          |

### Related

CLI Reference - [IP Mode Commands](#)

REST API Reference - [dns](#)

---

## Interface

| Parameter | Default Value | Comments |
|-----------|---------------|----------|
|-----------|---------------|----------|

|     |      |                            |
|-----|------|----------------------------|
| mtu | 1500 | loopback defaults to 16384 |
|-----|------|----------------------------|

### Related

CLI Reference - [Interface Mode Commands](#)

REST API References - [proxy](#), [interface](#), [mtu](#)

---

## Logging Server

| Parameter | Default Value | Comments |
|-----------|---------------|----------|
| port      | 514           |          |
| protocol  | udp           |          |

### Related

CLI Reference Guide - [Logging Mode Commands](#)

REST API Reference - [port](#)

---

## Proxy Processes

| Parameter | Default Value | Comments   |
|-----------|---------------|--|
| processes | auto          | This is auto-tuned to the largest value supported by the system. |

### Related

CLI Reference - [Proxy Mode Commands](#)

REST API Reference - [proxy](#), [processes](#)

---

## Real Server

| Parameter | Default Value | Comments |
|-----------|---------------|----------|
|-----------|---------------|----------|



|                        |                  |   |
|------------------------|------------------|---|
| admin-status           | offline          |   |
| attach                 | nothing attached |   |
| base                   | none             |   |
| description            | none             |   |
| ip address             | none             |   |
| max-connections        | 0                | Default setting results in permitting up to 64,511 connections. |
| service                | http             | HTTP is the default service type if none is manually specified. |
| keepalive-timeout      | 0                | disabled  |
| max-in-flight          | 1                |   |
| request-idle-timeout   | 0                | disabled  |
| request-rate-limit     | 0                | no limit  |
| response-idle-timeout  | 0                | disabled  |
| response-timeout       | 0                | disabled  |
| tunnel<br>idle-timeout | 0                | disabled; only on HTTP real servers                             |
| data<br>idle-timeout   | 0                | disabled; only on TCP real servers                              |

## Related

CLI Reference - [Real Server Mode Commands](#)

REST API Reference - [realServer](#)

---

## REST Server

| Parameter     | Default Value         | Comments |
|---------------|-----------------------|----------|
| allow-to-port | 8443                  |          |
| logging       | off                   |          |
| idle-timeout  | 3600 seconds (1 hour) |          |

### Related

CLI Reference - [REST Server Mode Commands](#)

REST API Reference - [restServer](#)

---

## Script

| Parameter          | Default Value                  | Comments |
|--------------------|--------------------------------|----------|
| admin-status       | offline                        |          |
| restart-mode       | auto                           |          |
| certificate-bundle | system-root-certificate-bundle |          |

### Related

CLI Reference - [Script Mode Commands](#)

REST API Reference - [script](#)

---

## SNMP

| Parameter | Default Value | Comments |
|-----------|---------------|----------|
|-----------|---------------|----------|

|                                    |        |   |
|------------------------------------|--------|---|
| community                          | public | This community is Read-Only by default.   |
| contact                            | none   |   |
| port                               | 161    |   |
| host<br><name><br><br>udp-<br>port | 162    | This default port is used after the "enable udpv4" command has been configured. |
| location                           | none   |   |

### Related

CLI Reference - [SNMP Mode Commands](#)

REST API Reference - [snmp](#)

---

## SSH

| Parameter     | Default Value | Comments |
|---------------|---------------|----------|
| allow-to-port | 22            |          |

### Related

CLI Reference - [SSH Mode Commands](#)

REST API Reference - [ssh](#)

---

## Virtual IP

| Parameter    | Default Value | Comments |
|--------------|---------------|----------|
| admin-status | offline       |          |

|                         |            |   |
|-------------------------|------------|---|
| incoming-queue-length   | 0          | Infinite; limited only by system RAM.                           |
| max-embryonic-conns     | 0          | Disabled; embryonic connections are not limited by default.     |
| service                 | http       | HTTP is the default service type if none is manually specified. |
| keepalive-timeout       | 10 seconds |   |
| max-in-flight           | 1          |   |
| max-request-header-size | 32 KB      |   |

## Related

CLI Reference - [Virtual IP Mode Commands](#)

REST API Reference - [virtualIP](#)

---

## Virtual Server

| Parameter                           | Default Value    | Comments  |
|-------------------------------------|------------------|---|
| lb-algorithm                        | round-robin-free |   |
| service http                        | http             | HTTP is the default service type if none is manually specified. |
| keepalive-timeout                   | 0                | disabled  |
| request-rate-limit                  | 0                | no limit  |
| persist source-ip idle-timeout      | 300 seconds      | Idle timeout for entry in persist table.                        |
| persist ssl-session-id idle-timeout | 300 seconds      | Idle timeout for entry in persist table.                        |

|  |             |  |
|--|-------------|--|
| persist cookie<br><name> expires                     | 0           | no expiration; the cookie will still expire when the session ends. |
| service tcp<br><br>persist source-ip<br>idle-timeout | 300 seconds | Idle timeout for entry in persist table.                           |
| persist ssl-session-<br>id idle-timeout              | 300 seconds | Idle timeout for entry in persist table.                           |
| persist data-idle-<br>timeout                        | 1 second    | This setting only applies to SSL-session-ID persistence mode.      |

## Related

CLI Reference - [Virtual Server Mode Commands](#)

REST API Reference - [virtualServer](#)



---

## Configure Commands

---

### Overview

If you are new to F5<sup>®</sup> LineRate<sup>®</sup>, we recommend working through the example configurations in the [Getting Started Guide](#) first.

This section is a reference for F5<sup>®</sup> LineRate<sup>®</sup> CLI configure commands.

---

### Contents

The guide is broken into the following sections:

- [Boot Mode Commands](#)
- [Certificate Mode Commands](#)
- [Exit Command \(config mode\)](#)
- [Failover Mode Commands](#)
- [Forward Proxy Mode Commands](#)
- [Health Monitor Mode Commands](#)
- [Host Name Mode Commands](#)
- [Interface Mode Commands](#)
- [IP Mode Commands](#)
- [Key Mode Commands](#)
- [Licensing Mode Commands \(config\)](#)
- [Load Balancer Mode Commands \(Deprecated\)](#)
- [Logging Mode Commands](#)
- [No Command \(Config Mode\)](#)
- [npm Mode Commands](#)
- [NTP Mode Commands \(config\)](#)
- [Phone Home Mode Commands](#)
- [Proxy Mode Commands](#)
- [Real Server Mode Commands](#)
- [REST Server Mode Commands](#)
- [Scheduler Mode Commands](#)
- [Script Mode Commands](#)

- [SNMP Mode Commands](#)
- [SSH Mode Commands](#)
- [SSL Mode Commands](#)
- [System Mode Commands](#)
- [TCP Mode Commands](#)
- [User Name Mode Commands](#)
- [Virtual IP Mode Commands](#)
- [Virtual Server Mode Commands](#)

---

## Boot Mode Commands

---

### boot

Configure version to use to reload the system.

#### Use

Whenever you upgrade F5<sup>®</sup> LineRate<sup>®</sup>, the system retains the previous version, including all configuration settings at the time of the upgrade. If needed, you can reload any previous version by setting the version you want to reload using the boot command.

To see the previous versions available, use the following commands:

```
bash "ls /base/persist"
```



Be sure to use **write** to save your change after using the boot command, then use **reload** to actually reload to the specified version.

---

#### Default Setting

Current system software version

#### Command Mode

configure

#### Syntax

```
boot system <version>
```

Configure version to reload

| Parameter | Type   | Description       |
|-----------|--------|-------------------|
| version   | String | Version to reload |

#### Related Commands



[Reload Mode Commands](#)

[Upgrade Command](#)

REST API Reference - [boot](#)

---

## Certificate Mode Commands

Use the following commands to configure certificates.

1. [Overview](#)
2. [certificate](#)
  1. [pem-format](#)
3. [certificate bundle](#)
  1. [file-path](#)
  2. [pem-format](#)

---

## Overview

F5® LineRate® comes with the following certificates:

- Self-signed certificate for use testing SSL.
- System root certificate bundle for general system use and for attaching to scripts and to nmp registries.

---

## certificate

Create or modify a certificate.

### Use

Use to configure certificates for use with SSL. Example uses of certificates are for performing SSL offload by attaching to a virtual IP or for management access to the system by attaching to the REST server.

To set up certificates, you must have access to your certificate files. The F5® LineRate® software supports PEM format certificates.



### Best Practices:

- Give each certificate a meaningful name that helps identify the certificate. For example, you might use the domain name or security settings in the name.
  - Configure primary certificates and corresponding keys for each cipher type that clients may use, then attach the configured certificate/key pairs to the SSL profile. For example, for clients that
-

---

support ECC or RSA ciphers, you may want to configure and attach both RSA and ECC certificates and keys.

---

For more information about certificates, see [Managing SSL](#).

### Default Setting

By default, the system creates a key, certificate, and SSL profile, each called self-signed, that you can use to test the SSL function.

### Command Mode

configure

### Syntax

```
[no] certificate <cert_name>
```

Create or modify a single primary or chain certificate

| Parameter | Type | Description             |
|-----------|------|-------------------------|
| cert_name | Word | Name of the certificate |

### Example

See [Setting Up Certificates for SSL Termination](#).

### Related Commands

[Key Mode Commands](#)

[SSL Mode Commands](#)

REST API Reference - [certificates](#)

---

## pem-format

Specify the certificate content in a PEM-encoded (base64) string.

### Use

Use to paste certificate text into a single certificate.

- CLI command—After entering the command, press **Enter** to paste certificate text. Type **quit** to finish.
- REST API—Paste the certificate text into the data key.

## Default Setting

None

## Command Mode

config-certificate

## Syntax

`pem-format`

Specify the certificate content in a PEM-encoded (base64) encoded string.

## Example

See [Setting Up Certificates for SSL Termination](#).

## Related Commands

[Key Mode Commands](#)

[SSL Mode Commands](#)

---

# certificate bundle

Create or modify a certificate bundle.

## Use

Use to configure certificate bundles for use as:

- Chain certificate bundle for SSL—Example uses of chain certificate bundles are for performing SSL offload by attaching to a virtual IP or for management access to the system by attaching to the REST server.
- Certificate bundle for a script—Attach a certificate bundle to a script.
- Certificate bundle for an npm registry—Attach a certificate bundle to an npm registry.
- System root certificate bundle—Replace the default system root certificate bundle.

Give each certificate a meaningful name that helps identify the certificate. For example, you might use the domain name or security settings in the name.

### *SSL Chain Certificate Bundles*

The system lets you attach one or more private keys, primary certificates, individual chain certificates, as well as certificate bundles to an SSL profile. Each chain certificate identifies an intermediate Certificate Authority (CA) that can authenticate a primary certificate for the profile.

A certificate bundle is a single file that contains multiple chain certificates concatenated together. The bundle can include related and unrelated chain certificates. The system automatically looks for the chain certificates that correspond to a primary certificate.

For more information about certificate bundles, see [Working with Certificate Bundles](#).

## Default Setting

By default, the system comes with a system root certificate bundle for general system use.

## Command Mode

configure

## Syntax

```
[no] certificate bundle <bundle_name>
```

Create or modify a certificate bundle of chain certificates

| Parameter   | Type | Description                    |
|-------------|------|--------------------------------|
| bundle_name | Word | Name of the certificate bundle |

## Related Commands

[Key Mode Commands](#)

[npm Mode Commands](#)

[Script Mode Commands](#)

[SSL Mode Commands](#)

[System Mode Commands](#)

REST API Reference - [certificateBundles](#)

---

## file-path

Specify file path to use for the certificate bundle.

### Use

Use to configure a certificate bundle from an existing file. The file can contain one or more PEM-formatted certificates.

Place the certificate bundle file in the /home/linerate/data/certificate-bundle directory.

### Default Setting

None

### Command Mode

config-cert-bundle

### Syntax

`no file-path`

Remove file path and name from for the certificate bundle.

`[no] file-path <file_str>`

Specify path name to file which should be used to configure certificate bundle.

| Parameter | Type   | Description   |
|-----------|--------|---|
| file_str  | String | Path names can be absolute (for example, "/home/linerate/data/certificate-bundle/mybundle.crt") or relative to the certificate bundle home directory /home/linerate/data/certificate-bundle (for example, "mybundle.crt"). Protect path name with quotes. |

---

## pem-format

Specify the certificate content in a PEM-encoded (base64) string.

### Use

Use to paste certificate text into a certificate bundle.

- CLI command—After entering the command, press **Enter** to paste certificate text. Paste several times to add multiple chain certificates to a bundle. Type **quit** to finish.
- REST API—Paste the certificate text into the data key. Paste several times to add multiple certificates to a bundle.

### Default Setting

None

### Command Mode

config-cert-bundle

## **Syntax**

`[no] pem-format`

Specify the certificate bundle content in a PEM (base64) encoded string.

---

## Exit Command (config mode)

### Use

Use to exit the current config mode. When in config mode, this takes you back one mode level. The config mode prompt includes the config mode you are in. When you first go into config mode, the prompt looks like this:

```
LROS (config) #
```

For information about modes, see [Command Line Modes](#).

### Default Setting

None

### Command Mode

config

### Syntax

```
exit
```

### Examples

If you are in configure real server HTTP service mode for a real server called rs1:

```
LROS (config-rserver-http:rs1) #
```

then enter `exit`, you will go back one mode to configure real server mode:

```
LROS (config-rserver-http:rs1) # exit
```

```
LROS (config-rserver:rs1) #
```



---

## Failover Mode Commands

1. [failover](#)
  1. [description](#)

---

### failover

#### Use

Use to create a failover group that you attach to CARP interfaces. Failover groups complement CARP groups. Failover groups provide failover protection for a complete path from clients that use a specific virtual IP to the web servers accessed by that virtual IP. Failover groups provide failover protection for the path on a single F5<sup>®</sup> LineRate<sup>®</sup> system, while CARP groups provide failover protection for one segment of the path across multiple F5<sup>®</sup> LineRate<sup>®</sup> systems.

For a failover group example, see [Failover Group Example](#).



**Note:** For Amazon EC2 instances, failover groups are not supported.

---

#### Default Setting

None

#### Command Mode

config

#### Syntax

```
[no] failover group <group_name>
```

Create or modify a failover group

| Parameter  | Type | Description                |
|------------|------|----------------------------|
| group_name | Word | Name of the failover group |

#### Related Commands

## description

### Use

Use to create a description of the failover group.

### Default Setting

None

### Command Mode

config-failover-group

### Syntax

`[no] description <desc>`

Description for this failover group

`no description`

Removes the description for this failover group

| Parameter | Type   | Description        |
|-----------|--------|--------------------|
| desc      | String | Description string |

---

## Failover Group Example

1. [Failover Group Overview](#)
2. [What You Need](#)
3. [How the Configuration Works](#)
4. [Annotated Configuration](#)
5. [Example Show Run Output](#)

---

## Failover Group Overview



**Note:** For Amazon EC2 instances, failover groups are not supported.

---

You attach failover groups to CARP interfaces. Failover groups complement CARP groups. Failover groups provide failover protection for a complete path from clients that use a specific virtual IP to the web servers accessed by that virtual IP.

Configuring failover groups on CARP groups permits failover for a complete data path between two or more F5<sup>®</sup> LineRate<sup>®</sup> systems. This example shows an active/standby configuration where CARP is configured on the both the outside interfaces (client access) and the inside interfaces (to your servers). In addition, the same failover group (fg1) is configured on each CARP group on both systems.

In the active/standby configuration (shown below), the CARP groups on one F5<sup>®</sup> LineRate<sup>®</sup> system are configured as the active groups, based on their lower priority. The other F5<sup>®</sup> LineRate<sup>®</sup> system is configured identically, except the CARP groups have a higher priority, making that system the standby.

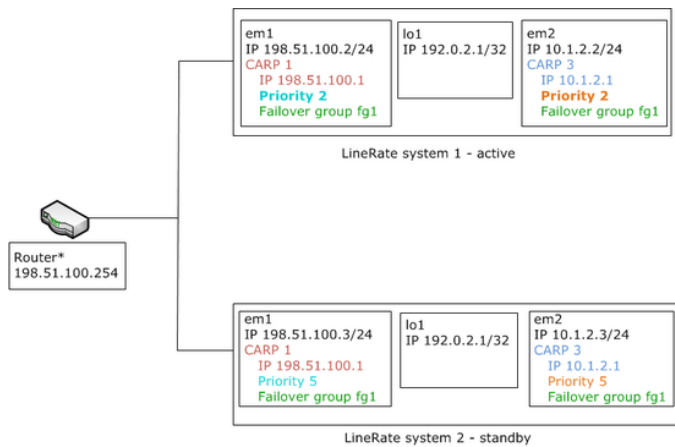

\* IP route configured as:  
192.0.2.1 255.255.255.255 198.51.100.1

Example active/standby configuration using CARP and a failover group

## What You Need

For this configuration, as shown above, you need the following:

- One router
- Two F5<sup>®</sup> LineRate<sup>®</sup> systems with the following:
  - One loopback interface on each
  - One outside interface on each
  - One inside interface on each
- IP addresses for the following:
  - One for the router
  - One for the virtual IP (will also be the IP address for the loopback interface)
  - One for the outside and inside interfaces (one unique IP for each interface)
  - One for each CARP group

## How the Configuration Works

The code example in the next section sets up the following configuration (including some items not shown in the diagram above):

- Each F5<sup>®</sup> LineRate<sup>®</sup> system is configured as follows:
  - Each inside interface (on em2) has a unique IP address (10.1.2.2/24 and 10.1.2.3/24).
  - Each inside interface is part of CARP group 3 with the shared CARP IP set to 10.1.2.1.
    - The standby interface in each CARP group monitors the status of the active interface, making sure the active interface is working.
    - The priority on the active system is set to 2.
    - The priority of the standby system is set to 5.

- Each outside interface (on em1) has a unique IP address (198.51.100.2/24 and 198.51.100.3/24).
- Each outside interface is part of CARP group 1 with the shared CARP IP set to 198.51.100.1.
  - The standby interface in each CARP group monitors the status of the active interface, making sure the active interface is working.
  - The shared CARP IP is used as a next hop gateway address for the router to reach the virtual IP address.
  - The priority on the active system is set to 2.
  - The priority of the standby system is set to 5.
- The virtual IP address is configured as 192.0.2.1 80.
- A loopback interface is configured with the virtual IP as its address (192.0.2.1/32).
- The virtual IP address is attached to a virtual server.
- The real servers are attached to the virtual server.
- The default IP route on each F5<sup>®</sup> LineRate<sup>®</sup> system is set to 0.0.0.0/0 198.51.100.254.
- The router is configured via a static IP route to send requests for destination IP 192.0.2.1 (the VIP) to 198.51.100.1 (the CARP IP).

Requests to the virtual IP 192.0.2.1 are sent to through the router, which sends them to the active system based on its routing and the CARP priority. The active system then sends the requests to the virtual server, to the real server, to the outside interface, then on to the back-end servers. If anything in the path from the active system's em1 interface to the em2 interface fails, the failover group sets both CARP group priorities to 24 (lowest priority and one more than the user-configurable priority range). The standby system will become master for both CARP groups and will accept traffic for 192.0.2.1 (the VIP) using 198.51.100.1 (the CARP IP).

Without the failover group, a failure in the data path (for example em2 fails) would only cause CARP 3 to change from the active system to the standby system. However, the rest of the data path from the router through em1 and lo1 would remain on the originally active system. The traffic would stop at the failed em2 interface. The failover group tells the system to move everything in the data path to the standby system, making it the active system.

The configuration on all F5<sup>®</sup> LineRate<sup>®</sup> systems meant for CARP failover must have the identical configuration, *except* for the following:

- Host name
- Unique management IP
- Unique IP on each CARP interface
- CARP priority

---

## Annotated Configuration

Below is the configuration that is key to configuring active/standby failover group. We have excluded parts of the configuration to focus only on what is required for this configuration to work. In the section below, we have included the complete show run output, which has the complete configuration for a simple load balancer using an active/standby failover group for a data path for both systems.

Configuration for F5<sup>®</sup> LineRate<sup>®</sup> system 1 (active):

| Commands   | Description   |
|--|---|
| <pre>failover group fg1</pre>  | <p>Creates the failover group called fg1.</p>   |
| <pre>interface em1   ip address   198.51.100.2/24   carp 1     priority 2     ip 198.51.100.1    attach failover   group fg1</pre> | <p>Sets the unique IP address for the interface em1.</p> <p>Adds CARP group 1 with a priority of 2 on the em1 interface, making this system the master, and sets the shared CARP IP address.</p> <p>Attaches the failover group called fg1 to CARP group 1.</p> |
| <pre>interface em2   ip address   10.1.2.2/24   carp 3     priority 2     ip 10.1.2.1    attach failover   group fg1</pre>         | <p>Sets the unique IP address for the interface em2.</p> <p>Adds CARP group 3 with a priority of 2 on the em2 interface, making this system the master, and sets the shared CARP IP address.</p> <p>Attaches the failover group called fg1 to CARP group 3.</p> |
| <pre>interface lo1   ip address   192.0.2.1/32</pre>   | <p>Sets the IP address for the loopback interface lo1, which is the same as the virtual IP created below.</p>   |
| <pre>ip route 0.0.0.0/0   198.51.100.254</pre>   | <p>Sets the system's default IP route for all traffic to 198.51.100.254, the router's IP address.</p>   |

|  |  |
|--|--|
| <pre>real-server base   webserver_base  real-server rs1   ip address   10.1.2.101 80   base webserver_base   admin-status online</pre>   | <p>Creates a real server base (base settings omitted for this example) webserver_base.</p> <p>Creates a real server called rs1 based on webserver_base, assigns 10.1.2.101 as the real server's IP address, and brings the real server online.</p> |
| <pre>virtual-ip base   web_base   admin-status online  virtual-ip vip1 ip   192.0.2.1 80 base   web_base</pre>                           | <p>Creates a virtual IP base (base settings omitted for this example) web_base.</p> <p>Creates a virtual IP called vip1 based on web_base, assigns 192.0.2.1 as the virtual IP address, and brings the virtual IP base online.</p>                 |
| <pre>virtual-server vs1   lb-algorithm round-   robin   service http   attach virtual-ip   vip1 default   attach real-server   rs1</pre> | <p>Creates the virtual server vs1 and attaches the virtual IP vip1 and the real server rs1 to it.</p> <p>Also sets the load balancing algorithm and service to HTTP</p>  |

Configuration for F5<sup>®</sup> LineRate<sup>®</sup> system 2 (standby; configuration differences from system 1 shown in blue):

| <b>Commands</b>               | <b>Description</b>                            |
|-------------------------------|---|
| <pre>failover group fg1</pre> | <p>Creates the failover group called fg1.</p> |

|  |  |
|--|--|
| <pre>interface em1   ip address   198.51.100.3/24   carp 1     priority 5     ip 198.51.100.1    attach failover   group fg1</pre>     | <p>Sets the unique IP address for the interface em1.</p> <p>Adds CARP group 1 with a priority of 5 on the em1 interface, making this system the standby, and sets the shared CARP IP address.</p> <p>Attaches the failover group called fg1 to CARP group 1.</p> |
| <pre>interface em2   ip address   10.1.2.3/24   carp 3     priority 5     ip 10.1.2.1    attach failover   group fg1</pre>             | <p>Sets the unique IP address for the interface em2.</p> <p>Adds CARP group 3 with a priority of 5 on the em2 interface, making this system the standby, and sets the shared CARP IP address.</p> <p>Attaches the failover group called fg1 to CARP group 3.</p> |
| <pre>interface lo1   ip address   192.0.2.1/32</pre>   | <p>Sets the IP address for the loopback interface lo1, which is the same as the virtual IP created below.</p>  |
| <pre>ip route 0.0.0.0/0   198.51.100.254</pre>   | <p>Sets the system's default IP route for all traffic to 198.51.100.254, the router's IP address.</p>  |
| <pre>real-server base   webserver_base  real-server rs1   ip address   10.1.2.101 80   base webserver_base   admin-status online</pre> | <p>Creates a real server base (base settings omitted for this example) webserver_base.</p> <p>Creates a real server called rs1 based on webserver_base, assigns 10.1.2.101 as the real server's IP address, and brings the real server online.</p>               |



|  |  |
|--|--|
| <pre> <b>virtual-ip base</b>   <b>web_base</b>   <b>admin-status online</b>  <b>virtual-ip vip1 ip</b>   <b>192.0.2.1 80 base</b>   <b>web_base</b> </pre>             | <p>Creates a virtual IP base (base settings omitted for this example) web_base.</p> <p>Creates a virtual IP called vip1 based on web_base, assigns 192.0.2.1 as the virtual IP address, and brings the virtual IP base online.</p> |
| <pre> <b>virtual-server vs1</b>   <b>lb-algorithm round-robin</b>   <b>service http</b>   <b>attach virtual-ip vip1 default</b>   <b>attach real-server rs1</b> </pre> | <p>Creates the virtual server vs1 and attaches the virtual IP vip1 and the real server rs1 to it.</p> <p>Also sets the load balancing algorithm and service to HTTP</p>  |

---

## Example Show Run Output

The show run output below includes only the sections related to an active/standby CARP configuration.

### Configuration for F5® LineRate® system 1 (active):

```

Building configuration...
!
hostname example-host-a
!
username admin secret encrypted "$2a$04$7TYufYOKVQ8i8bblVtZ1ierxZXzch5mR/
  QeaZH8WnWRzVEkPt0MgS" uid 2000
!
failover group fg1
!
interface em1
 ip address 198.51.100.2 255.255.255.0
 carp 1
  priority 2
  ip 198.51.100.1
  attach failover group fg1
!

```

```

interface em2
  ip address 10.1.2.2 255.255.255.0
  carp 3
    priority 2
    ip 10.1.2.1
    attach failover group fg1
!
interface lol
  ip address 192.0.2.1 255.255.255.255
!
ip route 0.0.0.0/0 198.51.100.254
!
real-server base webserver_web
!
real-server rs1
  ip address 10.1.2.101 80
  base webserver_base
  admin-status online
!
virtual-ip base web_base
  admin-status online
!
virtual-ip vip1 ip 192.0.2.1 80 base web_base
!
virtual-server vs1
  lb-algorithm round-robin
  service http
  attach virtual-ip vip1 default
  attach real-server rs1

```

### **Configuration for F5® LineRate® system 2 (standby):**

Building configuration...

```

!
hostname example-host-b
!
username admin secret encrypted "$2a$04$7TYufYOKVQ8i8bblVtZlierxZXzch5mR/
  QeazH8WnWRzVEkPt0MgS" uid 2000
!
failover group fg1
!
interface em1
  ip address 198.51.100.3 255.255.255.0
  carp 1
    priority 5
    ip 198.51.100.1
    attach failover group 1
!
interface em2
  ip address 10.1.2.2 255.255.255.0
  carp 3
    priority 5
    ip 10.1.2.1
    attach failover group fg1

```

```
!  
interface lol  
  ip address 192.0.2.1 255.255.255.255  
!  
ip route 0.0.0.0/0 198.51.100.254  
!  
real-server base webserver_web  
!  
real-server rs1  
  ip address 10.1.2.101 80  
  base webserver_base  
  admin-status online  
!  
virtual-ip base web_base  
  admin-status online  
!  
virtual-ip vip1 ip 192.0.2.1 80 base web_base  
!  
virtual-server vs1  
  lb-algorithm round-robin  
  service http  
  attach virtual-ip vip1 default  
  attach real-server rs1
```

---

## Forward Proxy Mode Commands

1. [forward-proxy](#)
  1. [admin-status](#)
  2. [attach](#)
  3. [description](#)
  4. [ip](#)
  5. [mode](#)
  6. [service http](#)
    1. [keepalive-timeout](#)
    2. [request-idle-timeout](#)
    3. [response-idle-timeout](#)
    4. [response-timeout](#)
  7. [service tcp](#)
    1. [data-idle-timeout](#)

---

## forward-proxy

Create or modify a forward proxy.

### Use

The F5<sup>®</sup> LineRate<sup>®</sup> forward proxy capability provides a proxy function from one network to another. A common use case for a forward proxy is for connections from your private network to the Internet.

A forward proxy lets you insert custom logic created with scripts. Scripts can perform a variety of functions, including gathering usage statistics, redirecting requests to your own cache, blocking of access to specific sites, managing cookies, and much more.

To use a forward proxy effectively, be sure to create and attach a virtual IP that includes the range of Internet IP addresses you want to go through the forward proxy.



**Caution:** When attaching a virtual IP to a forward proxy, the virtual IP must not include any of the system's own IP addresses. For a virtual IP with a single IP address, do not set the virtual IP's IP address to one of the system's own IP addresses. For a virtual IP with a range of addresses, you must ensure that the IP address range does not contain any of the system's own IP addresses. This may

---

---

mean you need to break the virtual IP into multiple virtual IPs. See [Configuring a range for a virtual IP with forward proxy](#) for more detail and an example.

---

### Default Setting

None

### Command Mode

config

### Syntax

```
[no] forward-proxy <forward_proxy_name>
```

Create or modify a forward proxy

| Parameter          | Type | Description               |
|--------------------|------|---------------------------|
| forward_proxy_name | Word | Name of the forward proxy |

### Related

CLI Reference - [Show Forward Proxy Commands](#)

REST API Reference - [forwardProxy](#)

---

## admin-status

Bring an object, such as a health monitor, real server, or virtual IP, online or offline. After you create an object, you must bring it online.

### Use

You typically set the offline status only when you want to disable the object or block connections to the web server during maintenance or system reconfiguration.

### Default Setting

offline

### Command Mode

config-fproxy

### Syntax

`[no] admin-status offline`

Take the forward proxy out of service

`[no] admin status online`

Put the forward proxy in service

`no admin status`

Remove the configured admin status

---

## attach

### Use

Use to attach an object, such as a virtual IP, to the current forward proxy.

---



**Caution:** When attaching a virtual IP to a forward proxy, the virtual IP must not include any of the system's own IP addresses. For a virtual IP with a single IP address, do not set the virtual IP's IP address to one of the system's own IP addresses. For a virtual IP with a range of addresses, you must ensure that the IP address range does not contain any of the system's own IP addresses. This may mean you need to break the virtual IP into multiple virtual IPs. See [Configuring a range for a virtual IP with forward proxy](#) for more detail and an example.

---



**Note:** Attaching a virtual IP that has an SSL profile attached to a forward proxy is an unsupported configuration. The traffic going out of the proxy with this configuration is unencrypted and will go to the same port the original traffic was destined for. This is either an error or is dangerous, because the client expects the data to be encrypted and it is not.

---

### Default Setting

None

### Command Mode

config-fproxy

### Syntax

`[no] attach virtual-ip <vip>`

Configure one or more virtual IPs that this forward proxy will listen on

| Parameter | Type | Description                    |
|-----------|------|--------------------------------|
| vip       | Word | Name of a virtual IP to attach |

---

## description

Create a description for the forward proxy.

### Use

Use to create a description of the forward proxy use and any other information.

### Default Setting

None

### Command Mode

config-fproxy

### Syntax

`[no] description <desc>`

Description for the forward proxy

`no description`

Remove the description for the forward proxy

| Parameter | Type   | Description  |
|-----------|--------|--|
| desc      | String | Description string. Enter a maximum of 255 characters. |

---

## ip

Configure DSCP settings.

### Use

Use to configure how F5<sup>®</sup> LineRate<sup>®</sup> populates the Differentiated Services Code Point (DSCP) bits as packets pass through to provide quality of service for IP networks. Use the options to configure

where the bits are going to or the specific value to use. For the valid values and more information about DSCP, see [http://en.wikipedia.org/wiki/Differentiated\\_Services\\_Code\\_Point](http://en.wikipedia.org/wiki/Differentiated_Services_Code_Point).

When you enable the copy option, any value that was previously set is changed to 0. Conversely, when you set a value, the copy option is changed to 0, disabling the copy.

### Default Setting

None (system does not do anything with the DSCP bits)

### Command Mode

None

### Syntax

```
[no] ip dscp client <value>
```

Configure IP packet DSCP settings for flows to the client

```
[no] ip dscp client copy
```

Copy IP packet DSCP bits from the server to the client

```
[no] ip dscp server <value>
```

Configure IP packet DSCP settings for flows to the server

```
[no] ip dscp server copy
```

Copy IP packet DSCP bits from the client to the server

| Parameter | Type    | Description   |
|-----------|---------|---|
| value     | Integer | Set IP packet DSCP value for flows to the client or server. |

---

## mode

Specify the forward proxy mode

### Use

Use to configure the forward proxy mode. In release 2.x, the mode is transparent by default and cannot be changed.

### Default Setting

transparent



## Command Mode

config-fproxy

## Syntax

```
[no] mode transparent
```

Proxy using the incoming IP address as the destination (default)

---

## service http

Configure HTTP as the service type for the forward proxy.

## Use

Sets the forward proxy to be an HTTP proxy, operating at layer 7. You must use this service type to enable scripts to interact with HTTP requests and responses.

## Default Setting

Service default is http.

## Command Mode

config-fproxy

## Syntax

```
[no] service http
```

Enable HTTP service

---

## keepalive-timeout

Close the forward proxy TCP connection if there is no HTTP activity in this amount of time.

## Use

If there are no active HTTP transactions (that is, no active requests or responses) to a server for the specified time (in seconds), the system closes the TCP connection to the server, reclaiming resources. This can help avoid problems that some HTTP servers have when connections are kept open indefinitely.

Setting this to a value of 0 disables the timeout, which directs the system not to close server TCP connections due to this timeout.

## Default Setting

0 (disabled)

### Command Mode

config-fproxy-http

### Syntax

```
[no] keepalive-timeout <timeout>
```

Closes the TCP connection if there is no activity in this amount of time

```
no keepalive-timeout
```

Removes the TCP connection timeout

| Parameter | Type | Description                           |
|-----------|------|---------------------------------------|
| timeout   | Real | Number of seconds (can be fractional) |

---

## request-idle-timeout

Configure the number of seconds to wait to receive any part of a request before closing the connection.

### Use

The system closes the connection if it takes longer than the specified time (in seconds) to receive any part of the request from the client.

Consider the size of a typical client request as well as the user environment to set this value. For example, an application where users upload photos or HD videos using mobile devices would need a longer timeout than simple web pages due to mobile bandwidth and device processing limitations.

### Default Setting

0 (disabled)

### Command Mode

config-fproxy-http

### Syntax

```
[no] request-idle-timeout <timeout>
```

Number of seconds to wait for new request data before closing the connection

`no request-idle-timeout`

Remove the request idle timeout

| Parameter | Type | Description                           |
|-----------|------|---------------------------------------|
| timeout   | Real | Number of seconds (can be fractional) |

---

## response-idle-timeout

Configure the number of seconds to wait for new response data before closing the connection.

### Use

The system closes the connection if, after transmitting the request to the server, it takes longer than the specified time (in seconds) either to receive any part of the response from the HTTP server or to transmit any part of the response to the client.

Consider the size of a typical response for your application as well as the user environment to set this value. For example, an application where users download HD videos using mobile devices would need a longer timeout than simple web pages due to mobile bandwidth and device processing limitations.

### Default Setting

0 (disabled)

### Command Mode

config-fproxy-http

### Syntax

`[no] response-idle-timeout <timeout>`

Number of seconds to wait for new response data before closing the connection

`no response-idle-timeout`

Removes the response idle timeout

| Parameter | Type | Description                           |
|-----------|------|---------------------------------------|
| timeout   | Real | Number of seconds (can be fractional) |

---

## response-timeout

Configure the number of seconds to wait for the server to respond to a request.

### Use

The system sends an HTTP 504 error response to the client and closes the connection if the HTTP server takes longer than the specified time (in seconds) to respond to a request.

Consider the amount of time the web server takes to respond to any request. The response-timeout must always be configured to be higher than the amount of time it takes for any of the web servers to respond to a request.

### Default Setting

0 (disabled)

### Command Mode

config-fproxy-http

### Syntax

```
[no] response-timeout <timeout>
```

Number of seconds to wait for the server to respond to a request

```
no response-timeout
```

Removes the response timeout

| Parameter | Type | Description                           |
|-----------|------|---------------------------------------|
| timeout   | Real | Number of seconds (can be fractional) |

---

## service tcp

Configure TCP as the service type for the forward proxy. The system does load balancing of TCP connections without processing the TCP payload.

### Use

Sets the forward proxy to be a TCP proxy, operating at layer 4. Use this service type for non-HTTP protocols, such as SMTP email, or if you do not want the F5<sup>®</sup> LineRate<sup>®</sup> to interact with HTTP requests and responses. Use this service type to forward HTTPS traffic from the clients to the back-end servers. In this case, only attach a virtual IP that does not have an SSL profile attached to it.

### Default Setting

Service default is http.

**Command Mode**

config-fproxy

**Syntax**

[no] service tcp

Sets the service type to TCP

**data-idle-timeout**

**Use**

The system closes the TCP connection if there is no activity in this amount of time.

**Default Setting**

0 (disabled)

**Command Mode**

config-fproxy-tcp

**Syntax**

[no] data-idle-timeout <timeout>

Closes the TCP connection if there is no activity in this amount of time

no data-idle-timeout

Removes the data idle timeout

| Parameter | Type | Description                           |
|-----------|------|---------------------------------------|
| timeout   | Real | Number of seconds (can be fractional) |

---

## Health Monitor Mode Commands

1. [health-monitor](#)
  1. [admin-status](#)
  2. [attach](#)
  3. [description](#)
  4. [interval](#)
  5. [invert](#)
  6. [logging](#)
  7. [override-ip](#)
  8. [override-port](#)
  9. [server-down](#)
  10. [server-up](#)
  11. [timeout](#)
  12. [type tcp](#)
  13. [type http](#)
    1. [request-body](#)
    2. [request-header](#)
    3. [request-method](#)
    4. [request-target](#)
    5. [request-version](#)
    6. [response-body](#)
    7. [response-header](#)
    8. [response-no-header](#)
    9. [response-status](#)
    10. [response-version](#)

Use the following commands to configure health monitors.

---

### health-monitor

Configures a health monitor

#### Use

Use to create a health monitor to regularly check that servers are up and able to accept connections or respond to requests. You can attach a health monitor to a real server and to a real server base.

For HTTP health monitors, you can configure the type of requests and responses.

## Default Setting

None

## Command Mode

configure

## Syntax

```
[no] health-monitor <name>
```

Configures a health monitor

| Parameter | Type | Description                |
|-----------|------|----------------------------|
| name      | Word | Name of the health monitor |

## Related Commands

CLI Reference - [Real Server Mode Commands](#)

REST API Reference - [monitor](#)

---

## admin-status

Bring an object, such as a health monitor, real server, or virtual IP, online or offline. After you create an object, you must bring it online.

### Use

You typically set the offline status only when you want to disable the object or block connections to the web server during maintenance or system reconfiguration.

## Default Setting

offline

## Command Mode

config

## Syntax

```
admin-status offline
```

Bring the object offline

`admin-status online`

Bring the object online

`no admin-status`

Remove the directly configured admin status

---

## attach

Attach an object, such as an SSL profile, to this health monitor

### Use

Use to attach an SSL profile to the health monitor to override the real server's settings.

When you attach the health monitor to a real server, the health monitor uses the IP address and port from the real server to access the web server. If the real server uses SSL, the health monitor automatically uses the same SSL profile.

If you want the health monitor to use a different SSL configuration to connect to the web server, you can create and attach a different SSL profile to the health monitor. This SSL profile overrides the SSL profile attached to the real server and tells the health monitor to use this SSL profile.

If the real server uses SSL, but you want to health monitor to connect without using SSL, do one of the following to override the real server's SSL profile and tell the health monitor to connect using HTTP, not HTTPS:

- CLI—Use the none form of the command.
- REST—Set the config/app/health/monitor/<name>/sslProfile node to an empty string.

### Default Setting

None

### Command Mode

config-hmonitor

### Syntax

```
[no] attach ssl profile <name>
```

Attach or replace the SSL profile for this health monitor. If no profile is set on the health monitor, the SSL profile is obtained from each real server being monitored.

```
[no] attach ssl profile none
```



Set this health monitor to do non-SSL HTTP. Overrides the SSL profile set on each real server being monitored.

| Parameter | Type | Description                        |
|-----------|------|------------------------------------|
| name      | Word | Name of the SSL profile to attach. |

### Related Commands

[Real Server Mode Commands](#)

[SSL Mode Commands](#)

---

## description

Description for the health monitor.

### Use

Use to create a description of the health monitor use and any other information.

### Default Setting

None

### Command Mode

config-hmonitor

### Syntax

```
[no] description <desc>
```

Description for health monitor

```
no description
```

Removes the description

| Parameter | Type   | Description  |
|-----------|--------|--|
| desc      | String | Description string. Enter a maximum of 255 characters. |

---

## interval

Time to wait between health monitor probes.

### Use

Use to set how often the health monitor probes the server. In setting the interval, consider how the interval affects both the server and F5<sup>®</sup> LineRate<sup>®</sup>. You do not want the health monitor probes to overwhelm either system by being too frequent or to not detect a problem with a server by being too infrequent.

### Default Setting

10

### Command Mode

config-hmonitor

### Syntax

`[no] interval <intvl>`

Time to wait between monitor probes

`no interval`

Removes the configured time to wait between monitor probes

| Parameter | Type | Description                            |
|-----------|------|--|
| intvl     | Real | Number of seconds (can be fractional). |

---

## invert

Reverse the success criteria, that is, mark the real server as down if the configured response criteria are met.

### Use

Use to reverse the success criteria for the health monitor. When using invert, the health monitor marks the real server as down if the configured response is received. If a response other than the configured response is received, then the real server is marked as up.

One use case for invert is to support steering of traffic to a service that is in an active-standby configuration. You configure the health monitors such that when the active real server is functioning, it is marked a up, and the backup real server is marked as down. If the active real server is not functioning and the backup is functioning, the backup is marked as up. If both are not functioning, then both of them are marked as down.

Below is an example configuration:

- Real server rs1 is the primary, and real server rs2 is the secondary.
- Health monitor hm1 is attached to rs1 and monitors rs1's IP address.
- Health monitor hm2 is attached to rs2 and monitors rs2's IP address.
- Health monitor hm3 is attached to rs2 and monitors rs1's IP address. hm3 has the same settings as hm1 (same values for interval, server-up, etc.), but it also has the invert option set.
- If rs1 goes down, the system reports that rs1 is down and rs2 is up, making rs2 the active, and rs1 the standby.

## Default Setting

None

## Command Mode

config-hmonitor

## Syntax

[no] **invert**

Marks the real server as down when the expected response is received

---

## logging

Configure logging level.

## Use

Use for debugging to log information about health monitor probes. Debugging on multiple health monitors will affect system performance. Normally, you do not need to use logging.

## Parameters

| Parameter | Description           |
|-----------|-----------------------|
| 0         | Almost no logging     |
| 1         | 0 + Failed probe logs |
| 2         | 1 + Passed probe logs |



NOTE: A log level greater than 2 is treated as level 2.

---

## Default Setting

Disabled

## Command Mode

config-hmonitor

## Syntax

`[no] logging detailed`

Enable detailed logging (sets to most verbose) for debugging when instructed to set by technical support personnel

`[no] logging detailed <level>`

Enable detailed logging (level indicates verbosity)

[healthMonitor](#)

---

## override-ip

Configure an IP address to use for monitoring.

## Use

Use to configure an IP address to use for monitoring instead of using the IP address configured on the real server.

When you attach the health monitor to a real server, the health monitor uses the IP address and port from the real server to access the web server. If you want the health monitor to use a different IP address, you can override the IP address.

## Default Setting

None

### Command Mode

config-hmonitor

### Syntax

```
[no] override-ip <ip_address>
```

Configure an IP address to use for monitoring instead of using the IP address configured on the real server

**no override-ip**

Remove the configured IP address to use for monitoring instead of using the IP address configured on the real server

| Parameter  | Type   | Description   |
|------------|--------|---|
| IP_address | IPAddr | IP address to use instead of the IP address on the real server. |

---

## override-port

Configure a port to use for monitoring.

### Use

Use to configure a port to use for monitoring instead of using the port configured on the real server.

When you attach the health monitor to a real server, the health monitor uses the IP address and port from the real server to access the web server. If you want the health monitor to use a different port, you can override the port.

### Default Setting

None

### Command Mode

config-hmonitor

### Syntax

`[no] override-port <port>`

Configure a port to use for monitoring instead of using the port configured on the real server

`no override-port`

Remove the port to use for monitoring instead of using the port configured on the real server

| Parameter | Type    | Description                                     |
|-----------|---------|---|
| port      | Integer | Port to use instead of the port on real server. |

---

## server-down

Criteria to move a server from up to down.

### Use

Use to determine when a server that is up should be marked as down, because the specified number of health probes has failed. The ratio you enter should take into account network and other transient conditions that may cause health probes to fail, but which you want to disregard.

For example, if you enter 8/10, this sets the threshold for marking the server as down to the failure of 8 out of the last 10 health probes. If the health probe fails 8 out of the last 10 times, the system takes the server offline.

When the system takes a server offline, the system no longer sends traffic to that server.

### Default Setting

1/10 (any single probe failure will mark the server as down)

### Command Mode

config-hmonitor

### Syntax

`[no] server-down <frac>`

Criteria to move server from up to down

`no server-down`

Remove the configured criteria to move server from up to down

| Parameter | Type   | Description  |
|-----------|--------|--|
| frac      | String | Enter the ratio of failed to total probes (m/n where m of the last n health probes must fail). |

## Related Commands

[server-up](#)

---

## server-up

Criteria to move a server from down to up.

### Use

Use to determine when a server that is down should be marked as up because the specified number of health probes has succeeded. The ratio you enter should take into account network conditions and other transient conditions that may cause health probes to fail, but which you wish to disregard.

For example, if you enter 9/10, this sets the threshold for marking the server up to the success of 9 out the last 10 health probes. If the health probe succeeds 9 out of the last 10 times, the system puts the server back online.

When the system takes a server offline, the system no longer sends traffic that server. When the server comes back online, the system starts to send traffic to the server.

### Default Setting

2/2

### Command Mode

config-hmonitor

### Syntax

```
[no] server-up <frac>
```

Criteria to move server from down to up

```
no server-up
```

Remove the configured criteria to move server from down to up

| Parameter | Type   | Description   |
|-----------|--------|---|
| frac      | String | Enter the ratio of successful to total probes (m/n where m of the last n health probes must succeed). |

## Related Commands

[server-down](#)

---

## timeout

Time (in seconds) to wait before considering a probe as failed.

### Use

Use to set how long the system waits to determine if a specific health probe has failed. The health monitor will determine an individual health probe to fail if it does not respond within this time.

One use of this setting is to test the server's response time.

### Default Setting

3

### Command Mode

config-hmonitor

### Syntax

`[no] timeout <intvl>`

Time to wait before considering a probe as failed

`no timeout`

Remove the configured time to wait before considering a probe as failed

| Parameter | Type | Description                           |
|-----------|------|---------------------------------------|
| intvl     | Real | Number of seconds (can be fractional) |



---

## type tcp

Set type of health monitor to TCP.

### Use

Use this type for servers that are not using HTTP, for example, an email server. The health monitor establishes a TCP connection. If the connection is successful, the health probe is successful.

### Default Setting

None

### Command Mode

config-hmonitor

### Syntax

`[no] type tcp`

Set as TCP health monitor

`no type`

Remove the health monitor type

---

## type http

Set type of health monitor to HTTP.

### Use

Use this for web servers that are using HTTP. This type must match the service setting on any real sever to which the health monitor is attached. Use for HTTPS as well.

The health monitor sends HTTP requests. You can configure the request body, header, method, version, and status. You can also specify the response header, body, status, and version.

### Default Setting

Head request

### Command Mode

config-hmonitor

## Syntax

`[no] type http`

Set as HTTP health monitor and enter HTTP options mode

`no type`

Remove the health monitor type

---

## request-body

Configure data to be included as body of request.

### Use

Use to specify the data for the request body.

### Default Setting

None

### Command Mode

http

### Syntax

`[no] request-body <body>`

Data to be included as body of request

`no request-body`

Removes the data to be included as body of request

| Parameter | Type      | Description  |
|-----------|-----------|--|
| body      | EscString | Body content as a string that can contain simple escaped characters like <code>\"</code> , <code>\r</code> , <code>\n</code> , <code>\t</code> . |

---

## request-header

Configure additional HTTP headers to include in the HTTP request.

### Use

Use to specify one or more headers to include in the HTTP request. Specify in the format:  
header type: header\_name=value

You might use this to tell the web server that the request is coming from a health monitor or to ensure the server will respond to the request.

### Default Setting

None

### Command Mode

http

### Syntax

```
[no] request-header <header_value>
```

Additional HTTP header to include in the HTTP request

| Parameter    | Type   | Description  |
|--------------|--------|--|
| header_value | String | Header and value as a string (for example, "Cookie: foo=bar; id=me") |

---

## request-method

Configure HTTP request method or verb indicating action to perform.

### Use

Use to set the HTTP request method you want to use. The available methods are: GET, HEAD, POST, TRACE, OPTIONS, DELETE, and CONNECT.

### Default Setting

HEAD

### Command Mode

http

### Syntax

```
[no] request-method <method>
```

HTTP request method or verb indicating action to perform

```
no request-method
```

Remove the configured HTTP request method or verb indicating action to perform

| Parameter | Type | Description                                    |
|-----------|------|--|
| method    | Word | Request method (for example, GET, POST, HEAD). |

---

## request-target

Configure URL relative to the root of real server, (for example "/health.html").

### Use

Use to specify an absolute or relative URL that points to where the health monitor should look for a file.

### Default Setting

/

### Command Mode

http

### Syntax

```
[no] request-target <target>
```

URL relative to the root of real-server, (for example, "/health.html")

```
no request-target
```

Remove the configured URL relative to the root of real-server

| Parameter | Type   | Description            |
|-----------|--------|------------------------|
| target    | String | Request target string. |

---

## request-version

Configure HTTP protocol version included in HTTP header.

### Use

Use to specify the HTTP protocol version that the health monitor uses for requests. For example, "HTTP/1.1"

### Default Setting

None

## Command Mode

http

## Syntax

```
[no] request-version <version>
```

HTTP protocol version included in HTTP header

```
no request-version
```

Remove the configured HTTP protocol version included in HTTP header

| Parameter | Type   | Description                                 |
|-----------|--------|---|
| version   | String | Version as string (for example, "HTTP/1.1") |

---

## response-body

Configure the expected response body.

## Use

Use if you want to specify the expected response body. You can specify response body one of the following ways:

- Exact match—Match the exact content of the entire response body. For the response to be successful, the body must exactly match what you specify here. In the CLI, the maximum length of the body match is 10,240 characters.
- Regex match—Match the regex somewhere in the response body. Use Perl-compatible syntax.
  - We recommend checking the regex before implementing it. One common tool is the [pcretest tool](#), which is available from bash mode in F5<sup>®</sup> LineRate<sup>®</sup>.
  - Be aware that a complex regex or one that has to search for text at the end of a long page could affect performance.

In the CLI, configuring one method automatically removes any configuration from the other method.

In REST, if the deprecated node (/config/app/health/monitor/<name>/httpOptions/response/body) is currently configured, you must send a DELETE command for the deprecated node before using this node.

## Default Setting

None

## Command Mode

http

## Syntax

**response-body** <body>

String to match against the response body (exact match)

**response-body regex** <body>

Regex string to match against the response body

**no response-body**

Removes the configured response body

[no] **response-body-max-length** <max>

Maximum number of bytes of the response body to be checked for a match. This applies to both exact matches and regex matches.

| Parameter | Type      | Description   |
|-----------|-----------|---|
| body      | EscString | Expected response body as a string.   |
| max       | Integer   | Maximum number of bytes of the response body to be checked for a match. This applies to both exact matches and regex matches. |

---

## response-header

Configure a specific header/value pair for the response.

## Use

Use if you want to specify the exact content of a response header and value pair. For the response to be successful, the header must exactly match what you specify here.

## Default Setting

None

## Command Mode

http

## Syntax

`[no] response-header`

Require response to have a particular header/value pair

| Parameter | Type   | Description   |
|-----------|--------|---|
| header    | String | Header as a string (for example, "Content-type: text/html") |

---

## response-no-header

Configure the response to not have a specific header.

### Use

Use if you want to specify content that the response header must not contain. For the response to be successful, the header must not contain what you specify here.

### Default Setting

None

### Command Mode

http

### Syntax

`[no] response-no-header`

Require response to not have a particular header

| Parameter | Type   | Description  |
|-----------|--------|--|
| header    | String | Header name as a string (for example, "Content-length"). |

---

## response-status

Expected HTTP response status code indicating the outcome of the request.

### Use

Use if you want to specify the exact content of a HTTP response status code. For the response to be successful, the status code must exactly match what you specify here.

### Default Setting

200 OK

## Command Mode

http

## Syntax

`[no] response-status <target>`

Expected HTTP response status code indicating the outcome of the request

`no response-status`

Removes the configured expected HTTP response status code

| Parameter | Type    | Description   |
|-----------|---------|---|
| status    | Integer | HTTP status code (for example., "200" for "200 OK") |

---

## response-version

Configure the expected HTTP protocol response version included in HTTP header.

## Use

Use if you want to specify the exact HTTP response version. For the response to be successful, the version must exactly match what you specify here. For example, "HTTP/1.1"

## Default Setting

None

## Command Mode

http

## Syntax

`[no] response-version <version>`

Expected HTTP protocol response version included in the HTTP header

`no response-version`

Removes the configured expected HTTP protocol response version included in the HTTP header

| Parameter | Type | Description |
|-----------|------|-------------|
|-----------|------|-------------|



|         |        |   |
|---------|--------|---|
| version | String | HTTP Version as string (for example, "HTTP/1.0"). |
|---------|--------|---|

---

## Host Name Mode Commands

---

### hostname

#### Use

Use to set the host name for the system. The host name changes the system prompt and the system logs.

The naming rules for a host name are:

- Must not be longer than 63 characters
- Must start with letter
- Must end with letter or digit
- Can use only letters, digits, hyphens, and periods
- Quotation marks can optionally be added.

#### Default Setting

LROS

#### Command Mode

configure

#### Syntax

`hostname <name>`

Set the host name for the device

| Parameter | Type   | Description        |
|-----------|--------|--------------------|
| name      | String | Name of the system |

#### Related

REST API Reference - [hostname](#)

---

## Interface Mode Commands

1. [interface](#)
  1. [carp](#)
    1. [advert-base](#)
    2. [attach](#)
    3. [authentication](#)
    4. [description](#)
    5. [down-threshold](#)
    6. [ip](#)
    7. [ipv6](#)
    8. [priority](#)
    9. [shutdown](#)
  2. [channel-group](#)
  3. [description](#)
  4. [encapsulation](#)
  5. [flowcontrol receive](#)
  6. [flowcontrol send](#)
  7. [ip address](#)
  8. [ip address dhcp](#)
  9. [ipv6 address](#)
10. [mtu](#)
11. [shutdown](#)

Use the following commands to configure interfaces.

---

## interface

Configure settings for a network interface for management or data use.

### Use

Typically, you want to configure one interface for management use and one or more other interfaces for data use.

To see the names of your interfaces, use the following:

- CLI command: **show interfaces**

- The following information displays:
  - A list of all interfaces on the system displays. It is possible for the system to have an interface that F5<sup>®</sup> LineRate<sup>®</sup> cannot detect.
  - The first line is the interface name and its status. The interface name is based on the driver for the interface type. The remaining lines list the information available about the interface (typically, manufacturer, model, MAC address, speed in kilobits, and more).
  - Below are the names used for some common interfaces:
    - em—Intel 1Gb interface
    - igb—Intel 1Gb interface
    - bce—Broadcom 1Gb interface
    - ix—Intel 10 Gb interface
    - oce—Emulex 10 Gb interface
    - xn—Xen netfront interface (used by Amazon EC2)
    - lo—Loopback interface (internal interface)
    - po—Port channel interface
- REST API node: /status/system/interface?op=list
  - The names and current settings for every interface display. You can find all of the information that is included in the show interfaces command in the hierarchy below /status/system/interface.

You can create up to 4094 subinterfaces on an interface. Subinterfaces are disabled by default when you create them. Use the [encapsulation](#) command to set up trunked ports for VLANs.

## Default Settings

interface—enabled

port channel—enabled

subinterface—disabled

## Command Mode

config

## Syntax

```
[no] interface <interface_name>
```

Configure an interface

```
[no] interface <interface_name>.<n>
```

Create or configure a subinterface. Use a subinterface to set up trunked ports for VLANs.

```
[no] interface port-channel <chan_num>
```

Configure a port channel

| Parameter      | Type    | Description  |
|----------------|---------|--|
| chan_num       | Integer | Port channel number, which you can specify as just the number or as po<n>. You must use po<n> when you configure the port channel.>  |
| interface_name | String  | Name of an interface. Interface name may be one of the following: \n physical interface (for example, ix0), a port channel (for example, po0), or subinterface (for example ix0.1, po0.1). |

## Related Commands

[carp](#)

[encapsulation](#)

REST API Reference - [interface](#)

---

## carp

Set up CARP redundancy protocol.

### Use

Use CARP to provide high availability and permit the system to fail over from one host to another. In F5<sup>®</sup> LineRate<sup>®</sup>, you configure CARP on each interface that you want in a group using the same Virtual Host ID (VHID). The Ethernet segment must support Ethernet and IP multicast. You can configure multiple CARP groups on an interface.

### *CARP Group Setup*

Each CARP group must have a unique VHID on a particular VLAN and must not be the same as a VRRP VHID on the same VLAN. The system uses 241 as the IP protocol number.

Each CARP group can be master on only one system at a time. If you only want one system to be master and accept traffic at a time (active/passive deployment), you only need one CARP group, which is a single VHID. However, if you want to create an active/active deployment, you need the same number of CARP groups (VHIDs) as the number of systems that you would like to be active. For example, if you want to create a cluster of 5 instances where 3 systems are active and 2 are passive, you need 3 CARP groups.

The interface with the lowest priority value in the group becomes the master. Every interface in a group should have a unique priority within the group. The master does not advertise until the IP addresses are configured for the group.



**Best Practice:** We recommend leaving gaps in the carp priority numbering, so you can insert new systems into the priority ordering. In particular, do not configure any system to have priority 1 so that at a later time, any system's priority can be set to 1 to manually have that system take over the master role.

---

The master replies to ARP requests for the group's IP addresses using the group's unique MAC address. The group MAC address uses the same formula as the VRRP MAC address (00-00-5E-00-01-x) with the last octet set to the group's VHID.

If using a password, all members of the group must have the same password, and only interfaces with the same password and group ID can be part of the group.

#### *CARP Failover*

The system supports subsecond failover, because advertisements are subsecond. The backup interface does not fail over until it misses seeing three (default) advertisements from the master. This takes into account dropped advertisement packets on congested networks and avoids unnecessary failovers.

When a backup believes that the master has failed, the backup sends out a gratuitous ARP reply to identify that the backup is now master for the IP address and group MAC address. The backup then responds to ARP requests for the IP address.

Use shutdown to test failover by shutting down the master. You can also use shutdown to keep the CARP configuration, when you want to shut down CARP on the interface to force a failover while reconfiguring CARP.

#### *Direct-attach vs. Gateway Mode*

If you're using virtual IPs in direct-attach mode (configuring the virtual IP in the CARP group), put the virtual IP in the CARP group. You do not configure it on the interface, but only in the CARP group. From a network topology point of view, any IP configured in CARP is like it is configured on the interface, meaning that the system will ARP for that IP address on that interface.

If you are using gateway mode (configuring the gateway address in the CARP group), put the gateway IP in the CARP group, not the virtual IP.

#### *Port Channels*

For a port channel:

- Before adding an interface to a port channel, you must remove it from the CARP group.
- You can configure CARP on a port channel.

For CARP examples, see [CARP Example - Active/Standby](#) and [CARP Example - Active/Active](#).



**Note:** For Amazon EC2 instances, EC2 networking does not support CARP.

---



**Note:** If you installed using VMWare, you must configure your vSwitches and hosts to permit CARP. See [Configuring vSwitches and Hosts to Permit CARP and Failover](#).

---

### Default Setting

None

### Command Mode

config

### Syntax

```
carp <vhid>
```

Set the CARP group ID on this interface

```
no carp <vhid>
```

Remove all configuration for CARP group ID on this interface

| Parameter | Type    | Description  |
|-----------|---------|--|
| vhid      | Integer | Virtual Host ID (VHID) used to identify the CARP group. The value must be unique on the Ethernet segment and must not be the same as a VRRP VHID on the same Ethernet segment. Valid values are 1 - 254. |

---

## advert-base

### Use

Use to set the base time interval for CARP advertisements in milliseconds. CARP advertisements are sent based on this interval plus an offset determined by the priority.

Advertising interval in milliseconds = advert-base + (priority \* 4).

The default advert-base is 100 ms. We do not recommend changing the base time interval.

### Default Setting

100 ms

### Command Mode

config

### Syntax

```
[no] advert-base <base_time>
```

Set the base time interval for CARP advertisements.

```
no advert-base
```

Remove the base time interval for CARP advertisements.

| Parameter | Type    | Description  |
|-----------|---------|--|
| base_time | Integer | Base time interval for CARP advertisements in milliseconds |

---

## attach

### Use

Use to attach a failover group to the CARP interface. The failover group works with the CARP settings for high availability of the interfaces. For more information, see one of the following:

- CLI Reference - [Failover Mode Commands](#).
- REST API Reference - [failover](#)

### Default Setting

None

### Command Mode

config

### Syntax



`[no] attach <failover_grp>`

Attach the specified failover group to this interface.

`no attach`

Remove the attached failover group from this interface.

| Parameter  | Type | Description                |
|------------|------|----------------------------|
| group_name | Word | Name of the failover group |

---

## authentication

### Use

Use to set the string to generate the authentication key. All systems participating in the CARP group must have the same password.

### Default Setting

None

### Command Mode

config

### Syntax

`[no] authentication <pass>`

Set authentication password for the CARP group.

`no authentication`

Remove the authentication password for the CARP group

| Parameter | Type   | Description          |
|-----------|--------|----------------------|
| pass      | String | CARP group password. |

---

## description

Create a description for the interface.

## Use

Use to create a description of the interface type, use, and any other information to identify the interface. Enter a maximum of 255 characters.

## Default Setting

None

## Command Mode

config

## Syntax

```
[no] description <desc>
```

Description for this CARP group

```
no description
```

Remove the description for this CARP group

| Parameter | Type   | Description                     |
|-----------|--------|---------------------------------|
| desc      | String | Description of this CARP group. |

---

## down-threshold

### Use

Use to set the threshold for detecting that the CARP master is down. Number of expected CARP advertisement packets that must be lost before the master is declared down, and the next lowest priority interface becomes master. Default is 3.

### Default Setting

3

### Command Mode

config

### Syntax

```
[no] down-threshold <thresh>
```

Set threshold for detecting that the CARP master is down.

```
no down-threshhold
```

Remove the threshold for detecting that the CARP master is down.

| Parameter | Type    | Description      |
|-----------|---------|------------------|
| thresh    | Integer | Threshold value. |

---

## ip

### Use

Use to configure the IPv4 address for the CARP group. This is the address for which this VHID will manage failover.

### Default Setting

None

### Command Mode

config

### Syntax

```
[no] ip <addr>
```

IPv4 address for which this VHID will manage failover

| Parameter | Type   | Description  |
|-----------|--------|--|
| addr      | IPAddr | IPv4 address for the CARP group. See <a href="#">IP Address Notation</a> . |

---

## ipv6

### Use

Use to configure the IPv6 address for the CARP group. This is the address for which this VHID will manage failover.

For IPv6, the physical interface must have an IPv6 address and the CARP IP address must be within the subnet of the physical interface's IPv6 address.

### Default Setting

None

### Command Mode

config

### Syntax

```
[no] ipv6 <addr>
```

IPv4 address for which this VHID will manage failover

| Parameter | Type   | Description  |
|-----------|--------|--|
| addr      | IPAddr | IPv6 address for the CARP group. See <a href="#">IP Address Notation</a> . |

---

## priority

### Use

Use to set the CARP priority, also known as advskew, for this interface. The lowest priority interface in a group is the master. Valid user-configurable values are 1 - 23.

### Default Setting

1

### Command Mode

config

### Syntax

```
[no] priority <priority>
```

Set the CARP priority, also known as advskew.

```
no priority
```

Remove the CARP priority, also known as advskew.

| Parameter | Type    | Description                       |
|-----------|---------|-----------------------------------|
| priority  | Integer | CARP priority for this interface. |

---

## shutdown

### Use

Stops this system from participating in the CARP group, but does not remove the CARP group configuration.

### Default Setting

None

### Command Mode

config

### Syntax

`[no] shutdown`

Stops this system from participating in the CARP group.

---

## channel-group

### Use

Use to add this interface to a port channel group.

You can create port channel groups to aggregate two to eight interfaces for increased throughput. An interface can be a member of only one port channel.

Port channels generally act like any other interface, and you can configure most settings on them. For example, you configure a VLAN on the port channel, not on the member interfaces. The table below describes the effect of settings on the physical interface before adding it to a port channel, and the settings you can configure on a port channel.

| Interface setting | Effect when configured on physical interface before adding to port channel              | Effect when configured on port channel interface           | Notes   |
|-------------------|---|--|---|
| carp              | Not valid. You must remove CARP before adding the interface to a port channel.          | Valid.   |   |
| channel-group     | Valid.  | Not valid. You cannot nest channel groups (port channels). |   |
| description       | Valid.  | Valid.   |   |
| encapsulation     | Not valid. You must remove encapsulation before adding the interface to a port channel. | Valid.   |   |
| flowcontrol       | Valid. Remains in effect after adding to a port channel.                                | Not valid.   |   |
| ip                | Ignored. IP address remains on interface, but has no effect.                            | Valid.   | When you remove the interface from the port channel, the IP address will be active. |
| ipv6              | Ignored. IP address remains on interface, but has no effect.                            | Valid.   | When you remove the interface from the port channel, the IP address will be active. |
| mtu               | Ignored. The MTU remains on interface, but has no effect.                               | Valid.   | When you remove the interface from the port channel, the MTU will be active.        |

The mode setting on each port channel member interface must be set the same.

Port channels in F5<sup>®</sup> LineRate<sup>®</sup> have two possible modes:

- Active—Sends out LACP probing packets to the switch. The switch can be set to active or passive LACP. If one interface fails, the switch will use the remaining interfaces configured for the port channel. Whenever the port channel configuration changes, the port channel and the switch negotiate the settings. The port channel is not active during the negotiation period.
- On (static)—Switch must be configured the same way. If one interface in the port channel fails, the whole port channel fails.

### Default Setting

None

## Command Mode

config-int

## Syntax

```
[no] channel-group <chan_num> mode active <chan_num>
```

Select LACP in active mode

```
[no] channel-group <chan_num> mode on <chan_num>
```

Select static link aggregation

```
no channel-group
```

Remove the configured interface from the channel group

| Parameter | Type    | Description   |
|-----------|---------|---|
| chan_num  | Integer | Port channel number, which you can specify as just the number (<chan_num>) or as po<chan_num>. You must use po<chan_num> when you configure the port channel. |

---

## description

Create a description for the interface.

## Use

Use to create a description of the interface type, use, and any other information to identify the interface. Enter a maximum of 255 characters.

## Default Setting

No description

## Command Mode

config

## Syntax

```
description <desc>
```

Description for the interface

`no description`

Remove the description

| Parameter | Type   | Description  |
|-----------|--------|--|
| desc      | String | Description string. Enter a maximum of 255 characters. |

---

## encapsulation

Set the encapsulation type for a subinterface.

### Use

You can only set the encapsulation type for subinterfaces. Use subinterfaces and encapsulation for VLANs to create a trunked port (also called a tagged port). The system encapsulates the packets using the specified protocol and VLAN tag.

To set the encapsulation, which uses the IEEE 802.1Q standard, you must know the switch tag for the VLAN you are configuring.

For a port channel:

- Before adding an interface to a port channel, you must remove encapsulation.
- You can configure encapsulation on a port channel.

### Default Setting

No encapsulation

### Command Mode

config

### Syntax

```
[no] encapsulation dot1q <tag>
```

IEEE 802.1Q virtual LAN encapsulation

```
no encapsulation
```

Remove the configured encapsulation



| Parameter | Type    | Description                                       |
|-----------|---------|---|
| tag       | Integer | VLAN tag used on the switch. Valid range: 1-4094. |

## Related Commands

[interface](#)

---

## flowcontrol receive

Ethernet flow control receive operation.

### Use

Generally, we recommend leaving flow control off for both receive and send, unless you have a specific reason to turn it on.

Turning on flowcontrol receive tells the port to honor the pause frame from a sending interface. Leaving flow control off tells the interface to ignore the pause frame from the sending interface.



**Note:** The system supports flow control only on ix interfaces. Flow control is off by default on ix interface types. For other interfaces, the default varies based on the interface type.



**Caution:** Turning on flowcontrol receive could stop all traffic on the interface.

---

For a port channel:

- Any flow control setting configured on an interface remains in effect when you add the interface to a port channel.
- You cannot configure flow control on a port channel.

### Default Setting

Depends on interface type. See Note above.

### Command Mode

config

### Syntax

```
flowcontrol receive off
```

Always ignore pause frames received

```
flowcontrol receive on
```

Always respond to pause frames received

```
no flowcontrol receive
```

Remove the configured flowcontrol receive

---

## flowcontrol send

### Use

Generally, we recommend leaving flow control off for both receive and send, unless you have a specific reason to turn it on.

Turning flow control on tells the interface to send the pause frame when the interface is overloaded. Leaving flow control off tells the interface to not to send the pause frame when the interface is overloaded.

---



**Note:** The system supports flow control only on ix interfaces. Flow control is off by default on ix interface types. For other interfaces, the default varies based on the interface type.

---

For a port channel:

- Any flow control setting configured on an interface remains in effect when you add the interface to a port channel.
- You cannot configure flow control on a port channel.

### Default Setting

Depends on interface type. See Note above.

### Command Mode

```
config
```

### Syntax

```
flowcontrol send off
```

Never send pause frames for flow control

```
flowcontrol send on
```

Enable sending of pause frames for flow control

`no flowcontrol send`

Remove the configured flowcontrol send

---

## ip address

Set IPv4 address for the interface.

### Use

You can configure more than one IP address on an interface. Each virtual IP must also be assigned to an interface or to a [CARP](#) group.

When you set the IP address, the system automatically also adds a local route based on the IP address.

An interface can have more than one IP address. Unlike other systems you may work with, F5<sup>®</sup> LineRate<sup>®</sup> adds each specified IP address to the interface. Use the no form of the command to remove an IP address.

For a port channel:

- Any IP address configured on an interface can remain before adding the interface to a port channel, but the IP address is ignored. When you remove the interface from the port channel, the IP address will be active.
- You can configure IP addresses on a port channel.

### Default Setting

None

### Command Mode

config

### Syntax

`[no] ip address <addr>`

Set the IPv4 address

`[no] ip address <addr> <mask>`

Set the IPv4 address and netmask

| Parameter | Type | Description |
|-----------|------|-------------|
|-----------|------|-------------|

|      |          |   |
|------|----------|---|
| addr | IPv4Addr | IPv4 address assigned to the interface. See <a href="#">IP Address Notation</a> .             |
| mask | IPv4Addr | IPv4 address and netmask assigned to the interface. See <a href="#">IP Address Notation</a> . |

---

## ip address dhcp

Enable DHCP for IPv4 on the interface.

### Use

Use to enable or disable DHCP on the interface. Whether DHCP is enabled by default, depends on the type of F5<sup>®</sup> LineRate<sup>®</sup> installation:

- In virtual environments, DHCP is enabled on all interfaces by default.
- In nonvirtual environments, DHCP is disabled on all interfaces by default.

If you enable DHCP, you can still configure static IP addresses on the interface, including the same address assigned by DHCP. You can have only one DHCP IP address on any single interface.

Be sure to keep DHCP on at least one interface in a virtual environment to ensure that you can access the system.

You cannot configure a loopback interface, for example lo0, to use DHCP.

Enabling DHCP also automatically enables the `client request router` option or the `/config/system/interface/<intf_name>/ip/dhcp/clientOption/router` node (data key value of 1), which tells the system to use the DHCP-derived default route from this interface.

While more than one interface can have DHCP enabled, only one interface can have the router option enabled. After manually enabling DHCP on one interface, you must disable the router option on the each subsequent interface before enabling DHCP (`no ip dhcp client request router` or data key value of 0 on `/config/system/interface/<intf_name>/ip/dhcp/clientOption/router`).

A manually configured default IP route will override any default route obtained from DHCP.

### Default Setting

Whether DHCP is enabled by default, depends on the type of F5<sup>®</sup> LineRate<sup>®</sup> installation:

- In virtual environments, DHCP is enabled on all interfaces by default.
- In nonvirtual environments, DHCP is disabled on all interfaces by default.

## Command Mode

config

## Syntax

```
[no] ip address dhcp
```

Enable dhcp on the interface

```
[no] ip dhcp client request router
```

Use the default route acquired from DHCP

## Related

CLI Reference Guide - [IP Mode Commands](#)

---

## ipv6 address

Set IPv6 address for the interface.

## Use

You can configure more than one IP address on an interface. Each virtual IP must also be assigned to an interface or to a [CARP](#) group.

When you set the IP address, the system automatically also adds a local route based on the IP address.

An interface can have more than one IP address. Unlike other systems you may work with, F5<sup>®</sup> LineRate<sup>®</sup> adds each specified IP address to the interface. Use the no form of the command to remove an IP address.

For a port channel:

- Any IP address configured on an interface can remain before adding the interface to a port channel, but the IP address is ignored. When you remove the interface from the port channel, the IP address will be active.
- You can configure IP addresses on a port channel.

## Default Setting

None

## Command Mode

config

## Syntax

```
[no] ipv6 address <addrMask>
```

Specifies an IPv6 address.

```
[no] ipv6 address <addrMask> link-local
```

Specifies that the IPv6 address is link-local. Address must begin with fe80.

```
[no] ipv6 enable
```

Enables an automatically generated link-local address on the interface, even if no other IPv6 addresses are configured.

| Parameter | Type         | Description   |
|-----------|--------------|---|
| addrMask  | IPv6AddrMask | IPv6 address and prefix bits. See <a href="#">IP Address Notation</a> |

---

## mtu

Interface maximum transmission unit (MTU).

### Use

Sets the MTU for the Ethernet interface. When using VLANs, how the system takes into account the VLAN header varies based on the Ethernet hardware and driver.

Different Ethernet hardware and associated drivers implement different types of support for VLAN. Some provide the ability to create slightly longer packets (such as 1508 bytes). If the hardware and driver support the ability to add the VLAN header overhead in addition to the MTU, the system does that and generates packets up to 1508. If the hardware and driver do not support adding the VLAN header, the system lowers the MTU then adds the VLAN header, resulting in packets that are the MTU size.

F5<sup>®</sup> LineRate<sup>®</sup> software supports jumbo frames up to 9000 bytes. However, some Ethernet devices have lower MTU limits.

For assistance in determining what your hardware/driver supports, contact F5<sup>®</sup> [technical support](#).

For a port channel:

- Any MTU configured on an interface can remain before adding the interface to a port channel, but the MTU is ignored. When you remove the interface from the port channel, the MTU will be active.

- You can configure MTU on a port channel.

### Default Setting

1500

### Command Mode

config

### Syntax

```
mtu <mtu>
```

Interface maximum transmission unit (MTU)

```
no mtu
```

Remove the configured MTU

| Parameter | Type    | Description      |
|-----------|---------|------------------|
| mtu       | Integer | MTU size (bytes) |

---

## shutdown

Disable the interface.

### Use

You may want to shut down interfaces that you are not using. Shutting down an interface prevents traffic from entering or leaving that interface and also shuts down all CARP groups attached to that interface.

### Default Setting

None

### Command Mode

config

### Syntax

```
shutdown
```

Disable the interface



---

## CARP Example - Active/Standby

1. [CARP Overview - Active/Standby Configuration](#)
2. [What You Need](#)
3. [How the Configuration Works](#)
4. [Annotated Configuration](#)
5. [Example Show Run Output](#)

---

## CARP Overview - Active/Standby Configuration



**Note:** For Amazon EC2 instances, EC2 networking does not support CARP.

---

Configuring CARP on interfaces permits failover for one network segment between two or more F5<sup>®</sup> LineRate<sup>®</sup> systems. This example shows an active/standby configuration where CARP is configured on the outside interfaces (client access).

In the active/standby configuration (shown below), the CARP group on one F5<sup>®</sup> LineRate<sup>®</sup> system is configured as the active group, based on its lower priority. The other F5<sup>®</sup> LineRate<sup>®</sup> system is configured identically, except the CARP group has a higher priority, making it the standby.

To focus on how CARP works, this example shows only the outside segment (network traffic coming into the F5<sup>®</sup> LineRate<sup>®</sup> system).

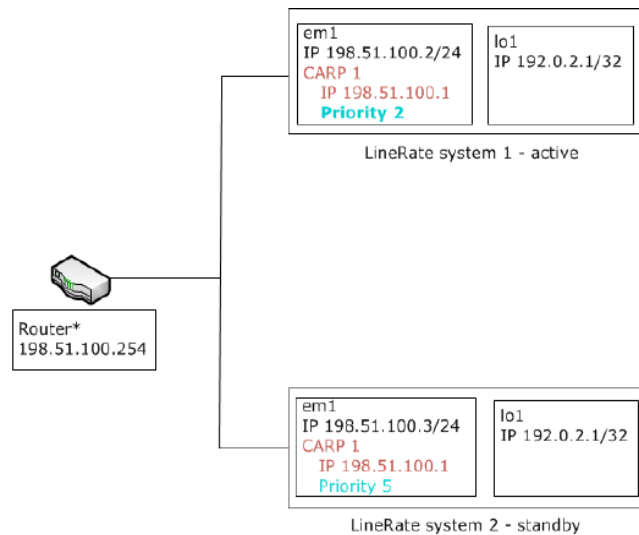

\* IP route configured as:  
192.0.2.1 255.255.255.255 198.51.100.1

Example active/standby configuration using CARP

## What You Need

For this configuration, as shown above, you need the following:

- One router
- Two F5<sup>®</sup> LineRate<sup>®</sup> systems with the following:
  - One loopback interface on each
  - One outside interface on each
- IP addresses for the following:
  - One for the router
  - One for the virtual IP (will also be the IP address for the loopback interface)
  - One for the outside interfaces (one unique IP each)
  - One for the CARP group

## How the Configuration Works

The code example in the next section sets up the following configuration (including some items not shown in the diagram above):

- Each F5<sup>®</sup> LineRate<sup>®</sup> system is configured as follows:
  - Each outside interface (on em1) has a unique IP address (198.51.100.2/24 and 198.51.100.3/24).

- Each outside interface is part of CARP group 1 with the shared CARP IP set to 198.51.100.1. The shared CARP IP is used as a next hop gateway address for the router to reach the virtual IP address.
  - The priority on the active system is set to 2.
  - The priority of the standby system is set to 5.
- The virtual IP address is configured as 192.0.2.1 80.
- A loopback interface is configured with the virtual IP as its address (192.0.2.1/32).
- The virtual IP address is attached to a virtual server.
- The real servers are attached to the virtual server.
- The default IP route on each F5<sup>®</sup> LineRate<sup>®</sup> system is set to 0.0.0.0/0 198.51.100.254.
- The router is configured via a static IP route to send requests for destination IP 192.0.2.1 (the VIP) to 198.51.100.1 (the CARP IP).

Requests to the virtual IP 192.0.2.1 are sent to through the router, which sends them to the active system based on its routing and the CARP priority. The active system then sends the requests to the virtual server and to the real server. If anything in the path to the active system's em1 interface fails, the standby system will become master for the CARP group and will accept traffic for 192.0.2.1 (the VIP) using 198.51.100.1 (the CARP IP).

The configuration on all F5<sup>®</sup> LineRate<sup>®</sup> systems meant for CARP failover must have the identical configuration, *except* for the following:

- Host name
- Unique management IP
- Unique IP on each CARP interface
- CARP priority

---

## Annotated Configuration

Below is the configuration that is key to configuring active/passive CARP. We have excluded parts of the configuration to focus only on what is required for this CARP configuration to work. In the section below, we have included the complete show run output, which has the complete configuration for a simple load balancer using active/passive CARP for the outside interface for both systems.

Configuration for F5<sup>®</sup> LineRate<sup>®</sup> system 1 (active):

| Commands   | Description                                       |
|--|---|
| <pre>interface em1   ip address 198.51.100.2/24   carp 1</pre> | Sets the unique IP address for the interface em1. |

| Commands   | Description  |
|--|--|
| <pre>priority 2 ip 198.51.100.1</pre>  | <p>Adds CARP group 1 with a priority of 2 on the em1 interface, making this system the master, and sets the shared CARP IP address.</p>  |
| <pre>interface lo1 ip address 192.0.2.1/32</pre>   | <p>Sets the IP address for the loopback interface lo1, which is the same as the virtual IP created below.</p>  |
| <pre>ip route 0.0.0.0/0 198.51.100.254</pre>   | <p>Sets the system's default IP route for all traffic to 198.51.100.254, the router's IP address.</p>  |
| <pre>real-server base webserver_base  real-server rs1 ip address 10.1.2.101 80 base webserver_base admin-status online</pre> | <p>Creates a real server base (base settings omitted for this example) webserver_base.</p> <p>Creates a real server called rs1 based on webserver_base, assigns 10.1.2.101 as the real server's IP address, and brings the real server online.</p> |
| <pre>virtual-ip base web_base admin-status online  virtual-ip vip1 ip 192.0.2.1 80 base web_base</pre>                       | <p>Creates a virtual IP base (base settings omitted for this example) web_base.</p> <p>Creates a virtual IP called vip1 based on web_base, assigns 192.0.2.1 as the virtual IP address, and brings the virtual IP base online.</p>                 |
| <pre>virtual-server vs1 lb-algorithm round-robin service http attach virtual-ip vip1 default attach real-server rs1</pre>    | <p>Creates the virtual server vs1 and attaches the virtual IP vip1 and the real server rs1 to it.</p> <p>Also sets the load balancing algorithm and service to HTTP</p>  |

Configuration for F5<sup>®</sup> LineRate<sup>®</sup> system 2 (standby; configuration differences from system 1 shown in blue):

| Commands   | Description  |
|--|--|
| <pre>interface em1   ip address 198.51.100.3/24   carp 1     priority 5   ip 198.51.100.1</pre>                                    | <p>Sets the unique IP address for the interface em1.</p> <p>Adds CARP group 1 with a priority of 5 on the em1 interface, making this system the standby, and sets the shared CARP IP address.</p>  |
| <pre>interface lo1   ip address 192.0.2.1/32</pre>   | <p>Sets the IP address for the loopback interface lo1, which is the same as the virtual IP created below.</p>  |
| <pre>ip route 0.0.0.0/0 198.51.100.254</pre>   | <p>Sets the system's default IP route for all traffic to 198.51.100.254, the router's IP address.</p>  |
| <pre>real-server base webserver_base  real-server rs1   ip address 10.1.2.101 80   base webserver_base   admin-status online</pre> | <p>Creates a real server base (base settings omitted for this example) webserver_base.</p> <p>Creates a real server called rs1 based on webserver_base, assigns 10.1.2.101 as the real server's IP address, and brings the real server online.</p> |
| <pre>virtual-ip base web_base   admin-status online  virtual-ip vip1 ip 192.0.2.1 80   base web_base</pre>                         | <p>Creates a virtual IP base (base settings omitted for this example) web_base.</p> <p>Creates a virtual IP called vip1 based on web_base, assigns 192.0.2.1 as the virtual IP address, and brings the virtual IP base online.</p>                 |
| <pre>virtual-server vs1   lb-algorithm round-robin   service http   attach virtual-ip vip1 default   attach real-server rs1</pre>  | <p>Creates the virtual server vs1 and attaches the virtual IP vip1 and the real server rs1 to it.</p> <p>Also sets the load balancing algorithm and service to HTTP</p>  |

---

## Example Show Run Output

The show run output below includes only the sections related to an active/standby CARP configuration.

### Configuration for F5® LineRate® system 1 (active):

```
Building configuration...
!
hostname example-host-a
!
username admin secret encrypted "$2a$04$7TYufYOKVQ8i8bblVtZ1ierxZXzcH5mR/
  QeazH8WnWRzVEkPt0MgS" uid 2000
!
interface em1
  ip address 198.51.100.2 255.255.255.0
  carp 1
    priority 2
    ip 198.51.100.1
!
interface lol
  ip address 192.0.2.1 255.255.255.255
!
ip route 0.0.0.0/0 198.51.100.254
!
real-server base webserver_web
!
real-server rs1
  ip address 10.1.2.101 80
  base webserver_base
  admin-status online
!
virtual-ip base web_base
  admin-status online
!
virtual-ip vip1 ip 192.0.2.1 80 base web_base
!
virtual-server vs1
  lb-algorithm round-robin
  service http
  attach virtual-ip vip1 default
  attach real-server rs1
```

### Configuration for F5® LineRate® system 2 (standby):

```
Building configuration...
!
hostname example-host-b
!
username admin secret encrypted "$2a$04$7TYufYOKVQ8i8bblVtZ1ierxZXzcH5mR/QeazH8WnWRzVEkPt0MgS" uid
  2000
!
```

```
interface em1
 ip address 198.51.100.3 255.255.255.0
 carp 1
  priority 5
  ip 198.51.100.1
!
interface lo1
 ip address 192.0.2.1 255.255.255.255
!
ip route 0.0.0.0/0 198.51.100.254
!
real-server base webserver_web
!
real-server rs1
 ip address 10.1.2.101 80
 base webserver_base
 admin-status online
!
virtual-ip base web_base
 admin-status online
!
virtual-ip vip1 ip 192.0.2.1 80 base web_base
!
virtual-server vs1
 lb-algorithm round-robin
 service http
 attach virtual-ip vip1 default
 attach real-server rs1
```

---

## CARP Example - Active/Active

1. [CARP Overview - Active/Active Configuration](#)
2. [What You Need](#)
3. [How the Configuration Works](#)
4. [Annotated Configuration](#)
5. [Example Show Run Output](#)

---

## CARP Overview - Active/Active Configuration



**Note:** For Amazon EC2 instances, EC2 networking does not support CARP.

---

Configuring CARP on interfaces permits failover for one network segment between two or more F5<sup>®</sup> LineRate<sup>®</sup> systems. This example shows an active/active configuration where CARP is configured on the outside interfaces (client access).

In the active/active configuration (shown below), you use two CARP groups and configure both on each system. The difference is that CARP 1 is active on system 1 and standby on system 2, based on its lower priority. Conversely, CARP 2 is standby on system 1 and active on system 2, based on its higher priority.



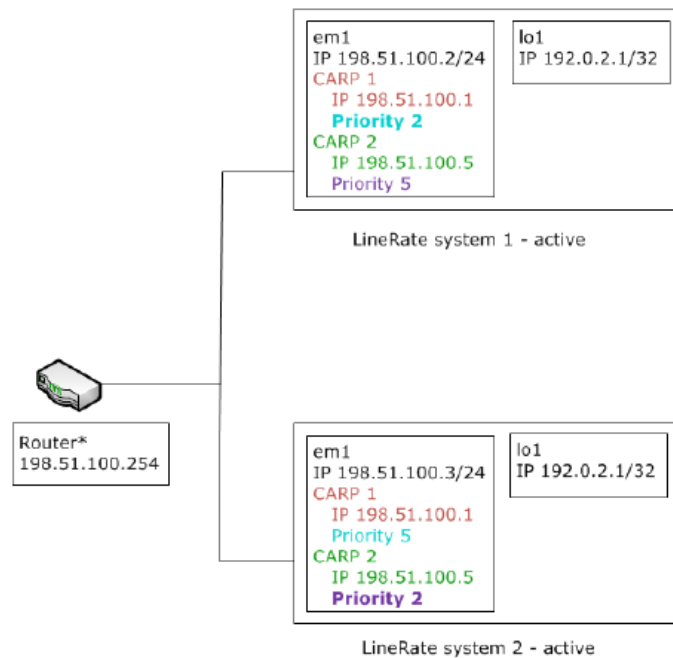

\* IP routes configured as:  
 192.0.2.1 255.255.255.255 198.51.100.1  
 192.0.2.1 255.255.255.255 198.51.100.5

Example active/active configuration using CARP

To focus on how CARP works, this example shows only the outside segment (network traffic coming into the F5<sup>®</sup> LineRate<sup>®</sup> system). CARP works between interfaces in the group for one network segment (for example, inbound or outbound, but not both).

## What You Need

For this configuration, as shown above, you need the following:

- One router that supports [Equal Cost Multi-Path \(ECMP\)](#) routing, using flow affinity or hashing.
- Two F5<sup>®</sup> LineRate<sup>®</sup> systems with the following:
  - One loopback interface on each
  - One outside interface on each
- IP addresses for the following:
  - One for the router
  - One for the virtual IP (will also be the IP address for the loopback interface)
  - One for the real server
  - Two for the outside interfaces (unique IP address assigned to each)
  - Two for the CARP groups (one IP address for each group)



If your router does not support ECMP or cannot use hashing or flow affinity to distribute all packets for the same TCP flow to the same next hop gateway, you can still use active/active CARP, but you must use more than one virtual IP. In that scenario, no two systems will be able to be active for a single virtual IP at once, because the router cannot distribute traffic for a single IP to multiple active systems.

---

## How the Configuration Works

The code example in the next section sets up the following configuration (including some items not shown in the diagram above):

- Each F5<sup>®</sup> LineRate<sup>®</sup> system is configured as follows:
  - Each outside interface (on em1) has a unique IP address (198.51.100.2/24 and 198.51.100.3/24).
  - Each outside interface is part of CARP group 1 with the shared CARP IP set to 198.51.100.1. The shared CARP IP is used as a next hop gateway address for the router to reach the virtual IP address.
    - The priority on system 1 (the active system) is set to 2.
    - The priority on system 2 (the standby system) is set to 5.
  - Each outside interface is also part of CARP group 2 with the shared CARP IP set to 198.51.100.5. The shared CARP IP is used as a next hop gateway address for the router to reach the virtual IP address.
    - The priority on system 2 (the active system) is set to 2.
    - The priority on system 1 (the standby system) is set to 5.
  - The virtual IP address is configured as 192.0.2.1 80.
  - A loopback interface is configured with the virtual IP as its address (192.0.2.1/32).
  - The virtual IP address is attached to the virtual server.
  - The real servers are attached to the virtual server.
  - The default IP route on each F5<sup>®</sup> LineRate<sup>®</sup> system is set to 0.0.0.0/0 198.51.100.254.
- The router is configured with two static routes, both to the same virtual IP address as the destination, but with the two shared CARP IP addresses as the next hop addresses:
  - 192.0.2.1 (VIP) via gateway IP 198.51.100.1 (the CARP 1 IP)
  - 192.0.2.1 (VIP) via gateway IP 198.51.100.5 (the CARP 2 IP)

Requests to the virtual IP 192.0.2.1 are sent to the router, which uses Equal Cost Multi-Path (ECMP) hashing to send some TCP flows to CARP group 1 and the rest of the flows to CARP group 2. If both F5<sup>®</sup> LineRate<sup>®</sup> systems are operational and their interfaces are up, that means F5<sup>®</sup> LineRate<sup>®</sup> system 1 will receive all traffic for CARP group 1 and F5<sup>®</sup> LineRate<sup>®</sup> system 2 will receive all traffic for CARP group 2. If one of the systems fails or its interface goes down, the remaining system will receive all traffic for both CARP groups.

Although this example shows only two systems in the F5<sup>®</sup> LineRate<sup>®</sup> cluster for simplicity, this can be extended to a larger cluster with an arbitrary number of active systems and an additional number of standby systems. You need one CARP group per **active** system in this configuration. All systems should have all CARP groups configured, but each with different priorities for that group.

The configuration on all F5<sup>®</sup> LineRate<sup>®</sup> systems meant for CARP failover must have the identical configuration, *except* for the following:

- Host name
- Unique management IP
- Unique IP on each CARP interface
- CARP priority



The real servers in this active/active configuration cannot use the client-source-address NAT profile (`attach nat profile builtin client-source-address`). Using this NAT profile would not permit the real server to know which F5<sup>®</sup> LineRate<sup>®</sup> system to send traffic back to, because the real server would only know the client's IP address not the IP address of the F5<sup>®</sup> LineRate<sup>®</sup> system.

---

## Annotated Configuration

Below is the configuration that is key to configuring active/active CARP. We have excluded parts of the configuration to focus only on what is required for this CARP configuration to work. In the section below, we have included the complete show run output, which has the complete configuration for a simple load balancer using active/active CARP for the outside interface for both systems.

Configuration for F5<sup>®</sup> LineRate<sup>®</sup> system 1 (active):

| Commands  | Description   |
|---|---|
| <pre>interface em1   ip address 198.51.100.2/24   carp 1     priority 2     ip 198.51.100.1   carp 2     priority 5     ip 198.51.100.5</pre> | <p>Sets the unique IP address for the interface em1.</p> <p>Adds CARP group 1 with a priority of 2 on the em1 interface, making this system the master, and sets the shared CARP IP address.</p> <p>Adds CARP group 2 with a priority of 5 on the em1 interface, making this system the standby, and sets the shared CARP IP address.</p> |

| Commands   | Description  |
|--|--|
| <pre>interface lo1   ip address 192.0.2.1/32</pre>   | <p>Sets the unique IP address for the loopback interface lo1, which is the same as the virtual IP created below.</p>   |
| <pre>ip route 0.0.0.0/0 198.51.100.254</pre>   | <p>Sets the system's default IP route for all traffic to 198.51.100.254, the router's IP address.</p>  |
| <pre>real-server base webserver_base  real-server rs1   ip address 10.1.2.101 80   base webserver_base   admin-status online</pre> | <p>Creates a real server base (base settings omitted for this example) webserver_base.</p> <p>Creates a real server called rs1 based on webserver_base, assigns 10.1.2.101 as the real server's IP address, and brings the real server online.</p> |
| <pre>virtual-ip base web_base   admin-status online  virtual-ip vip1 ip 192.0.2.1 80   base web_base</pre>                         | <p>Creates a virtual IP base (base settings omitted for this example) web_base.</p> <p>Creates a virtual IP called vip1 based on web_base, assigns 192.0.2.1 as the virtual IP address, and brings the virtual IP base online.</p>                 |
| <pre>virtual-server vs1   lb-algorithm round-robin   service http   attach virtual-ip vip1 default   attach real-server rs1</pre>  | <p>Creates the virtual server vs1 and attaches the virtual IP vip1 and the real server rs1 to it.</p> <p>Also sets the load balancing algorithm and service to HTTP</p>  |

Configuration for F5<sup>®</sup> LineRate<sup>®</sup> system 2 (active; configuration differences from system 1 shown in blue):

| Commands  | Description   |
|---|---|
| <pre>interface em1   ip address 198.51.100.3/24   carp 1     priority 5     ip 198.51.100.1   carp 2     priority 2     ip 198.51.100.5</pre> | <p>Sets the unique IP address for the interface em1.</p> <p>Adds CARP group 1 with a priority of 5 on the em1 interface, making this system the standby, and sets the shared CARP IP address.</p> <p>Adds CARP group 2 with a priority of 2 on the em1 interface, making this system the master, and sets the shared CARP IP address.</p> |
| <pre>interface lo1   ip address 192.0.2.1/32</pre>  | <p>Sets the unique IP address for the loopback interface lo1, which is the same as the virtual IP created below.</p>  |
| <pre>ip route 0.0.0.0/0 198.51.100.254</pre>  | <p>Sets the system's default IP route for all traffic to 198.51.100.254, the router's IP address.</p>   |
| <pre>real-server base webserver_base real-server rs1   ip address 10.1.2.101 80   base webserver_base   admin-status online</pre>             | <p>Creates a real server base (base settings omitted for this example) webserver_base.</p> <p>Creates a real server called rs1 based on webserver_base, assigns 10.1.2.101 as the real server's IP address, and brings the real server online.</p>  |
| <pre>virtual-ip base web_base   admin-status online virtual-ip vip1 ip 192.0.2.1 80   base web_base</pre>                                     | <p>Creates a virtual IP base (base settings omitted for this example) web_base.</p> <p>Creates a virtual IP called vip1 based on web_base, assigns 192.0.2.1 as the virtual IP address, and brings the virtual IP base online.</p>  |
| <pre>virtual-server vs1   lb-algorithm round-robin   service http   attach virtual-ip vip1 default   attach real-server rs1</pre>             | <p>Creates the virtual server vs1 and attaches the virtual IP vip1 and the real server rs1 to it.</p> <p>Also sets the load balancing algorithm and service to HTTP</p>   |

| Commands | Description |
|----------|-------------|
|          |             |

---

## Example Show Run Output

The show run output below includes only the sections related to an active/active CARP configuration.

### Configuration for F5® LineRate® system 1 (active):

Building configuration...

```
!  
hostname example-host-a  
!  
username admin secret encrypted "$2a$04$7TYufYOKVQ8i8bblVtZ1ierxZXzcH5mR/  
QeaZH8WnWRzVEkPt0MgS" uid 2000  
!  
interface em1  
 ip address 198.51.100.2 255.255.255.0  
 carp 1  
   priority 2  
   ip 198.51.100.1  
 carp 2  
   priority 5  
   ip 198.51.100.5  
!  
interface lo1  
 ip address 192.0.2.1 255.255.255.255  
!  
ip route 0.0.0.0/0 198.51.100.254  
!  
real-server base webserver_web  
!  
real-server rsl  
 ip address 10.1.2.101 80  
 base webserver_base  
 admin-status online  
!  
virtual-ip base web_base  
 admin-status online  
!  
virtual-ip vip1 ip 192.0.2.1 80 base web_base  
!  
virtual-server vs1  
 lb-algorithm round-robin  
 service http  
 attach virtual-ip vip1 default  
 attach real-server rsl
```

## Configuration for F5® LineRate® system 2 (active):

Building configuration...

```
!  
hostname example-host-b  
!  
username admin secret encrypted "$2a$04$7TYufYOKVQ8i8bb1VtZ1ierxZXzcH5mR/QeaZH8WnWRzVEkPt0MgS" uid  
    2000  
!  
interface em1  
    ip address 198.51.100.3 255.255.255.0  
    carp 1  
        priority 5  
        ip 198.51.100.1  
    carp 2  
        priority 2  
        ip 198.51.100.5  
!  
interface lo1  
    ip address 192.0.2.1 255.255.255.255  
!  
ip route 0.0.0.0/0 198.51.100.254  
!  
real-server base webserver_web  
!  
real-server rs1  
    ip address 10.1.2.101 80  
    base webserver_base  
    admin-status online  
!  
virtual-ip base web_base  
    admin-status online  
!  
virtual-ip vip1 ip 192.0.2.1 80 base web_base  
!  
virtual-server vs1  
    lb-algorithm round-robin  
    service http  
    attach virtual-ip vip1 default  
    attach real-server rs1
```

---

## IP Mode Commands

1. [ip dns](#)
  1. [admin-status](#)
  2. [domain-list](#)
  3. [name-server](#)
  4. [retries](#)
  5. [timeout](#)
2. [ip route](#)
3. [ipv6 route](#)
4. [ip routing](#)
5. [ip filter-list](#)
  1. [priority](#)

Use the following commands to configure global IP settings.

---

### ip dns

Configure parameters for domain name resolution.

#### Use

Use to configure system-wide settings for Domain Name System (DNS), which allows the name-to-IP resolution of domain names.

---



**Note:** By default, the system comes with a ready-to-use DNS configuration. You can use the default servers or configure the system to use your own servers.

---

#### Default Setting

None

#### Command Mode

configure

#### Syntax



`[no] ip dns`

Configure parameters for domain name resolution.

## Related Commands

REST API Reference - [dns](#)

---

## admin-status

Bring an object, such as a health monitor, real server, or virtual IP, online or offline. After you create an object, you must bring it online.

### Use

You typically set the offline status only when you want to disable the object or block connections to the web server during maintenance or system reconfiguration.

### Default Setting

offline

### Command Mode

config

### Syntax

`admin-status offline`

Bring the object offline

`admin-status online`

Bring the object online

`no admin-status`

Remove the directly configured admin status

---

## domain-list

Configure a list of domains to search to complete unqualified host names.

### Use

Use to configure up to six domains to search to complete unqualified host names. Enter the domains, in priority order, separated by spaces and the whole string surrounded by double quotes. Use up to a total of 256 characters. The system searches the list in the order entered.

### Default Setting

None

### Command Mode

config-ip-dns

### Syntax

```
domain-list <domain_list>
```

Configure a list of domains to search to complete unqualified host names.

| Parameter   | Type   | Description  |
|-------------|--------|--|
| domain_list | String | Space-separated list of domains to search, each to be tried in turn. The search list is limited to 6 domains with a total of 256 characters. |

---

## name-server

Configure a space-separated prioritized list of domain name servers.

### Use

Use to configure up to three domain name servers. Enter the IP addresses, in priority order, separated by spaces.



**Note: By default, the system is configured with two domain name servers (8.8.8.8 and 8.8.4.4). These are the Google Public DNS servers. You can continue to use these servers or configure the system to use your own servers.**

---

### Default Setting

None

### Command Mode

config-ip-dns

### Syntax

`name-server <addr1> [<addr2>] [<addr3>]`

| Parameter | Type   | Description  |
|-----------|--------|--|
| addr1     | IPAddr | IPv4 or IPv6 address of first name server.             |
| addr2     | IPAddr | IPv4 or IPv6 address of second, optional, name server. |
| addr3     | IPAddr | IPv4 or IPv6 address of third, optional, name server.  |

---

## retries

Configure number of times to retry a name server request.

### Use

Use to configure the number of times the system tries to contact each domain name server, after the first contact. The system tries each name server in the list, then starts the retries of each server.

The default is 1 retries. The maximum permitted is 4 retries. To configure no retries, set to 0.

### Default Setting

1

### Command Mode

config-ip-dns

### Syntax

`[no] retries <dns_retries>`

Configure number of times to retry a request

| Parameter   | Type    | Description   |
|-------------|---------|---|
| dns_retries | Integer | Number of times a request must be retried on each name server before giving up. Default is 1, allowed maximum is 4. |

---

## timeout

Configure the initial amount of time to wait for a response from a name server before retrying the query.

## Use

Use to configure how long the system should wait for a reply from a domain name server, before trying the next server.

The default is 3 seconds. The maximum permitted is 30 seconds.

## Default Setting

3

## Command Mode

config-ip-dns

## Syntax

```
[no] timeout <dns_timeout>
```

Configure the initial amount of time to wait for a response from a name server before retrying the query.

| Parameter   | Type    | Description   |
|-------------|---------|---|
| dns_timeout | Integer | Initial timeout value in seconds. Default is 3 seconds, allowed maximum is 30 seconds. The resolver uses the initial timeout value for the first retry, and applies an exponential back-off algorithm for subsequent retries. |

---

## ip route

Configure global IPv4 settings.

## Use

Use to configure the IPv4 routes for the system. You can set routes to go through a specific system interface or through another system, likely a router, on your network. Be sure to configure routes to include every subnet the system needs.

When configuring routes, you can set the MTU to use for that route. You can also set an MTU for each system interface, but the interface MTU will be overridden by the MTU setting here. Determine your MTU based on your network infrastructure.

## Default Setting

None

## Command Mode

configure

## Syntax

```
[no] ip route <subnet_cidr> <intf_name> [mtu <mtu>]
```

Set the IPv4 route through a system interface; optionally specify the MTU for this route

```
[no] ip route <v4_subnet> <v4_mask> <intf_name> [mtu <mtu>]
```

Set the IPv4 route through a system interface; optionally specify the MTU for this route

```
[no] ip route <subnet_cidr> <next_hop> [mtu <mtu>]
```

Set the IPv4 route through a router; optionally specify the MTU for this route

```
[no] ip route <v4_subnet> <v4_mask> <v4_next_hop> [mtu <mtu>]
```

Set the IPv4 route through a router; optionally specify the MTU for this route

| Parameter   | Type       | Description   |
|-------------|------------|---|
| intf_name   | String     | Name of an interface where all hosts on the destination network are directly connected. |
| mtu         | Integer    | MTU for this route  |
| v4_subnet   | IPv4Addr   | Destination subnet in dotted decimal notation.  |
| v4_mask     | IPv4Addr   | Destination subnet mask in dotted decimal notation.                                     |
| v4_next_hop | IPv4Addr   | Forwarding router's address.  |
| subnet_cidr | IPAddrMask | Destination subnet and prefix length using CIDR notation.                               |
| next_hop    | IPAddr     | Forwarding router's address.  |

## Related Commands

[Interface Mode Commands](#)

REST API Reference - [ip](#)

---

## ipv6 route

Configure global IPv6 settings.

### Use

Use to configure the IPv6 routes for the system. You can set routes to go through a specific system interface or through another system, likely a router, on your network. Be sure to configure routes to include every subnet the system needs.

### Default Setting

None

### Command Mode

configure

### Syntax

```
[no] ipv6 route <v6_addr> <intf_name>
```

Set the IPv6 route through a system interface.

```
[no] ipv6 route <v6_addr> <intf_name> <v6_next_hop>
```

Set the IPv6 route through a router.

```
[no] ipv6 route <v6_addr> <v6_next_hop>
```

Set the IPv6 route through a router.

| Parameter   | Type         | Description   |
|-------------|--------------|---|
| intf_name   | String       | Name of an interface where all hosts on the destination network are directly connected or name of the interface for a link-local address. |
| v6_addr     | IPv6AddrMask | Destination network and prefix length   |
| v6_next_hop | IPv6Addr     | Forwarding router's address   |

### Related Commands

[Interface Mode Commands](#)

---

## ip routing

Enable or disable permitting packets to flow through the system.

## Use

Use to enable or disable IP gateway function to allow packets to flow through the system.

Enable when F5® LineRate® is the only gateway to another network, such as the Internet.

## Default Setting

Disabled

## Command Mode

configure

## Syntax

```
[no] ip routing
```

Enables forwarding of IP traffic through the system

---

# ip filter-list

Configure rules to allow or deny traffic.

## Use

An IP filter is an ordered list of rules that you can apply to IP traffic to permit some traffic and deny other traffic. IP filters are highly scalable and can support over 100,000 rules in a single list. You can attach one IP filter list to a virtual IP to permit or deny traffic from specific client source IP addresses or subnets. To see the order in which the rules are processed, use:

- CLI command—`show run`
- REST API—`/status/config/running`

You can create multiple IP filter lists to use with different virtual IPs.

Each filterlist has an implicit deny rule as its lowest priority filter. Traffic that does not match any of the explicitly configured filters will be dropped as it always matches the implicit deny rule.

## Default Setting

None

## Command Mode

config

## Syntax

```
[no] ip filter-list <filter_name>
```

Create a list of IP addresses and networks used for filtering

| Parameter   | Type | Description                |
|-------------|------|----------------------------|
| filter_name | Word | Name of the IP filter list |

## Related Commands

[virtual-ip attach ip-filter](#)

[show ip filter-list](#)

---

## priority

Configure the priority of IP filter rules.

### Use

Configure the priority of a rule as a real number. Rules are ordered from low to high, with lower numbers representing higher priority. Multiple rules can share the same priority. You can insert a new rule at a new priority between two existing rules by choosing a priority number between those two rules, including a fractional priority number.

The system processes the rules with the highest priority first, then works through to the lower priority rules.

### Default Setting

None

### Command Mode

config

### Syntax

```
[no] <priority> deny <addr>
```

Automatically close connections from IP addresses that match this rule without processing any requests.

```
[no] <priority> deny <addrMask>
```



Automatically close connections from IP addresses that match this rule without processing any requests.

```
[no] <priority> permit <addr>
```

Process requests from IP addresses that match this rule

```
[no] <priority> permit <addrMask>
```

Process requests from IP addresses that match this rule

| Parameter | Type       | Description   |
|-----------|------------|---|
| addr      | IPAddr     | IPv4 or IPv6 host address to match. See <a href="#">IP Address Notation</a> .   |
| addrMask  | IPAddrMask | IPv4 or IPv6 subnet and mask to match. See <a href="#">IP Address Notation</a> .  |
| priority  | Real       | Priority of this rule is a floating point (real) number, in decimal, with 9 digits of precision ALWAYS and no leading zeros. Rules are ordered from low to high, with lower numbers representing higher priority. |

---

## Key Mode Commands

Use the following commands to configure cryptographic keys for use with SSL.

1. [key](#)
2. [pem-format](#)

---

### key

Create or modify a cryptographic key.

#### Use

You set up a private key object to correspond to each primary certificate you need. The system supports using one private key to generate more than one primary certificate and the use of separate private keys for individual primary certificates.

You need access to your private key file. The F5<sup>®</sup> LineRate<sup>®</sup> software supports keys in PEM format.



#### Best Practices:

- Configure primary certificates and corresponding keys for each cipher type that clients may use, then attach the configured certificate/key pairs to the SSL profile. For example, for clients that support ECC or RSA ciphers, you may want to configure and attach both RSA and ECC certificates and keys.
- Give each key a meaningful name that helps identify the key. For example, you might use the domain name or security settings in the name.

---

For more information about keys, see [Managing SSL](#).

#### Default Setting

By default, the system creates a key, certificate, and SSL profile, each called self-signed, that you can use to test the SSL function.

#### Command Mode

configure

#### Syntax

[no] **key** <key\_name>

Create or modify a cryptographic key

| Parameter | Type | Description            |
|-----------|------|------------------------|
| key_name  | Word | Name of the key object |

### Example

See [Setting Up Certificates for SSL Termination](#)

### Related Commands

[Certificate Mode Commands](#)

[SSL Mode Commands](#)

REST API Reference - [keys](#)

---

## pem-format

Specify the key content in a PEM-encoded (base64) string.

### Use

Use to paste key content into a key.

- CLI command—After entering the command, press **Enter** to paste key text. Type **quit** to finish.
- REST API—Paste the key text into the data key.

### Default Setting

None

### Command Mode

config

### Syntax

**pem-format**

Specify the key content in a PEM-encoded (base64) string.

### Example

See [Setting Up Certificates for SSL Termination](#)

## **Related Commands**

[Certificate Mode Commands](#)

[SSL Mode Commands](#)

---

## Licensing Mode Commands (config)

1. [licensing](#)
  1. [activation](#)
  2. [feature](#)
  3. [regkey](#)
  4. [revocation-list](#)
  5. [signing-certificate](#)

---

## licensing

Configure licensing.

### Use

Use to configure the system registration key, automatic licensing, and to paste the copied license text.

To purchase a subscription license, go to [linerate.f5.com/try](https://linerate.f5.com/try). For other licensing options, [contact sales](#).

After you install F5<sup>®</sup> LineRate<sup>®</sup>, you can install the license.

The following are required for your purchased license to automatically renew:

- The credit card on file must be active and must process the purchase or renewal.
- The F5<sup>®</sup> LineRate<sup>®</sup> hardware must have Internet connectivity.
- A F5<sup>®</sup> LineRate<sup>®</sup> interface must be configured with either DHCP or a default route and IP address.
- F5<sup>®</sup> LineRate<sup>®</sup> must have licensing set to auto.



**Note:** If your F5<sup>®</sup> LineRate<sup>®</sup> system does not meet one or more of the criteria, you can manually install and renew the license before the license period expires. See [Manually Installing a Purchased License](#).

---

The rate limits for HTTP requests, TCP connections, and Mb per second are based on the license you purchased. For more information about how licenses work, see [About Licensing](#).

Currently, the only feature you can license is called base.

For the complete licensing process, see [Configuring Licensing](#).

### **Default Setting**

None

### **Command Mode**

config

### **Syntax**

```
[no] licensing
```

Configure licensing.

### **Related**

CLI Reference Guide - [License Mode Commands \(exec\)](#)

Getting Started Guide - [Configuring Licensing](#)

REST API Reference - [licensing](#)

---

## **activation**

Configure automatic or manual licensing.

### **Use**

Use to set the system to automatic or manual license activation.

For the complete licensing process, see [Configuring Licensing](#).

### **Default Setting**

manual

### **Command Mode**

config-licensing

### **Syntax**

```
[no] activation (auto|manual|cloud)
```

Set license activation to auto or manual.

---

## feature

Install the license for a feature.

### Use

Use to install the license you receive from the <https://activate.f5.com> site. Currently, the only feature you can license is called base. The license defines the expiration date of the license, the number of HTTP connections per second, and the number of TCP connections per second.

For the CLI, copy and paste the license when prompted, then type **quit** on a line by itself.

### Default Setting

None

### Command Mode

config-licensing

### Syntax

**[no] feature base**

Install the license for base system

|  |  |  |
|--|--|--|
|  |  |  |
|  |  |  |

---

## regkey

Configure the system registration key.

### Use

Use to install the registration key that identifies your F5<sup>®</sup> LineRate<sup>®</sup> installation. After you download the F5<sup>®</sup> LineRate<sup>®</sup> installation file, you will receive an email with the registration key.

After you install the registration key, F5<sup>®</sup> LineRate<sup>®</sup> generates a dossier. The system regenerates a new dossier each time you use the **show licensing dossier** command.

### Default Setting

None

### Command Mode

config-licensing

### Syntax

[no] **regkey**

Remove system regkey

[no] **regkey** <key>

Configure system regkey

| Parameter | Type   | Description   |
|-----------|--------|---|
| key       | String | Regkey string received in email after downloading F5 <sup>®</sup> LineRate <sup>®</sup> . |

---

## revocation-list

For future use.

---

## signing-certificate

Configure X.509 licensing certificates.

### Use

For licenses that do not use a registration key, use to install the X.509 signing certificate for your license.

For the CLI, copy and paste the certificate from the email when prompted, then type **quit** on a line by itself.

### Default Setting

None

### Command Mode

config-licensing

### Syntax



[no] signing-certificate <cert\_name>

Configure X.509 licensing certificates

| Parameter | Type | Description          |
|-----------|------|----------------------|
| cert_name | Word | Name of certificate. |

---

## Load Balancer Mode Commands (Deprecated)

1. [load-balancer max-client-conns](#)
2. [load-balancer processes](#)



In F5<sup>®</sup> LineRate<sup>®</sup> version 2.0, the load-balancer command is deprecated and is replaced by the [proxy](#) command. The corresponding REST API nodes are not affected.

---

Use the following commands to configure the load balancer. These are advanced commands.

---

### load-balancer max-client-conns

#### Use

Every connection that the F5<sup>®</sup> LineRate<sup>®</sup> accepts consumes some system memory while it is being processed. The amount of memory is variable and affected by factors such as script processing, SSL offload and key size, and network conditions. If all memory on the system is exhausted, the system may terminate a proxy process to free up memory (an "out-of-memory kill"), which disrupts all traffic through that process.

We recommend correcting this situation by adding more memory to the system, dividing the load among more systems, or improving the memory efficiency of scripts. However, you can adjust this setting as a temporary solution, after consultation with technical support.

If your system experiences out-of-memory kills, you can configure this setting to allow fewer total client connections. This lessens the memory that is consumed, which prevents out-of-memory kills, but it also lessens the total number of clients that can be served at one time. When clients in excess of this limit attempt to connect, they are discarded with a TCP Reset. Many clients report this as "Connection Reset by Peer."

#### Default Setting

0 (disabled; no limit)

#### Command Mode

configure

## Syntax

```
[no] load-balancer max-client-conns <conns>
```

Maximum number of simultaneous client connections

| Parameter | Type    | Description                                       |
|-----------|---------|---|
| conns     | Integer | Maximum number of simultaneous client connections |

## Related

REST API Reference - [maxClientConns](#)

---

## load-balancer processes

### Use

Use to reduce the total number of processes dedicated to proxying traffic.

The default "auto" setting allocates the optimal number of processes. The system ignores commands to increase the number of proxy processes beyond the auto setting. Normally, you want to leave the default setting (auto), unless directed to change it by your sales engineer or technical support. Reducing the number of proxy processes may aid in script debugging or leave available CPU resources for management tasks.

The proxy processes are listed as "lb\_http" in the output of the `bash top -HS` or `bash ps aux` command. There is always one extra lb\_http process running for management.

### Default Setting

auto

### Command Mode

configure

### Syntax

```
[no] load-balancer processes <procs>
```

Setting the number of processes used for the load balancer

```
[no] load-balancer processes auto
```

Allow the system to choose how many HTTP load balancer processes to run

| Parameter | Type    | Description   |
|-----------|---------|---|
| procs     | Integer | Number of load balancer processes to run per system |

## Related

REST API Reference - [processes](#)

---

## Logging Mode Commands

1. [logging file](#)
  1. [admin-status](#)
  2. [attach](#)
2. [logging filter](#)
  1. [level](#)
3. [logging server](#)
  1. [admin-status](#)
  2. [attach](#)
  3. [ip](#)
  4. [port](#)
  5. [protocol](#)

---

## logging file

### Use

Configure logging file name and options for a local log file. The file name can be an absolute path or a path relative to the /var/log directory.

For logging to start, you must set up one or more filters, attach them, and set the admin status to online.

### Default Setting

None

### Command Mode

config

### Syntax

```
[no] logging file <file_name>
```

| Parameter | Type | Description |
|-----------|------|-------------|
|-----------|------|-------------|

|           |        |  |
|-----------|--------|--|
| file_name | String | Log file name. Can be an absolute path or a path relative to the /var/log directory. |
|-----------|--------|--|

## Related

REST API Reference - [syslog](#)

---

## admin-status

### Use

Enable or disable logging to this file.

### Default Setting

Offline

### Command Mode

loggingfile

### Syntax

```
[no] admin-status offline
```

Disable logging to this file

```
[no] admin-status online
```

Enable logging to this file

```
no admin-status
```

Remove the configured admin status

---

## attach

### Use

Attach an object, such as a filter, to this log file. If you attach multiple filters to the same file, the system logs all levels included in the filters.

### Default Setting

None

## Command Mode

loggingfile

## Syntax

```
[no] attach filter <filter_name>
```

Attach the filter to filter messages to this log file

| Parameter   | Type | Description                    |
|-------------|------|--------------------------------|
| filter_name | Word | Name of the configured filter. |

---

# logging filter

## Use

Use to create filters that set the priority/severity of messages.

## Default Setting

None

## Command Mode

config

## Syntax

```
[no] logging filter <filter_name>
```

Configure the types of the messages to log.

| Parameter   | Type | Description         |
|-------------|------|---------------------|
| filter_name | Word | Name of the filter. |

## Related

REST API Reference - [syslog](#)

---

# level

## Use

Use to configure the priority/severity of the messages to filter. Specify a single value or a range per command using either a number, symbolic name, numeric range, or a symbolic range. Ranges are indicated with a hyphen (-), but without any spaces.

Symbolic names (with the numeric value after) in high to low priority order are: emerg (0), alert (1), crit (2), err (3), warning (4), notice (5), info (6), and debug (7).

### Default Setting

None

### Command Mode

loggingfilter

### Syntax

```
[no] level <level_str>
```

The priority/severity of the messages to filter

| Parameter | Type | Description  |
|-----------|------|--|
| level_str | Word | Specify the level as either a number, symbolic name, numeric range, or a symbolic range. Ranges are indicated with a hyphen (-), but without any spaces. Symbolic names (with the numeric value after) in high to low priority order are: emerg (0), alert (1), crit (2), err (3), warning (4), notice (5), info (6), and debug (7). |

---

## logging server

### Use

Configure a name for a remote logging server to send logging data to. For logging to start, you must set up one or more filters, attach them, and set the admin status to online.

### Default Setting

None

### Command Mode

config



## Syntax

```
[no] logging server <server_name>
```

Configure logging to a remote logging server

| Parameter   | Type | Description                      |
|-------------|------|----------------------------------|
| server_name | Word | Configure a name for the server. |

## Related

REST API Reference - [syslog](#)

---

## admin-status

### Use

Enable or disable logging to this remote server.

### Default Setting

Offline

### Command Mode

loggingserver

### Syntax

```
[no] admin-status offline
```

Disable logging to this remote server

```
[no] admin-status online
```

Enable logging to this remote server

```
no admin-status
```

Remove the configured admin status

---

## attach

### Use

Attach a filter to this remote logging server. If you attach multiple filters to the same server, the system logs all levels included in the filters.

**Default Setting**

None

**Command Mode**

loggingserver

**Syntax**

`[no] attach filter <filter_name>`

Configure the filter to filter messages to log

| Parameter   | Type | Description                   |
|-------------|------|-------------------------------|
| filter_name | Word | Name of the configured filter |

---

## ip

**Use**

Configure the IP address of this remote logging server.

**Default Setting**

None

**Command Mode**

loggingserver

**Syntax**

`[no] ip <addr>`

Configure the IP address of this server

`[no] ip`

Remove the configured the IP address of this server

| Parameter | Type | Description |
|-----------|------|-------------|
|-----------|------|-------------|

|      |        |                                   |
|------|--------|-----------------------------------|
| addr | IPAddr | IP address for the remote server. |
|------|--------|-----------------------------------|

---

## port

### Use

Configure a different port on which this remote logging server receives messages.

### Default Setting

514

### Command Mode

loggingserver

### Syntax

```
[no] port <port_num>
```

Configure the port on which this server receives messages

```
no port
```

Remove the configure the port on this server

| Parameter | Type    | Description                            |
|-----------|---------|--|
| port_num  | Integer | Port number to connect to this server. |

---

## protocol

### Use

Configure the protocol to talk to this remote logging server. You can use either UDP or TCP.

### Default Setting

UDP

### Command Mode

loggingserver

### Syntax

`[no] protocol tcp`

Use TCP to connect to this server

`[no] protocol udp`

Use UDP to connect to this server

`no protocol`

Remove the configured protocol for this server

---

## No Command (Config Mode)

1. [Overview](#)
2. [Objects That Can Have a Base](#)
3. [Objects That Cannot Have a Base](#)
  1. [Commands That Can Have a Single Value](#)
  2. [Commands That Can Have Multiple Values](#)

---

## Overview

In the CLI, most config command sets contain a 'no' command. Depending on the nature of the object, the no command can apply to different configuration. Generally speaking, it negates or removes the specified command or item.

---

## Objects That Can Have a Base

For objects that can have a base, use `no` to remove a direct setting from the object. The object will then inherit that setting from its base. If the object does not have a base or that setting is not configured in the base, the setting reverts to its default.

### Examples

```
LROS(config-rserver:rs-01)# no attach health-monitor <hm_name>
```

This command will remove the specified health monitor from the real server. Any health monitors attached to the base used by the real server will remain active, as will any other health monitors attached directly to the real server.

```
LROS(config-rserver:rs-01)# admin-status offline
```

This command takes the real server offline, overriding the admin-status online setting configured for its base. When you want the real server to inherit its admin status from its base again, enter the following commands:

```
LROS(config)# real-server rs-01
```

```
LROS(config-rserver:rs-01)# no admin-status offline
```

This ensures that the admin status is not set locally on the real server, but that it inherits its setting from the base.

### Command Mode

config

### Syntax

```
no <command> <value_to_remove>
```

---

## Objects That Cannot Have a Base

---

### Commands That Can Have a Single Value

For objects that cannot have a base and commands that can have a single value, the no form of the command removes that value and returns the object back to its default.

#### Example

- **no description <desc>**—Any object that can have a description, such as an interface, can have only one description, therefore, this command removes the description specified and returns the object to its default.
- **no attach ssl profile <profile\_name>**—A REST server can have only one SSL profile attached, therefore, this command removes the SSL profile specified and returns the SSL profile setting to its default.

### Command Mode

config

### Syntax

```
no <command> <value_to_remove>
```

---

### Commands That Can Have Multiple Values

For objects that cannot have a base and commands that can have multiple values, the no form of the command removes the specified value.

#### Examples

- **no real-server <name>**—Any object that can have a name, such as a real server or virtual server, can have more than one name, therefore, this command removes the real server specified, but does not affect other real servers you have created.

- **no ip address <addr>**—Real servers, interfaces, and other objects can have more than one IP address assigned to them, therefore, this command removes the specified IP address, but does not affect any other IP addresses assigned to the object.
- **no hostname <name>**—Virtual servers can have more than one hostname assigned to them, therefore, this command removes the specified hostname, but does not affect any other hostnames assigned to it.

### **Command Mode**

config

### **Syntax**

**no <command> <value\_to\_remove>**

---

## npm Mode Commands

1. [npm](#)
  1. [attach](#)
  2. [url](#)

---

## npm

Configure npm registry options. For information about installing Node Package Modules, see [Scripting Mode Commands](#).

### Use

Use to configure options for the F5<sup>®</sup> LineRate Scripting npm, which is a package manager similar to the one provided for the Node.js platform.

The registry option lets you create one or more custom registries from which you can install Node Packaged Modules. If the registry requires secure access, you can attach a certificate to the registry.



**Note:** If you enable a Point<sup>™</sup> Load Balancer license, you can configure npm registries, but any configured scripts will not run. If you later upgrade to a Precision<sup>™</sup> Load Balancer license, all configured scripts with valid source and admin status set to online will start.

---

### Default Setting

None

### Command Mode

config

### Syntax

```
[no] npm registry <reg_name>
```

Create or manage npm registries.



| Parameter | Type | Description                                   |
|-----------|------|---|
| reg_name  | Word | Name of the npm registry to create or manage. |

## Related

REST API Reference - [npm](#)

CLI Reference - [Show Running Config Commands](#)

CLI Reference - [Scripting Mode Commands](#)

---

## attach

Attach objects, such as a certificate bundle, to the npm registry.

### Use

Use to attach a certificate to the secure location of a custom npm registry. You must first configure certificates to attach.

F5<sup>®</sup> LineRate<sup>®</sup> comes with a default system root certificate bundle for general system use. By default, all scripts and npm registries use the default system root certificate bundle.

If you need to customize the certificates, locate the certificates you want to include (create a file or be prepared to copy and paste them inline), configure a new certificate bundle in F5<sup>®</sup> LineRate<sup>®</sup>, then attach the certificate bundle. The attached certificate bundle acts as the CA root certificate for the script or npm registry.

### Default Setting

None

### Command Mode

config-npm-registry

### Syntax

(Deprecated; use `certificate bundle` below) `attach certificate <cert_name>`

Attach or replace the certificate for the npm registry.

`no attach certificate <cert_name>`

Remove an attached certificate from the npm registry.

**[no] attach certificate bundle**

Attach or replace a certificate bundle for the npm registry. The attached certificate bundle acts as the CA root certificate bundle. If no bundle is attached, default CA system root certificate bundle is used.

**[no] attach certificate bundle <bundle\_name>**

Attach or replace a certificate bundle to the npm registry. The attached certificate bundle acts as the CA root certificate bundle. If no bundle is attached, default CA system root certificate bundle is used.

| Parameter   | Type | Description                             |
|-------------|------|---|
| bundle_name | Word | Name of a certificate bundle to attach. |
| cert_name   | Word | Name of the certificate to attach.      |

## Related

CLI Reference - [Certificate Mode Commands](#)

---

## url

Specify the URL of a custom npm registry.

### Use

Use to specify the URL of a custom npm registry to use for installing Node Packaged Modules.

### Default Setting

None

### Command Mode

config-npm-registry

### Syntax

**[no] url <url\_str>**

Specify the URL of the npm registry

| Parameter | Type | Description |
|-----------|------|-------------|
|-----------|------|-------------|

|         |        |  |
|---------|--------|--|
| url_str | String | URL string. Protect URLs with quotes (for example, " <a href="http://registry.npmjs.org">http://registry.npmjs.org</a> "). |
|---------|--------|--|

---

## NTP Mode Commands (config)

1. [ntp server](#)

---

### ntp server

#### Use

Use to set an IP address of a network time protocol server (NTP) to use to control the system time. You can set up more than one NTP server.

After configuring an NTP server for the first time, we recommend using the [ntp sync](#) command or `/exec/ntp/sync_node` to force an NTP update. Forcing the update ensures that there are no drift issues between the system time and NTP server time. so that NTP can make proper time updates.

#### Default Setting

None

#### Command Mode

config

#### Syntax

```
ntp server <addr>
```

Sets the IP address of the NTP server to use

| Parameter | Type    | Description               |
|-----------|---------|---------------------------|
| addr      | IPAddrI | IP address of NTP server. |

#### Related

REST API Reference - [ntp](#)



## Phone Home Mode Commands

1. [phone-home](#)
  1. [accept-terms](#)
  2. [userid](#)

### phone-home

Settings for configuring Starter Edition licensing and sending phone home data.

#### Use

The phone home feature allows F5<sup>®</sup> to maintain and improve F5<sup>®</sup> LineRate<sup>®</sup> by gathering usage data including, but not limited to, URL addresses, usage, and configuration information. It is required to activate some license types.

To enable phone home, you will need your F5 username and password, which you created when you downloaded the installation file or obtained a license. Also, the system must be able to connect to the Internet so that it can phone home.

The phone home feature allows us to maintain and improve F5<sup>®</sup> LineRate<sup>®</sup> via the reporting of usage data. These data include, but are not limited to, URLs, usage statistics, and configuration information (additional details below). Phone home service is enabled upon activation of certain license types. As successful phone home uploads are required to activate these licenses, you must [configure your F5<sup>®</sup> username and password](#) prior to, or at the time of, license activation.

Phone home sends the following data to F5 once a week:

| Data Sent   | Data collection frequency | Purpose   |
|---|---------------------------|---|
| Core files  | As they occur             | To proactively diagnose errors.                       |
| Output of <code>show tech-support detailed</code> | Hourly                    | To provide information about configuration and usage. |
| System logs (all files in /var/log/)              | Hourly                    | To proactively diagnose errors.                       |

| Data Sent  | Data collection frequency  | Purpose                                     |
|--|--|---|
| Script events (create, remove, online, offline, run-time errors, inline script code) | As they occur, written to disk hourly (or when the amount collected exceeds a threshold) | To proactively diagnose errors.             |
| Per-script statistics  | Every 30 minutes   | To see how much scripting is being used.    |
| On-disk scripts and dependencies (contents of /home/linerate/data/scripting/)        | Every 4 hours  | To proactively diagnose errors.             |
| username.txt file (contains configured phone home username)                          | With each upload   | To identify the configured phone home user. |



**Note:** The phone home feature makes an effort to not include sensitive data like passwords, SSL private keys, and SNMP community strings from the system configuration in the data sent to F5<sup>®</sup>. However, sensitive data in script configuration, on-disk scripts, system logs, and core files cannot be redacted.

### Default Setting

None

### Command Mode

config

### Syntax

[no] `phone-home`

Settings for phone home

### Related Commands

REST API Reference - [phoneHome](#)

---

## accept-terms

### Use

For Amazon EC2, when configuring phone home, you must use this command to accept the phone home terms. When you enter phone-home mode or show phone-home status, the following message displays only for Amazon EC2 users until you agree:

WARNING: Phone-home will gather system usage information and send to F5 Networks. Details on the information collected can be found at <http://docs.lineratesystems.com/AwsPhoneHomeTerms>. To complete phone-home configuration set a username and password and accept phone-home terms.

### Default Setting

None

### Command Mode

config-phone-home

### Syntax

```
accept-terms "I AGREE"
```

Accept licensing terms (only applies to Amazon EC2)

---

## userid

Configure F5 username and password.

### Use

Use to configure the F5 username and password, which you created when you downloaded the installation file, for the Starter Edition license and to send phone home data.

Normally, you should use the clear form of the password, and the system encrypts the password. You can see the encrypted password the following ways:

- CLI command—**show run**
- REST API—/config/phonehome/ihealth/password

Use the encrypted form of the password only when you need to use an existing password on another system. You can copy the encrypted password from the **show run** output or from the /status/config/running node, then paste it into the encrypted form of the command on another system.

### Default Setting

None

### Command Mode

config-phone-home

## Syntax

```
[no] userid <username> secret clear <password>
```

Specifies an unencrypted password will follow

```
[no] userid <username> secret encrypted <password>
```

Specifies an encrypted password will follow

| Parameter | Type   | Description  |
|-----------|--------|--|
| password  | String | The unencrypted (cleartext) or previously encrypted F5 account password. |
| username  | String | F5 username.   |

## Examples

Set the F5Account password to linerate:

```
username F5Account secret clear "linerate"
```

Set the F5Account password to a previously encrypted password by copying the existing encrypted password:

```
username F5Account secret encrypted "$2a$04$aM/tL9/  
37RckSULEU.LkaMjhsK53ciAiWuljp6LC7K"
```



---

## Proxy Mode Commands

1. [proxy max-client-conns](#)
2. [proxy processes](#)

---

### proxy max-client-conns

#### Use

Every connection that the F5<sup>®</sup> LineRate<sup>®</sup> accepts consumes some system memory while it is being processed. The amount of memory is variable and affected by factors such as script processing, SSL offload and key size, and network conditions. If all memory on the system is exhausted, the system may terminate a proxy process to free up memory (an "out-of-memory kill"), which disrupts all traffic through that process.

We recommend correcting this situation by adding more memory to the system, dividing the load among more systems, or improving the memory efficiency of scripts. However, you can adjust this setting as a temporary solution, after consultation with technical support.

If your system experiences out-of-memory kills, you can configure this setting to allow fewer total client connections. This lessens the memory that is consumed, which prevents out-of-memory kills, but it also lessens the total number of clients that can be served at one time. When clients in excess of this limit attempt to connect, they are discarded with a TCP Reset. Many clients report this as "Connection Reset by Peer."

#### Default Setting

0 (disabled; no limit)

#### Command Mode

configure

#### Syntax

```
[no] proxy max-client-conns <conns>
```

Set the maximum number of simultaneous client connections

```
no proxy max-client-conns
```

Remove the maximum number of simultaneous client connections

| Parameter | Type    | Description                                       |
|-----------|---------|---|
| conns     | Integer | Maximum number of simultaneous client connections |

## Related

REST API Reference - [maxClientConns](#)

---

# proxy processes

## Use

Use to reduce the total number of processes dedicated to proxying traffic.

The default "auto" setting allocates the optimal number of processes. The system ignores commands to increase the number of proxy processes beyond the auto setting. Normally, you want to leave the default setting (auto), unless directed to change it by your sales engineer or technical support. Reducing the number of proxy processes may aid in script debugging or leave available CPU resources for management tasks.

The proxy processes are listed as "lb\_http" in the output of the `bash top -HS` or `bash ps aux` command. There is always one extra lb\_http process running for management.

## Default Setting

auto

## Command Mode

configure

## Syntax

```
[no] proxy processes <procs>
```

Setting the number of processes used for the proxy

```
[no] proxy processes auto
```

Allow the system to choose how many proxy processes to run

## no proxy processes

Remove the manually configured number of processes used for the proxy

| Parameter | Type    | Description                                 |
|-----------|---------|---|
| procs     | Integer | Number of proxy processes to run per system |

## Related

REST API Reference - [processes](#)

---

## Real Server Mode Commands

1. [real-server](#)
  1. [admin-status](#)
  2. [attach](#)
  3. [description](#)
  4. [ip address](#)
  5. [max-connections](#)
  6. [service http](#)
    1. [is-proxy](#)
    2. [keepalive-timeout](#)
    3. [max-in-flight](#)
    4. [request-idle-timeout](#)
    5. [request-rate-limit](#)
    6. [response-idle-timeout](#)
    7. [response-timeout](#)
    8. [tunnel idle-timeout](#)
  7. [service tcp](#)
    1. [data-idle-timeout](#)
2. [base](#)
3. [group](#)
  1. [member](#)
  2. [members](#)

Use the following commands to configure real servers. For an example real server configuration, see [Configuring Real Servers](#).

---

## real-server

Create or modify a real server for load balancing.

### Use

Real servers represent a service, for example a web server, that the load balancer (reverse proxy) is distributing the client requests to. Each load balancer requires at least one real server. The IP address and port for the real server must match the IP address and port of the service on the server or proxy server the real server talks to.

You can create multiple real servers, for example, for different application types, hardware capabilities (such as CPU or memory), or security settings (such as SSL).

We also recommend creating one or more real server bases to make configuring real servers more consistent. See [base](#).

## Default Setting

By default, no real servers exist.

When you create a real server, the default settings are:

- admin-status—offline
- attach—nothing attached
- base—none
- description—none
- ip address—none
- service—service is set to http

We recommend giving each real server a meaningful name, based on its use. When naming real servers, also consider how you want to group them and use names that facilitate grouping using simple regular expressions. For example, naming real servers as rs-ssl1, rs-ssl2, and so on, permits the use of a simple regular expression (rs-ssl.\*) to add the real servers to a group.

For more information, see:

CLI Reference - [group](#) and [members](#)

REST API Reference - [realServerGroup](#) and [memberRegex](#)

## Command Mode

config

### Syntax

In one command, you can set the real server name, IP address, port, base, and group, as shown in the syntax examples.

```
[no] real-server <real_server_name>
```

Create or modify a real server.

```
[no] real-server <real_server_name> ip <addr> <port>
```

Create or modify a real server and assign it an IP address and port.

```
[no] real-server <real_server_name> ip <addr> <port> base <base_name_inherit>
```

Create or modify a real server, assign it an IP address and port, and set the base of the real server.

```
[no] real-server base <base_name>
```

Create or modify a real server base.

```
no base
```

Remove all bases from the real server.

| Parameter         | Type    | Description   |
|-------------------|---------|---|
| addr              | IPAddr  | IPv4 or IPv6 address for the real server. See <a href="#">IP Address Notation</a> . |
| base_name         | Word    | Name of the base to create or modify. See <a href="#">base</a> .                    |
| base_name_inherit | Word    | Base from which this real server should inherit. See <a href="#">base</a> .         |
| port              | Integer | Port number to connect to the real server   |
| real_server_name  | Word    | Name of the real server   |

## Related

REST API Reference - [realServer](#)

---

## admin-status

Bring an object, such as a health monitor, real server, or virtual IP, online or offline. After you create an object, you must bring it online.

### Use

You typically set the offline status only when you want to disable the object or block connections to the web server during maintenance or system reconfiguration.

### Default Setting

offline

### Command Mode

config

## Syntax

`admin-status offline`

Bring the object offline

`admin-status online`

Bring the object online

`no admin-status`

Remove the directly configured admin status

---

## attach

Attach an object to the real server.

### Use

Use to attach an object, such as a health monitor, NAT profile, SSL profile, or TCP options group, to the current real server.

### Default Setting

None

### Command Mode

config

## Syntax

`[no] attach health-monitor <hm_name>`

Attach a health monitor to the current real server. You can attach multiple health monitors identified by unique names.

`[no] attach nat profile builtin client-source-address`

Attach and enable a built-in NAT profile that causes the proxy to use the client's address to establish a connection to the current real server. The client-source-address is the only available NAT profile.

---



For an active/active configuration (as described in [this example](#)), you cannot use the client-source-address NAT profile. Using this NAT profile would not permit the real server to know which

---

---

F5® LineRate® system to send traffic back to, because the real server would only know the client's IP address not the IP address of the F5® LineRate® system.

---

`[no] attach ssl profile <ssl_profile_name>`

Attach or replace the SSL profile for the current real server. Only one ssl profile can be attached to a real server.

`[no] attach tcp-options-group <tcp_options>`

Attach or replace the TCP options group for connections to the current real server.

| Parameter        | Type | Description   |
|------------------|------|---|
| hm_name          | Word | Name of the health monitor to attach. See <a href="#">Health Monitor Mode Commands</a> and <a href="#">Configuring a Health Monitor</a> . |
| ssl_profile_name | Word | Name of the SSL profile to attach. See <a href="#">Configuring SSL</a> .  |
| tcp_options      | Word | TCP options group name  |

---

## description

Create a description for the real server.

### Use

Use to create a description of the real server use and any other information.

### Default Setting

None

### Command Mode

config

### Syntax

`description <desc>`



Description for the real server

`no description`

Remove the description

| Parameter | Type   | Description  |
|-----------|--------|--|
| desc      | String | Description string. Enter a maximum of 255 characters. |

---

## ip address

Set the IP address for the real server.

### Use

Use to set the IP address and port for the real server. The IP address must match the IP address and port of the server or proxy server the real server talks to.

### Default Setting

None

### Command Mode

config

### Syntax

`[no] ip address <addr> <port>`

IPv4 or IPv6 address for the real server

`no ip`

Remove the configured IP address

| Parameter | Type   | Description                              |
|-----------|--------|--|
| addr      | IPAddr | IPv4 or IPv6 address for the real server |

|      |         |   |
|------|---------|---|
| port | Integer | Port number to connect to the real server |
|------|---------|---|



Changing a Real Server IP address will cause the current connections to be terminated. Connections will also be terminated if the Real Server address/port is reconfigured.

---

## max-connections

Define the maximum number of simultaneous connections to the current real server.

### Use

Set this to the maximum number of connections the service running on a server can handle.

### Default Setting

0 (this default setting results in permitting up to 64,511 connections)

### Command Mode

config

### Syntax

```
[no] max-connections <max>
```

Maximum number of connections to the current real server

```
no max-connections
```

Remove the directly configured maximum number of connections to the current real server

| Parameter | Type    | Description           |
|-----------|---------|-----------------------|
| max       | Integer | Number of connections |

---

## service http

Configure HTTP as the service type for the real server.

## Use

Sets the current real server to be compatible with layer 7 load balancing, for web use. Use this for web servers that are using HTTP. The service setting on a real server must match the service setting on any virtual server to which the real server is attached. Use for HTTPS as well.

## Command Mode

config

## Default Setting

Service default is http.

## Syntax

```
service http
```

---

## is-proxy

Indicate if the real server is a proxy server.

## Use

Use this only when the real server is talking to a proxy server rather than an actual web server.

## Command Mode

config

## Default Setting

Disabled

## Syntax

```
[no] is-proxy
```

Indicate if the real server is an HTTP proxy server

## Related Commands

[tunnel timeout](#)

---

## keepalive-timeout

Close the real server TCP connection if there is no HTTP activity in this amount of time.

### Use

If there are no active HTTP transactions (that is, no active requests or responses) to a server for the specified time (in seconds), the system closes the TCP connection to the server, reclaiming resources. This can help avoid problems that some HTTP servers have when connections are kept open indefinitely.

Setting this to a value of 0 disables the timeout, which directs the system not to close server TCP connections due to this timeout.

### Command Mode

config

### Default Setting

0 (disabled)

### Syntax

```
[no] keepalive-timeout <timeout>
```

Close TCP connection if there is no HTTP activity in this amount of time

```
no keepalive-timeout
```

Remove the configured keepalive timeout

| Parameter | Type | Description                           |
|-----------|------|---------------------------------------|
| timeout   | Real | Number of seconds (can be fractional) |

---

## max-in-flight

Maximum number of requests that can be pending on one HTTP connection at a time.

### Use

The default of 1 lets the system send only one request at a time on a connection. The system waits for the web server to send the response before sending the next request. The default works in many configurations, especially when the web server has low latency.

If you set this to more than 1, the system can send the specified number of requests to the web server on a single connection, without waiting for the response to each request. Use a higher number when the web server has high latency. This should not exceed the pipeline depth setting of the web server.

### Command Mode

config

### Default Setting

1

### Syntax

```
[no] max-in-flight <requests>
```

Maximum number of requests that can be pending on one HTTP connection at a time

```
no max-in-flight
```

Remove the directly configured max in flight

| Parameter | Type    | Description        |
|-----------|---------|--------------------|
| requests  | Integer | Number of requests |

---

## request-idle-timeout

Configure the number of seconds to wait to receive any part of a request before closing the connection.

### Use

The system closes the connection if it takes longer than the specified time (in seconds) to receive any part of the request from the client.

Consider the size of a typical client request as well as the user environment to set this value. For example, an application where users upload photos or HD videos using mobile devices would need a longer timeout than simple web pages due to mobile bandwidth and device processing limitations.

### Command Mode

config

### Default Setting

0 (disabled)

### Syntax

```
[no] request-idle-timeout <timeout>
```

Number of seconds to wait for new request data before closing the connection

```
no request-idle-timeout
```

Remove the directly configured request idle timeout

| Parameter | Type | Description                           |
|-----------|------|---------------------------------------|
| timeout   | Real | Number of seconds (can be fractional) |

---

## request-rate-limit

Set the real server rate limit.

### Use

Use to set the number of HTTP requests per second to send to the real server. Consider your traffic patterns and the capabilities of all of the servers this real server handles.

Use the burst size to set the maximum number of HTTP requests the servers can handle in a burst above the rate limit. This value may be no less than 2% of the rate limit. By default, the burst size is the same as the request rate limit you configure. For most situations, this works well. Change this setting only if your requests tend to come in bursts.

### Default Setting

0 (no limit)

### Command Mode

config-rserver-http

### Syntax

```
[no] request-rate-limit <limit>
```

Set the real server rate limit

```
no request-rate-limit
```

Remove the directly configured rate limit

```
[no] request-rate-limit <limit> burst-size <burst>
```

Set the maximum burst size (default is the rate limit)

| Parameter | Type    | Description  |
|-----------|---------|--|
| burst     | Integer | Maximum number of requests handled in a burst above the rate limit. This value may be no less than 2% of the rate limit. |
| limit     | Integer | Limit in requests per second   |

---

## response-idle-timeout

Configure the number of seconds to wait for new response data before closing the connection.

### Use

The system closes the connection if, after transmitting the request to the server, it takes longer than the specified time (in seconds) either to receive any part of the response from the HTTP server or to transmit any part of the response to the client.

Consider the size of a typical response for your application as well as the user environment to set this value. For example, an application where users download HD videos using mobile devices would need a longer timeout than simple web pages due to mobile bandwidth and device processing limitations.

### Command Mode

```
config
```

### Default Setting

```
0 (disabled)
```

### Syntax

```
[no] response-idle-timeout <timeout>
```

Number of seconds to wait for new response data before closing the connection

```
no response-idle-timeout
```

Remove the directly configured response idle timeout

| Parameter | Type | Description                           |
|-----------|------|---------------------------------------|
| timeout   | Real | Number of seconds (can be fractional) |

---

## response-timeout

Configure the number of seconds to wait for the server to respond to a request.

### Use

The system sends an HTTP 504 error response to the client and closes the connection if the HTTP server takes longer than the specified time (in seconds) to respond to a request.

Consider the amount of time the web server takes to respond to any request. The response-timeout must always be configured to be higher than the amount of time it takes for any of the web servers to respond to a request.

### Command Mode

config

### Default Setting

0 (disabled)

### Syntax

```
[no] response-timeout <timeout>
```

Number of seconds to wait for the server to respond to a request

```
no response-timeout
```

Remove the directly configured response timeout

| Parameter | Type | Description                           |
|-----------|------|---------------------------------------|
| timeout   | Real | Number of seconds (can be fractional) |



---

## tunnel idle-timeout

Configure HTTP tunnel options.

### Use

The system closes the tunnel connection if it takes longer than the specified time (in seconds) to receive a request from the client.

Use this only when the real server is talking to an HTTP proxy server rather than an actual web server.

### Configuration Mode

config

### Default Setting

0 (disabled)

### Syntax

```
[no] tunnel idle-timeout <timeout>
```

Closes the HTTP tunnel connection if there is no activity in this amount of time

```
no tunnel idle-timeout
```

Remove the directly configured tunnel idle timeout

| Parameter | Type | Description                            |
|-----------|------|--|
| timeout   | Real | Number of seconds (can be fractional). |

### Related Commands

[isproxy](#)

---

## service tcp

Configure TCP as the service type for the real server. The system does load balancing of TCP connections without processing the TCP payload.

### Use

Use this service type for servers that are not using HTTP, for example, an email server.

### Configuration Mode

config

### Default Setting

Service default is http.

### Command Mode

config

### Syntax

```
[no] service tcp
```

Sets the service type to TCP

---

## data-idle-timeout

### Use

The system closes the TCP connection if there is no activity in this amount of time.

### Configuration Mode

config

### Default Setting

0 (disabled)

### Syntax

```
[no] data-idle-timeout <timeout>
```

Closes the TCP connection if there is no activity in this amount of time

```
no data-idle-timeout
```

Remove the directly configured data idle timeout

| Parameter | Type | Description                           |
|-----------|------|---------------------------------------|
| timeout   | Real | Number of seconds (can be fractional) |

---

## base

Inherit parameters from the specified base.

### Use

A "base" in F5® LineRate® is a type of template that allows you to reuse common portions of configuration across multiple objects. Each base can inherit from another base, overriding properties from that base. This lets you create basic configurations that you can reuse and build upon.

Use the `no` command to remove the specified base from the real server. The real server will then use the parameters configured specifically for the real server or the default settings for any parameter that is not configured.

See the Related Commands below for the commands you can use when configuring a real server base.

### Default Setting

None

### Command Mode

config

### Syntax

```
[no] base <base_name>
```

Create or modify a real server base.

```
no base
```

Remove all bases from the real server.

| Parameter | Type | Description                              |
|-----------|------|--|
| base_name | Word | Name of real server base to inherit from |

### Example

See [Creating a Real Server Base](#).

### Related Commands

You can use the following real server commands when configuring a real server base:

[admin-status](#)

[attach](#)

[max-connections](#)

[service](#) - including all settings for HTTP and TCP service

[request-rate-limit](#)

REST API Reference - [realServerBase](#)

---

## group

Create a real server group.

### Use

Use to create real server groups to make configuration more efficient. You can attach a real server group to a virtual server. Group real servers based on those served by the same virtual IP and virtual server.

### Configuration Mode

config

### Default Setting

None

### Syntax

```
[no] real-server group <rs_group_name>
```

Create a real server group.

| Parameter     | Type | Description                              |
|---------------|------|--|
| rs_group_name | Word | Name of the real server group to create. |

### Related

REST API Reference - [realServerGroup](#)

---

## member

Add the named real server to the group.

### Use

Use to add individual real servers to the group.

### Configuration Mode

config

### Default Setting

None

### Syntax

```
[no] member <real_server_name>
```

Add named real server to the group

| Parameter        | Type | Description      |
|------------------|------|------------------|
| real_server_name | Word | Real server name |

---

## members

Specify group membership for multiple real servers.

### Use

Use a regular expression to dynamically add multiple real servers to the group. The system automatically adds real servers to the group, as they are created, if their names match the regular expression.

### Configuration Mode

config

### Default Setting

None

## Syntax

`[no] members by regex <regex>`

Real servers that match regex will be members of the group

| Parameter | Type   | Description  |
|-----------|--------|--|
| regex     | String | Regular expression to use to match real server names (Perl syntax) |

## Examples

`members by regex "^rs.*"`

Adds any real server whose name starts with rs to the group

---

## REST Server Mode Commands

1. [rest-server](#)
  1. [allow from](#)
  2. [allow to](#)
  3. [attach](#)
  4. [logging](#)
  5. [session-idle-timeout](#)

Use the following commands to configure the REST server.

---

### rest-server

Configure access to the REST server.

#### Use

Use to configure the HTTP server on the F5<sup>®</sup> LineRate<sup>®</sup> system for Representational State Transfer (REST) access. Log in to the REST server using the same login and password that you use for the F5<sup>®</sup> LineRate<sup>®</sup> system. By default, connections to the REST server must use SSL port 8443.

F5<sup>®</sup> LineRate Manager, the GUI for F5<sup>®</sup> LineRate<sup>®</sup>, also uses the REST server for access.

The REST server uses the following HTTP verbs: GET, PUT, POST, and DELETE and lets you do the following:

- Configure the system (add, change, or delete configuration)
- Retrieve system configuration
- Retrieve various statistics and counters used to monitor the system

By default, the system configuration permits access to the REST server on any local interface (on port 8443) from any remote host. To connect to the REST server, point your client (custom REST client application or browser) to the REST server's IP address and port to establish a secure HTTP connection.

Before interacting with the REST API, you must do the following:

1. Send a POST request to path /login with the message body containing the username and password credentials. For example, using curl you could authenticate with the following request:

```
curl -k -d "username=admin&password=changeme"
      "https://<server_ip>:<server_port>/login"
```

2. Successful authentication redirects you to the top-level path ("/") and returns a cookie with a unique session ID. Authentication failure redirects you back to the login path (/login).
3. Send the session ID returned as part of the authentication response cookie in all future requests to continue using the session. For example, using curl you could continue using the session as follows:

```
curl -k -i "https://<server_ip>:<server_port>/lrs/api/?op=list" -H "Cookie:
      connect.sid:...."
```

To log out, send a GET request to path /logout. For example, using curl you could log out using the following request:

```
curl -k -i "https://<server_ip>:<server_port>/logout" -H "Cookie: connect.sid:...."
```

## Default Settings

allow from any

allow to any 8443

## Command Mode

config

## Related

[REST API Reference Guide](#)

REST API Reference - [restServer](#)

---

## allow from

Specify remote address information.

### Use

Permit connections from the specified IP addresses to the REST server.

### Default Setting

allow from any

### Command Mode

config

### Syntax



`[no] allow from <v4Addr>`

Remote IPv4 address for a single remote host

`[no] allow from <v4Subnet> <v4Mask>`

Remote IPv4 subnet and mask using subnet and net mask notation

`[no] allow from <v4addrmask>`

Remote IPv4 subnet and mask using CIDR notation

`[no] allow from <v6AddrMask>`

Remote IPv6 subnet and mask using CIDR notation

`[no] allow from any`

Allow access from any remote network

| Parameter  | Type         | Description                                      |
|------------|--------------|--|
| v4Addr     | IPv4Addr     | Remote IPv4 address for a single host            |
| v4AddrMask | IPv4AddrMask | Remote IPv4 subnet and mask using CIDR notation  |
| v4Mask     | IPv4Mask     | Remote IPv4 network mask using net mask notation |
| v4Subnet   | IPv4Subnet   | Remote IPv4 subnet using net mask notation       |
| v6AddrMask | IPv6AddrMask | Remote IPv6 subnet and mask using CIDR notation  |

---

## allow to

Specify local address information.

### Use

Permit connections to the specified IP addresses to access the REST server. The system uses port 8443 for access to the REST server. The IP addresses you specify must be configured on a system interface.

### Default Setting

allow to any 8443

### Command Mode

config

## Syntax

```
[no] allow to <addr>
```

Local address to access

```
[no] allow to <addr> <port>
```

Local address and port to access

```
[no] allow to any
```

Allow connections to all local IP addresses

```
[no] allow to any <port>
```

Allow connections to all local IP addresses using the specified port

| Parameter | Type    | Description                               |
|-----------|---------|---|
| addr      | IPAddr  | IPv4 or IPv6 address on a local interface |
| port      | Integer | TCP port number on which to allow access  |

---

## attach

### Use

Use to attach an SSL profile to the REST server.



**Note:** The REST server is not accessible until an SSL profile is attached to it.

---

### Default Setting

By default, the system creates a key, certificate, and SSL profile, each called self-signed, that you can use to test the SSL function.

The default SSL profile is attached to the REST server.

### Command Mode

```
config
```

### Syntax

```
[no] attach ssl profile <name>
```

Attach or replace the SSL profile for the REST server.

| Parameter | Type | Description                        |
|-----------|------|------------------------------------|
| name      | Word | Name of the SSL profile to attach. |

### Related Commands

[SSL](#)

---

## logging

Enable verbose logging that tracks all REST server commands.

### Use

Without turning on logging, the system only logs logins and logouts. Normally, you do not want to turn on logging. Use logging when debugging REST server issues.

To access the log file, use SSH to access the system, go into bash, and look at the file `/var/log/controller.messages`.

### Default Setting

Disabled

### Command Mode

config

### Syntax

`[no] logging`

---

## session-idle-timeout

Close login session if there is no activity in the specified amount of time.

### Use

The system uses a persistent cookie, so you stay logged in until the specified time elapses or until you log out of the REST server. F5<sup>®</sup> LineRate Manager, the GUI for F5<sup>®</sup> LineRate<sup>®</sup>, also uses the REST server for access, and this timeout also applies to idle time in F5<sup>®</sup> LineRate Manager.

## Default Setting

3600 seconds

## Command Mode

config

## Syntax

```
[no] session-idle-timeout <timeout>
```

Closes login session if there is no activity in this amount of time

```
no session-idle-timeout
```

Removes the configured session idle timeout

| Parameter | Type | Description                            |
|-----------|------|--|
| timeout   | Real | Number of seconds (can be fractional). |

---

## Scheduler Mode Commands

1. [scheduler](#)
  1. [process-class](#)

---

### scheduler

#### Use

Configure operating system process scheduling. Normally, you do not need to change this configuration.

Setting this to **manual** may affect system performance, as well as the response to management input. If you set **scheduler cpu** to **manual**, we recommend that you also configure scheduling for each class of processes using **process-class**, with the assistance of technical support personnel.

#### Default Setting

None

#### Command Mode

config

#### Syntax

```
scheduler cpu auto
```

Allow the system to automatically assign CPU resources to processes

```
scheduler cpu manual
```

Manually assign CPU resources to processes.

#### Related

REST API Reference - [scheduler](#)

---

### process-class

#### Use

Configure scheduling for a class of processes. If you set `scheduler cpu` to `manual`, we recommend that you also configure scheduling for each class of processes using `process-class`, with the assistance of technical support personnel.

## Default Setting

`cpu auto`

## Command Mode

`schedulercpu`

## Syntax

`[no] process-class clock <cpu_list>`

Process that handles operating system periodic tasks

`no process-class clock`

Remove the configured CPU list from the process that handles operating system periodic tasks

`[no] process-class data <cpu_list>`

Processes that handle the data path

`no process-class data`

Remove the configured CPU list from the processes that handle the data path

`[no] process-class default <cpu_list>`

Includes all processes that are not already manually configured

`no process-class default`

Remove the configured CPU list from default, which includes all processes that are not already manually configured

`[no] process-class health <cpu_list>`

Processes for the health monitor

`no process-class health`

Remove the configured CPU list from the processes for the health monitor

`[no] process-class lb-http <cpu_list>`

Processes for the proxy (both HTTP and TCP)

**no process-class lb-http**

Remove the configured CPU list from the processes for the proxy (both HTTP and TCP)

**[no] process-class net-rx <cpu\_list>**

Processes that handle receiving network traffic

**no process-class net-rx**

Remove the configured CPU list from the processes that handle receiving network traffic

**[no] process-class redis-server <cpu\_list>**

Process that provides key/value cache for the F5<sup>®</sup> LineRate Scripting (see <http://redis.io/>)

**no process-class redis-server**

Remove the configured CPU list from the process that provides key/value cache for the F5<sup>®</sup> LineRate Scripting

**[no] process-class regex <regex> <cpu\_list>**

A regular expression that will be matched against process names to select processes included in this class

| Parameter | Type   | Description   |
|-----------|--------|---|
| cpu_list  | String | Comma-separated list of CPU numbers that this process class is allowed to run on. A range can be specified with a dash. Must be enclosed in double quotes. Example: "0,4-7" |
| regex     | String | A regular expression that will be matched against process names to select processes included in this class.   |

---

## Script Mode Commands

1. [script](#)
  1. [admin-status](#)
  2. [attach](#)
  3. [restart-mode](#)
  4. [source](#)
    1. [edit](#)

---

### script

Configure or modify a script.

#### Use

Use to create or change scripts and to configure script settings. For more information about scripts, see the [Scripting Developer's Guide](#) and [Scripting API Reference Guide](#).



**Note:** If you enable a Point™ Load Balancer license, you can configure and edit scripts, but the scripts will not run. If you later upgrade to a Precision™ Load Balancer license, all configured scripts with valid source and admin status set to online will start.

---

#### Default Setting

None

#### Command Mode

config

#### Syntax

```
[no] script <script_name>
```

Configure or modify a script

| Parameter | Type | Description |
|-----------|------|-------------|
|-----------|------|-------------|



|             |      |                     |
|-------------|------|---------------------|
| script_name | Word | Name of the script. |
|-------------|------|---------------------|

## Related

REST API Reference - [script](#)

---

## admin-status

Bring an object, such as a health monitor, real server, or virtual IP, online or offline. After you create an object, you must bring it online.

### Use

You typically set the offline status only when you want to disable the object or block connections to the web server during maintenance or system reconfiguration.

### Default Setting

offline

### Command Mode

config

### Syntax

```
admin-status offline
```

Bring the object offline

```
admin-status online
```

Bring the object online

```
no admin-status
```

Remove the directly configured admin status

---

## attach

### Use

Use to attach objects, such as a certificate bundle, to a script.

F5<sup>®</sup> LineRate<sup>®</sup> comes with a default system root certificate bundle for general system use. By default, all scripts and npm registries use the default system root certificate bundle.

If you need to customize the certificates, locate the certificates you want to include (create a file or be prepared to copy and paste them inline), configure a new certificate bundle in F5® LineRate®, then attach the certificate bundle. The attached certificate bundle acts as the CA root certificate for the script or npm registry.

### Default Setting

None

### Command Mode

config-script

### Syntax

```
[no] attach certificate bundle
```

Attach or replace a certificate bundle for the script. The attached certificate bundle acts as the CA root certificate bundle. If no bundle is attached, default CA system root certificate bundle is be used.

```
[no] attach certificate bundle <bundle_name>
```

Attach or replace a certificate bundle for the script. The attached certificate bundle acts as the CA root certificate bundle. If no bundle is attached, default CA system root certificate bundle is be used.

| Parameter   | Type | Description                            |
|-------------|------|--|
| bundle_name | Word | Name of a certificate bundle to attach |

### Related

CLI Reference - [Certificate Mode Commands](#)

---

## restart-mode

Set script restart mode.

### Use

Use to set the script restart mode. This setting defines the restart behavior when a script encounters unrecoverable errors:

- auto (default)—Script automatically restarts on unrecoverable errors.
- manual—Script does not restart automatically on unrecoverable errors. To restart in manual mode, set the admin-state to offline and then online.

## Default Setting

auto

## Command Mode

config-script

## Syntax

```
[no] restart-mode auto
```

Set script to automatically restart on unrecoverable errors.

```
[no] restart-mode manual
```

Set script to not restart automatically on unrecoverable errors. To restart in manual mode, set the admin-state to off and then on.

---

## source

Specify JavaScript source for the script.

## Use

Use to specify JavaScript source for the script:

- inline—Type or copy and paste a script directly into the command line. In the CLI, the maximum length of an inline script is 10,240 characters.
- file—Call a file that contains the script. Recommended for longer scripts of about 20 or more lines.

## Default Setting

None

## Command Mode

config-script

## Syntax

```
source edit
```

Edit an existing script or create a new one using a text editor.

```
source file <file_str>
```

Specify path name to file containing source.

`source inline <end_word>`

Specify source inline.

| Parameter | Type   | Description  |
|-----------|--------|--|
| end_word  | String | Specify end-word string to signal the end of the source. Note: Enter this string on a line by itself at the end of the source block to indicate the end of the JavaScript source code.   |
| file_str  | String | Path to the script file, which can be absolute (for example, "/home/linerate/data/scripting/proxy/myscript.js") or relative to the scripting home directory /home/linerate/data/scripting (for example, "proxy/myscript.js"). Protect path name with quotes. |

---

## edit

Edit an existing script or create a new one using a text editor.

### Use

Use to edit an existing script or create a new script using an editor. You can edit a script directly in F5<sup>®</sup> LineRate<sup>®</sup> and make changes to simple scripts or small changes to running scripts. For larger scripts or in a production environment, we recommend using a version control system to track changes to scripts.

You can edit scripts if they are inline (defined using the `source inline` command) or if they are in a file (`source file`). If a script has not been previously created, using the editor makes it `source inline`.

After you save and exit the editor, the changes are applied: each proxy process stops running the old script and starts running the new script, as if you had configured it using `source inline` or `source file`. If you save a script with a syntax error, the old script is halted, and the new script will fail to run.

The default and only supported editor is pico. In pico, save by pressing `Ctrl-O` and exit by pressing `Ctrl-X`. If you are prompted to save to a particular file name, accept the file name that the editor suggests (in the case of `source inline` this will be a temporary file; for `source file` it will be the existing file name).

The emacs and vim editors are experimental in this release.

The documentation for editors is available from the following:

- **pico (default)** (pico-alpine-2.00\_1): <http://www.washington.edu/alpine/mans.html#pico> or type `Ctrl-G` in pico
- **emacs** (emacs21): [http://www.delorie.com/gnu/docs/emacs/emacs\\_toc.html](http://www.delorie.com/gnu/docs/emacs/emacs_toc.html) or type `Ctrl-h Ctrl-h` in emacs
- **vim** (vim-lite-7.3.669): [http://vimdoc.sourceforge.net/html/doc/usr\\_toc.html](http://vimdoc.sourceforge.net/html/doc/usr_toc.html) or type `:help <cr>` in vim

## Default Setting

pico

## Command Mode

config-script

## Syntax

```
[no] source edit [emacs | vim]
```

Edit the current script using the default editor (pico) or the specified editor.

---

## SNMP Mode Commands

1. [snmp-server](#)
  1. [community](#)
  2. [contact](#)
  3. [enable](#)
  4. [host](#)
  5. [location](#)

---

### snmp-server

#### Use

Use to configure the SNMP server (agent) to permit access to SNMP data.

The MIBs that the system uses are available from the following locations:

- F5<sup>®</sup> LineRate<sup>®</sup>-specific MIBs—/usr/linerate/mibs on any F5<sup>®</sup> LineRate<sup>®</sup> system.
- Standard RFC MIBs—/usr/local/share/snmp/mibs on any F5<sup>®</sup> LineRate<sup>®</sup> system.

For additional information about F5<sup>®</sup> LineRate<sup>®</sup> and SNMP, see [LineRate and SNMP](#).

To view the snmp-server settings, use `show run`.

#### Default Setting

None

#### Command Mode

configure

#### Syntax

```
[no] snmp-server
```

Configure snmp agent options

#### Related

REST API Reference - [snmp](#)

---

## community

### Use

Use to configure the string to permit read-only access to SNMP.

### Default Setting

public

### Command Mode

snmpserver

### Syntax

```
[no] community <comm_str>
```

Configure the community access string

| Parameter | Type | Description                        |
|-----------|------|------------------------------------|
| comm_str  | Word | Specify the community string token |

---

## contact

### Use

Use to configure system contact information for SNMP.

### Default Setting

None

### Command Mode

snmpserver

### Syntax

```
[no] contact <contact_info>
```

Configure the system contact information

```
no contact
```

Remove the configured contact information

| Parameter    | Type   | Description  |
|--------------|--------|--|
| contact_info | String | String that describes the system contact information |

---

## enable

### Use

Use to enable one or more IP addresses on the system for SNMP access. Typically, you use the management IP address.

Use the "all" setting to permit SNMP access on each IP address configured on the system.

### Default Setting

Default port—161

### Command Mode

```
snmpserver
```

### Syntax

```
[no] enable udpv4 <addr>
```

Configure the IPv4/UDP parameters for the SNMP agent

```
[no] enable udpv4 <addr> <port>
```

Configure the SNMP agent to accept UDP connections only on this IPv4 address

```
[no] enable udpv4 all
```

Configure the SNMP agent to accept UDP connections on all IPv4 addresses

```
[no] enable udpv4 all <port>
```

Configure the SNMP agent to accept UDP connections on all IPv4 addresses

```
[no] enable udpv6 <addr>
```

Configure the IPv6/UDP parameters for the SNMP agent

```
[no] enable udpv6 <addr> <port>
```

Configure the SNMP agent to accept UDP connections only on this IPv6 address

```
[no] enable udpv6 all
```



Configure the SNMP agent to accept UDP connections on all IPv6 addresses

```
[no] enable udpv6 all <port>
```

Configure the SNMP agent to accept UDP connections on all IPv6 addresses

| Parameter | Type    | Description   |
|-----------|---------|---|
| addr      | IPAddr  | Configure the SNMP agent to accept UDP connections only on this IP address. |
| port      | Integer | Configure the SNMP agent to accept UDP connections only on this port.       |

---

## host

Recipient of an SNMP trap.

### Use

Use to configure hosts to receive SNMP traps.

The following options are available for notification-type:

- carp
- failover-group
- interface
- real-server

If no notification-type is specified, all notification types are enabled.

### Default Setting

Default port—162

### Command Mode

```
snmpserver
```

### Syntax

```
host <hostname>
```

Use to configure hosts to receive SNMP traps.

```
[no] host community <communitystr>
```

Use to configure the string to permit read-only access to SNMP. The default is public.

```
[no] host ip <ipAddr>
```

Specify the IP address of the host.

```
[no] host notification-type license-manager
```

Deprecated. Send traps for license manager.

`[no] host udp-port <udpport>`

Specify the UDP port to use for sending traps to this host.

| Parameter    | Type    | Description                  |
|--------------|---------|------------------------------|
| communityStr | String  | Community string token.      |
| hostName     | Word    | Name of SNMP trap recipient. |
| ipAddr       | IPAddr  | IP address of the host.      |
| udpPort      | Integer | UDP port                     |

---

## location

### Use

Use to configure information to identify the system's location.

### Default Setting

None

### Command Mode

snmpserver

### Syntax

`[no] location <location_info>`

Configure the system location information

`no location`

Remove the configured location information

| Parameter     | Type   | Description   |
|---------------|--------|---|
| location_info | String | String that describes the system location information |

---

## SSH Mode Commands

1. [ssh](#)
  1. [allow from](#)
  2. [allow to](#)

Use the following commands to configure SSH access to the F5<sup>®</sup> LineRate<sup>®</sup> system.

---

### ssh

Configure options for Secure Shell (SSH) access to the F5<sup>®</sup> LineRate<sup>®</sup> system.

#### Use

SSH provides secure, remote access to the system.

#### Default Settings

allow from any

allow to any

#### Command Mode

config

#### Related

REST API Reference - [ssh](#)

---

### allow from

#### Use

Permit SSH access from the specified IP address or network.

#### Default Setting

allow from any

## Command Mode

Config

### Syntax

```
[no] allow from <v4Addr>
```

Remote IPv4 address for a single remote host

```
[no] allow from <v4Subnet> <v4Mask>
```

Remote IPv4 subnet and mask using subnet and net mask notation

```
[no] allow from <v4addrmask>
```

Remote IPv4 subnet and mask using CIDR notation

```
[no] allow from <v6AddrMask>
```

Remote IPv6 subnet and mask using CIDR notation

```
[no] allow from any
```

Allow access from any remote network

| Parameter  | Type         | Description                                      |
|------------|--------------|--|
| v4Addr     | IPv4Addr     | Remote IPv4 address for a single host            |
| v4AddrMask | IPv4AddrMask | Remote IPv4 subnet and mask using CIDR notation  |
| v4Mask     | IPv4Mask     | Remote IPv4 network mask using net mask notation |
| v4Subnet   | IPv4Subnet   | Remote IPv4 subnet using net mask notation       |
| v6AddrMask | IPv6AddrMask | Remote IPv6 subnet and mask using CIDR notation  |

---

## allow to

### Use

Permit SSH access to the specified IP address on the F5<sup>®</sup> LineRate<sup>®</sup> system.



**Note:** The SSH server listens on the default port, 22, if a port number is not specified in the configuration.

---

If you leave the default allow to any setting, more specific settings (for example, `allow to 192.0.2.1 23`) override the any setting and permit access using the more specific setting. The default allow to any setting continues to work for any IP address on port 22.

## Default Setting

`allow to any`

## Command Mode

Config

## Syntax

`[no] allow to <addr>`

Local address to access

`[no] allow to <addr> <port>`

Local address and port to access

`[no] allow to any`

Allow connections to all local IP addresses

`[no] allow to any <port>`

Allow connections to all local IP addresses using the specified port

| Parameter | Type    | Description                               |
|-----------|---------|---|
| addr      | IPAddr  | IPv4 or IPv6 address on a local interface |
| port      | Integer | TCP port number on which to allow access  |

## SSL Mode Commands

1. [SSL Overview](#)
2. [ssl profile](#)
  1. [attach](#)
  2. [cipher-list](#)
  3. [ecc-curve-list](#)
  4. [protocol-disable-list](#)
  5. [session cache](#)
  6. [session tickets](#)
3. [base](#)

## SSL Overview

Secure Sockets Layer (SSL) and Transport Layer Security (TLS) are closely related technologies that provide communication security over an insecure network, such as the Internet. TLS is a standardized protocol, defined by IETF RFCs, and is the successor to the non-standardized SSL protocol. The F5<sup>®</sup> LineRate<sup>®</sup> software supports both TLS and SSL, for both service type TCP and service type HTTP, but the system and documentation refers to both protocols collectively as "SSL," following the most common industry terminology.

### Use

The F5<sup>®</sup> LineRate<sup>®</sup> software supports two types of SSL connections:

- SSL termination—SSL connection from the client to the F5<sup>®</sup> LineRate<sup>®</sup> load balancer.
- SSL initiation—SSL connection from the F5<sup>®</sup> LineRate<sup>®</sup> load balancer to the web server.

The diagram below shows the two types of SSL.

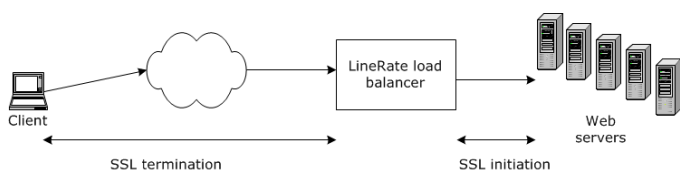

SSL configuration in LineRate

By using the SSL termination feature in F5<sup>®</sup> LineRate<sup>®</sup>, you can move the computationally intensive SSL processing off your web servers and onto F5<sup>®</sup> LineRate<sup>®</sup>, allowing your web servers to concentrate on

performing application tasks. Or, if your application requires greater security on your internal network, you can use SSL initiation together with SSL termination to provide end-to-end SSL security, while still allowing the F5® LineRate® to do full layer 7 load balancing.

For an example SSL configuration, see [Configuring SSL](#).

---

## ssl profile

Create or configure an SSL profile.

### Use

Use to define the security settings you want to use for SSL access. You can use an SSL profile for either termination SSL or initiation SSL or both.

Attaching an SSL profile to a virtual IP configures that virtual IP to always use SSL. The virtual IP will no longer accept connections from clients unless they perform SSL negotiation.

For more information, see [Managing SSL](#).

### Default Setting

By default, the system creates a key, certificate, and SSL profile, each called self-signed, that you can use to test the SSL function.

### Command Mode

Config

### Syntax

`[no] ssl profile <profile name>`  
Creates or manages the specified SSL profile

`[no] ssl profile base <base name>`  
Creates or manages the specified SSL profile base

`no base`  
Removes all configured bases from the SSL profile

| Parameter    | Type | Description                                      |
|--------------|------|--|
| base_name    | Word | Name of the SSL profile base to create or manage |
| profile_name | Word | Name of the SSL profile to create or manage      |

## Related Commands

[virtual-ip](#)

REST API Reference - [ssl](#)

---

## attach

Attaches objects to the SSL profile.

### Use

Use to attach an object, such as certificates and keys, to the SSL profile.

The system lets you attach one or more private keys, primary certificates, individual chain certificates, as well as certificate bundles to an SSL profile. Each chain certificate identifies an intermediate Certificate Authority (CA) that can authenticate a primary certificate for the profile.

A certificate bundle is a single file that contains multiple chain certificates concatenated together. The bundle can include related and unrelated chain certificates. The system automatically looks for the chain certificates that correspond to a primary certificate.

### Default Setting

None

### Command Mode

Config

### Syntax

```
attach chain-certificate <cert_name>
```

Applies to SSL termination and initiation. Add certificates to the certificate chain for this profile. You can associate multiple chain certificates and/or chain certificate bundles with a profile.

```
attach chain-certificate bundle <bundle_name>
```

Applies only to SSL termination. Add a bundle of certificates to the certificate chain for this profile.

```
attach certificate <cert_name>
```

Applies only to SSL termination. A certificate to be presented as the identity of this system during SSL negotiations. A profile can have multiple primary certificates.

```
attach key <key_name>
```

Applies only to SSL termination. The private key that was used to create a primary certificate associated with this profile.



(Deprecated; use `attach certificate` above) `attach primary-certificate <cert_name>`

(Deprecated; use `attach key` above) `attach private-key <key_name>`

| Parameter   | Type | Description  |
|-------------|------|--|
| bundle_name | Word | Name of a certificate bundle to add to the certificate chain       |
| cert_name   | Word | Name of a certificate to be used for identification of this system |
| key_name    | Word | Name of a private key  |

---

## cipher-list

Controls which ciphers this profile will allow.

### Use

Use to set the encryption algorithm, authentication method, and the protocol version the SSL profile uses for SSL connections. The system uses the OpenSSL library. The cipher list applies to both SSL termination and initiation. For SSL termination, the system uses the order set here to control the cipher priority.

To see how the cipher string resolves based on what you enter, use one of the following to look at the ordered cipher list:

- CLI command— `show ssl profile <ssl_profile_name>`
- REST node— `/status/ssl/profile/<name>/cipherNameList`

The Westmere-class processor (required, see [System Requirements](#)) accelerates AES processing, so we recommend placing AES higher in the list to improve performance.

For authentication, the system supports RSA and DSS certificates. For the protocol version, the system supports SSLv2, SSLv3, and TLSv1.



**Note:** If you enable a cipher suite that includes ciphers that F5<sup>®</sup> LineRate<sup>®</sup> does not support, a warning displays telling you the unsupported ciphers have been disabled. The unsupported ciphers are listed below.

---

### Cipher Strings

For the encryption algorithm, the system supports the following cypher strings:

- ALL—All supported cipher suites except the eNULL ciphers which must be explicitly enabled. The cipher suites are reasonably ordered by default.
- COMPLEMENTOFALL—The cipher suites not enabled by ALL, currently being eNULL.
- HIGH—High encryption cipher suites. This currently means those with key lengths larger than 128 bits, and some cipher suites with 128-bit keys.
- MEDIUM—Medium encryption cipher suites, currently some of those using 128-bit encryption.
- LOW—Low encryption cipher suites, currently those using 64- or 56-bit encryption algorithms but excluding export cipher suites.
- EXP, EXPORT, EXPORT40—Export encryption algorithms.
- eNULL, NULL—The NULL ciphers, that is, those offering no encryption. Because these offer no encryption at all and are a security risk they are disabled unless explicitly included.
- aNULL—The cipher suites offering no authentication. This is currently the anonymous DH algorithms. These cipher suites are vulnerable to a "man in the middle" attack, so their use is normally discouraged.
- kRSA, RSA—Cipher suites using RSA key exchange.
- aRSA—Cipher suites using RSA authentication, that is, the certificates carry RSA keys.
- aDSS, DSS—Cipher suites using DSS authentication, that is, the certificates carry DSS keys.
- TLSv1, SSLv3, SSLv2—TLSv1, SSLv3, or SSLv2 cipher suites respectively.
- AES—Cipher suites using AES.
- 3DES—Cipher suites using triple DES.
- DES—Cipher suites using DES (not triple DES).
- ECDHE—Cipher suites using ECDHE.
- RC4—Cipher suites using RC4.
- RC2—Cipher suites using RC2.
- IDEA—Cipher suites using IDEA.
- SEED—Cipher suites using SEED.
- MD5—Cipher suites using MD5.

- SHA1, SHA—Cipher suites using SHA1

### **Cipher List Format**

The cipher list consists of one or more cipher strings separated by colons. Commas or spaces are also acceptable separators but colons are normally used. The actual cipher string can take several different forms:

- It can consist of a single cipher suite such as RC4-SHA.
- It can represent a list of cipher suites containing a certain algorithm or cipher suites of a certain type. For example, SHA1 represents all ciphers suites using the digest algorithm SHA1, and SSLv3 represents all SSL v3 algorithms.
- Lists of cipher suites can be combined in a single cipher string using the + character. This is used as a logical and operation. For example, SHA1+DES represents all cipher suites containing the SHA1 and the DES algorithms.
- Each cipher string can be optionally preceded by the characters !, -, or +.
  - Using !, the ciphers are permanently deleted from the list. The ciphers deleted can never reappear in the list even if they are explicitly stated.
  - Using -, the ciphers are deleted from the list, but some or all of the ciphers can be added again by later options.
  - Using +, the ciphers are moved to the end of the list. This option doesn't add any new ciphers it just moves matching existing ones.
  - If none of these characters is present, the string is just interpreted as a list of ciphers to be appended to the current preference list. If the list includes any ciphers already present they will be ignored, that is, they will not moved to the end of the list.
  - Additionally, the cipher string @STRENGTH can be used at any point to sort the current cipher list in order of encryption algorithm key length.

### **Cipher Suite Names**

The following list is the supported SSL cipher suites names using their OpenSSL format. Some cipher suite names do not include the authentication. In these cases, RSA authentication is used.

The list is in alphabetical order and does reflect any priority ordering.

AECDH-RC4-SHA  
AES128-GCM-SHA256  
AES128-SHA  
AES128-SHA256

AES256-GCM-SHA384  
 AES256-SHA  
 AES256-SHA256  
 DES-CBC3-SHA  
 ECDHE-ECDSA-AES128-SHA  
 ECDHE-ECDSA-AES128-SHA256  
 ECDHE-ECDSA-AES256-SHA  
 ECDHE-ECDSA-AES256-SHA384  
 ECDHE-ECDSA-DES-CBC3-SHA  
 ECDHE-ECDSA-RC4-SHA  
 ECDHE-RSA-RC4-SHA  
 EXP-DES-CBC-SHA  
 EXP-RC4-MD5  
 EXP-RC4-MD5  
 NULL-MD5  
 NULL-SHA  
 NULL-SHA256  
 RC4-MD5  
 RC4-MD5  
 RC4-SHA

### Default Setting

HIGH:!ADH:!SSLv2:!PSK:!ECDH:!kEDH:!SRP:+AES:+3DES

This default means the system uses the cipher suites that are considered to be high security, but not those that authenticate with Diffie–Hellman, not SSLv2 protocol, not preshared keys, not elliptical curve Diffie–Hellman, not ephemeral Diffie–Hellman key exchange, not secure remote password. And of what remains, move those that have AES in them to the end of the list, then move 3DES ciphers to the end. Therefore, the system uses AES ciphers, if possible, then 3DES.

### Command Mode

Config

### Syntax

`cipher-list openssl <list>`  
 Specifies the cipher list in openssl string format

`no cipher-list`  
 Removes the configured cipher list

| Parameter | Type   | Description  |
|-----------|--------|--|
| list      | String | Colon-separated list of cipher strings or cipher suite names |

---

## ecc-curve-list

Control which curve this profile will allow for ECDHE key exchanges.

### Use

Use to change the curve this profile will allow for Ephemeral Elliptic Curve Diffie–Hellman (ECDHE) key exchanges. The curve applies only to SSL termination.

Currently, the system uses only the first curve in the list.



**Note:** F5<sup>®</sup> LineRate<sup>®</sup> supports ECDHE ciphers. To use an ECDHE cipher, you must update the cipher list to remove the default "!ECDH" and to include either "+ECDH" or "+ECDHE" (`cipher-list` CLI subcommand or `/config/ssl/profile/<name>/cipherListOpenSslFormat REST` node). A warning displays telling you that unsupported ciphers have been disabled. The unsupported ciphers are listed in the `cipher-list` section.

---

### Supported ECC Curves

Following are the supported ECC curves:

| Name       | Description                                      |
|------------|--|
| secp112r1  | SECG/WTLS curve over a 112 bit prime field       |
| secp112r2  | SECG curve over a 112 bit prime field            |
| secp128r1  | SECG curve over a 128 bit prime field            |
| secp128r2  | SECG curve over a 128 bit prime field            |
| secp160k1  | SECG curve over a 160 bit prime field            |
| secp160r1  | SECG curve over a 160 bit prime field            |
| secp160r2  | SECG/WTLS curve over a 160 bit prime field       |
| secp192k1  | SECG curve over a 192 bit prime field            |
| secp224k1  | SECG curve over a 224 bit prime field            |
| secp224r1  | NIST/SECG curve over a 224 bit prime field       |
| secp256k1  | SECG curve over a 256 bit prime field            |
| secp384r1  | NIST/SECG curve over a 384 bit prime field       |
| secp521r1  | NIST/SECG curve over a 521 bit prime field       |
| prime192v1 | NIST/X9.62/SECG curve over a 192 bit prime field |
| prime192v2 | X9.62 curve over a 192 bit prime field           |
| prime192v3 | X9.62 curve over a 192 bit prime field           |
| prime239v1 | X9.62 curve over a 239 bit prime field           |
| prime239v2 | X9.62 curve over a 239 bit prime field           |
| prime239v3 | X9.62 curve over a 239 bit prime field           |

prime256v1 X9.62/SECG curve over a 256 bit prime field  
wap-wsg-idm-ecid-wtls6 SECG/WTLS curve over a 112 bit prime field  
wap-wsg-idm-ecid-wtls7 SECG/WTLS curve over a 160 bit prime field  
wap-wsg-idm-ecid-wtls8 WTLS curve over a 112 bit prime field  
wap-wsg-idm-ecid-wtls9 WTLS curve over a 160 bit prime field

**Default Setting**

prime256v1

**Command Mode**

Config

**Syntax**

`ecc-curve-list openssl <ecc_list>`

Specifies the colon-separated list of the elliptical curve names for ECDHE key exchanges in openssl string format

`no ecc-curve-list`

Removes the configured ECC curve list

| Parameter | Type   | Description  |
|-----------|--------|--|
| ecc_list  | String | Colon-separated list of ECC curves in openssl string format for ECDHE key exchanges. |

---

## protocol-disable-list

**Use**

Use to set which SSL protocols are disabled. The protocol disable list applies to both SSL termination and initiation.

To provide maximum security against known security vulnerabilities, SSLv2 and SSLv3 are disabled by default.

F5<sup>®</sup> LineRate<sup>®</sup> supports the following protocols: SSLv2, SSLv3, and TLSv1.

**Default Setting**

SSLv2:SSLv3

## Command Mode

Config

### Syntax

```
protocol-disable-list <protocols>
```

Set the list of disabled SSL protocols

```
protocol-disable-list lros-default
```

Set the list of disabled protocols to the default list

| Parameter | Type   | Description   |
|-----------|--------|---|
| protocols | String | Colon-separated list of SSL protocols to disable. For example: SSLv2:SSLv3:TLSv1. |

---

## session cache

Set session cache memory size.

### Use

Use to improve performance for SSL connections by storing session keys. The system saves and can reuse an SSL session key for client connections. The cached session key lets the system establish the SSL connection to the same client, bypassing the normal SSL handshake process.

This applies to SSL termination only. You set the amount of system RAM you want to use to store session keys. To determine the space needed to use session keys effectively, consider the following:

- The more active clients you have, the more space you need for the keys, which are generally about 2 KiB.
- To be beneficial, the cache must be large enough to store session keys between connections from the same client.
- Consider how many connections per second you expect and how much time you expect between the same client connecting multiple times.

In a failover situation, where the primary system fails over to a secondary system, the session cache is not copied to the secondary system.

You can use both session cache and session tickets at the same time. If the client supports session tickets, the system uses the session ticket. If the client does not support session tickets, the system uses session cache.

### Default Setting

auto, which is 10 MiB

### Command Mode

config

### Syntax

`[no] session cache <size>`  
Configure session cache in bytes

`[no] session cache <size> kibibytes`  
Specified cache size is in kibibytes (system multiples the <size> x 1024)

`[no] session cache <size> mibibytes`  
Specified cache size is in mibibytes (system multiples the <size> x 1024 x 1024)

`session cache auto`  
Enable session caching with automatic cache size

`session cache disable`  
Disable session caching

`no session cache`  
Removes the configured session cache

| Parameter | Type    | Description  |
|-----------|---------|--|
| size      | Integer | Set session caching to the specified size in bytes. Minimum cache size is 20480 bytes. |

---

## session tickets

Enable or disable SSL session tickets.

### Use

Use to improve performance for SSL connections by creating session tickets that the client stores. If the client's browser and operating system support session tickets, the system uses a valid session ticket to establish the SSL connection to the same client, bypassing the normal SSL handshake process.



This applies to SSL termination only.

You can use both session cache and session tickets at the same time. If the client supports session tickets, the system uses the session ticket. If the client does not support session tickets, the system uses session cache.

In a failover situation, where the primary system fails over to a secondary system, the session tickets still work, because the client stores them.

**Default Setting**

Disabled

**Command Mode**

Config

**Syntax**

`session tickets disable`  
Disable session tickets

`session tickets enable`  
Enable session tickets

`no session tickets`  
Removes the configured session tickets

---

## base

Inherit parameters from an SSL profile base.

**Use**

A "base" in F5<sup>®</sup> LineRate<sup>®</sup> is a type of template that allows you to reuse common portions of configuration across multiple objects. Each base can inherit from another base, overriding properties from that base. This lets you create basic configurations that you can reuse and build upon.

See [Working with Bases](#).

Use the no command to remove the specified base from the SSL profile. The SSL profile will then use the parameters configured for any other base it inherits from, specifically for the SSL profile, or the default settings for any parameter that is not configured.

See the Related Commands below for the commands you can use when configuring an SSL profile base.

**Default Setting**

None

## Command Mode

Config

## Syntax

**base** <name>

Inherit parameters from an SSL profile base

| Parameter | Type | Description                                 |
|-----------|------|---|
| name      | Word | Name of an SSL profile base to inherit from |

## Related Commands

[ssl\\_profile](#)

[attach](#)

[cipher-list](#)

[ecc-curve-list](#)

[session cache](#)

[session tickets](#)

---

## System Mode Commands

1. [system kernel-exception](#)
2. [system root-cert-bundle](#)

---

### system kernel-exception

#### Use

Use to configure what the system does with error information if the system kernel has an unrecoverable error. The default is text only.

Configure for full output only when directed by technical support personnel. The full output creates a file the same size as the system memory and significantly slows the system restart.

You can enable both full and text.

#### Default Setting

None

#### Command Mode

config

#### Syntax

```
system kernel-exception dump full
```

Dump entire contents of memory, which will take a long time. Configure for full output only when directed by technical support personnel.

```
system kernel-exception dump text
```

Dump brief textual information representing system state.

```
no system kernel-exception
```

Returns the kernel exception dump to the default, which is text.

#### Related

---

## system root-cert-bundle

### Use

Use to configure the system root certificate bundle.

F5<sup>®</sup> LineRate<sup>®</sup> comes with a default system root certificate bundle for general system use. By default, all scripts and npm registries use the default system root certificate bundle.

If you need to customize the system root certificate bundle, locate the certificates you want to include (create a file or be prepared to copy and paste them inline), configure a new certificate bundle in F5<sup>®</sup> LineRate<sup>®</sup>, then use the `system root-cert-bundle <bundle_name>` command to replace the default system root certificate bundle with your bundle.

When you replace the default system root certificate bundle, F5<sup>®</sup> LineRate<sup>®</sup> retains the default bundle and lets you revert back to the default bundle with `no system root-cert-bundle`.

### Default Setting

None

### Command Mode

config

### Syntax

```
no system root-cert-bundle
```

Remove the system root certificate bundle and revert to the default bundle

```
[no] system root-cert-bundle <bundle_name>
```

Configure the system root certificate bundle

| Parameter   | Type | Description  |
|-------------|------|--|
| bundle_name | Word | Name of the certificate bundle to used as system root certificate bundle |

### Related

CLI Reference Guide - [Certificate Mode Commands](#)

REST API Reference Guide - [rootCertBundle](#)

---

## TCP Mode Commands

1. [tcp-options-group](#)
  1. [nagle-delay](#)

---

### tcp-options-group

#### Use

Use to create or modify a TCP options group. Create a TCP options group only when you want to enable the Nagle algorithm. The Nagle algorithm should be left disabled for most network applications.

#### Default Setting

None

#### Command Mode

config

#### Syntax

```
[no] tcp-options-group <name>
```

Create or modify a TCP options group

| Parameter | Type | Description                    |
|-----------|------|--------------------------------|
| name      | Word | Name of the TCP options group. |

#### Related

REST API Reference - [tcpOptions](#)

---

### nagle-delay

#### Use

Use to enable the Nagle algorithm for TCP sessions. Collects multiple small data writes together to reduce the total number of TCP packets sent on the network. This option is disabled by default and should be left disabled for most network applications.

### **Default Setting**

Disabled

### **Command Mode**

tcpOptions

### **Syntax**

`[no] nagle-delay`

Enables the Nagle algorithm for TCP sessions. Collects multiple small data writes together to reduce the total number of TCP packets sent on the network. This option should be left disabled for most network applications.

---

## User Name Mode Commands

1. [username](#)
  1. [secret](#)
  2. [sshkey](#)
  3. [uid](#)

---

### username

Configure local user authentication

#### Use

Use to configure users who need access to the F5<sup>®</sup> LineRate<sup>®</sup> system. All users have access to all functions. The system tracks user logins and logouts and a few key actions, such as reload.

You can configure user authentication any of the following ways:

- Using a password that you have to enter each time you log in.
- Using SSH key-based authentication, where you configure F5<sup>®</sup> LineRate<sup>®</sup> with the public key and SSH clients that possess the private key are authenticated.

You can configure one password and multiple SSH keys for each user.



**Note:** The default running-config will contain an "admin" user, with a default secret of "changeme". However, in Amazon EC2, the secret is omitted and instead an sshkey named "ec2" is added from the EC2 key pair used to launch the instance. If you are not familiar with using SSH key pairs, see the [AWS documentation](#).

---

#### Default Setting

None

#### Command Mode

configure

#### Syntax

[no] **username** <username>

Specifies the user name

(Deprecated; use the subcommands below) [no] **username** <username> **secret encrypted** <password> [uid <userid>]

Specifies the user name and an encrypted secret; optionally specifies the user ID

(Deprecated; use the subcommands below) [no] **username** <username> **secret clear** <password> [uid <userid>]

---

## secret

### Use

Use to configure or change the password.

If no password is set, then password authentication is disabled.

If you include characters other than letters (upper or lower), digits, dashes, and periods in a password, you must put double quotes around it.

Normally, you should use the clear form of the password, and the system encrypts the password. You can see the encrypted password the following ways:

- CLI command—**show run**
- REST API—/config/users/<user\_name>/authentication/password/hash5

Use the encrypted form of the password only when you need to use an existing password on another system. You can copy the encrypted password from the **show run** output or from the /status/config/running node, then paste it into the encrypted form of the command on another system.

### Default Setting

None.

### Command Mode

configure

### Syntax

[no] **secret clear** <password>

Specifies the user name and an unencrypted secret; The secret is immediately encrypted.



```
[no] secret encrypted <password>
```

Specifies the user name and an encrypted secret.

| Parameter | Type   | Description  |
|-----------|--------|--|
| password  | String | The unencrypted (clear text) or previously encrypted user account secret |

### Examples

Set admin's password to linerate:

```
secret clear "linerate"
```

Set admin's password to the previously encrypted password (changeme) by copying the existing encrypted password:

```
secret encrypted "$2a$04$aM/tL9/37RckSULEU.LkUT.JttOaMjhsK53ciAiWuljp6LC7K"
```

---

## sshkey

### Use

Use to specify the public SSH key to use when accessing the F5<sup>®</sup> LineRate<sup>®</sup> system using SSH.



**Note:** In Amazon EC2, the default running-config will contain an "admin" user with an sshkey named "ec2" from the EC2 key pair used to launch the instance. Use this SSH key pair for initial SSH access to the F5<sup>®</sup> LineRate<sup>®</sup> instance. If you are not familiar with using SSH key pairs, see the [AWS documentation](#).

---

### Default Setting

None

### Command Mode

configure

### Syntax

```
[no] sshkey <key_name> (ssh-rsa|ssh-dsa) <key>
```

Specifies the named public SSH key and type to use for the specified user

```
no sshkey <key_name>
```

Removes the specified key by name

| Parameter | Type   | Description                   |
|-----------|--------|-------------------------------|
| key_name  | String | Name to identify the SSH key. |
| key       | String | Public SSH key.               |

---

## uid

### Use

Use to specify a user ID. If you do not specify a user ID, the system automatically assigns a unique user ID, starting with 2000.

### Default Setting

Unique ID assigned by system if not specified

### Command Mode

configure

### Syntax

```
uid <userid>
```

Specifies the user ID

| Parameter | Type    | Description     |
|-----------|---------|-----------------|
| userid    | Integer | Numeric user ID |

---

## Virtual IP Mode Commands

1. [virtual-ip](#)
  1. [admin-status](#)
  2. [attach](#)
  3. [incoming-queue-length](#)
  4. [ip address](#)
  5. [max-embryonic-conns](#)
  6. [service http](#)
    1. [keepalive-timeout](#)
    2. [max-in-flight](#)
    3. [max-request-header-size](#)
  7. [service tcp](#)
2. [base](#)

Use the following commands to configure virtual IPs.

---

### virtual-ip

Create or modify a virtual IP for reverse proxy (load balancing) or forward proxy.

#### Use

For either a load balancing or forward proxy use case, the system requires at least one virtual IP. The virtual IP is a configuration object that represents the interface that clients connect to. You can create as many virtual IPs as you need. For an overview of how virtual IPs are used in a load balancing use case, see [F5® LineRate® Overview](#).

We recommend giving each virtual IP a meaningful name that helps identify the virtual IP. For example, you might use the application or service type (such as serving similar web content) or security settings (such as SSL) in the name.

Use to set the IP address or IP address range and port for the virtual IP. This designates the IP addresses that the system will accept traffic for.



**Note:** For most reverse proxy configurations, the IP address of each virtual IP must also be configured as an IP address on the data interface. If the IP address of the virtual IP is not also

---

---

configured on a data interface, the system displays the following warning when you set the admin status to online: WARNING: virtual-ip test2 has ARP reply disabled until the IP address is configured on a system interface.

---

You can set either a specific IP address and port or a range of IP addresses for a specific port. The range includes both addresses you specify as the range start and end. A range cannot overlap any other range on the system for the same port.

If a virtual IP has a specific IP assigned to it that falls within the range of another virtual IP, the system sends all traffic to the virtual IP with the specific IP address.

---



**Caution:** When attaching a virtual IP to a forward proxy, the virtual IP must not include any of the system's own IP addresses. For a virtual IP with a single IP address, do not set the virtual IP's IP address to one of the system's own IP addresses. For a virtual IP with a range of addresses, you must ensure that the IP address range does not contain any of the system's own IP addresses. This may mean you need to break the virtual IP into multiple virtual IPs. See [Configuring a range for a virtual IP with forward proxy](#) for more detail and an example.

---

The system handles routed virtual IPs. Even if you set a large range of IP addresses for a virtual IP, the system only sends an ARP reply if an IP address in the range is configured on an interface. However, the system will accept traffic for any IP address in the range.

## Command Mode

config

### Syntax

```
virtual-ip <name>
```

Create or modify a virtual IP for load balancing

```
virtual-ip <name> ip <addr> <port>
```

IPv4 or IPv6 address of interface for client access

```
virtual-ip <name> ip <addr> <port> base <basename>
```

Set the base that the virtual IP will inherit from

```
[no] virtual-ip <name> ip range <startaddr> <endaddr> <port>
```

Set a range of IPv4 or IPv6 addresses for client access

```
[no] virtual-ip <name> ip range <startaddr> <endaddr> <port> base <base_name>
```

Set a range of IPv4 or IPv6 addresses for client access and set the base that the virtual IP will inherit from

```
virtual-ip base <name>
```

Create or modify a virtual IP base for virtual IPs to inherit

```
no base
```

Remove the configured base

| Parameter | Type     | Description  |
|-----------|----------|--|
| addr      | IPAddr   | IPv4 or IPv6 address for interface configured for client access          |
| baseName  | Word     | Name of base that the virtual IP will inherit from                       |
| endaddr   | IPv4Addr | Ending IPv4 or IPv6 address for interface configured for client access   |
| name      | Word     | Name of the virtual IP   |
| port      | Integer  | Port number to connect to on the real server                             |
| startaddr | IPv4Addr | Starting IPv4 or IPv6 address for interface configured for client access |

## Related

REST API Reference - [virtualIP](#)

---

## admin-status

Bring an object, such as a health monitor, real server, or virtual IP, online or offline. After you create an object, you must bring it online.

### Use

You typically set the offline status only when you want to disable the object or block connections to the web server during maintenance or system reconfiguration.

### Default Setting

offline

### Command Mode

config

## Syntax

`admin-status offline`

Bring the object offline

`admin-status online`

Bring the object online

`no admin-status`

Remove the directly configured admin status

---

## attach

Attach an object.

### Use

Use to attach an object, such as an IP filter, SSL profile, or TCP options group , to the current virtual IP.

### Default Setting

None

### Command Mode

config

### Syntax

`[no] attach ip-filter <name>`

Attach or replace the filter used to decide if hosts may connect to this virtual IP.

`[no] attach ssl profile <name>`

Attach or replace the SSL profile for the current virtual IP.

`[no] attach tcp-options-group <name>`

Attach or replace the TCP options group for connections to the current virtual IP.

| Parameter | Type | Description |
|-----------|------|-------------|
|-----------|------|-------------|

|      |      |   |
|------|------|---|
| name | Word | Name of the IP filter, SSL profile, or TCP options group to attach. See <a href="#">Configuring SSL</a> . |
|------|------|---|

---

## incoming-queue-length

Length of the queue for established incoming connections.

### Use

Use to configure how many simultaneous established TCP connections are allowed to wait to be accepted for processing. A shorter queue length will prevent too many connections from waiting to be serviced, by resetting them if the queue is full. This has the effect of reducing the rate that new connections can be established. Determine based on the speed of your system, and the workload it is seeing.

### Default Setting

0, which is the system maximum of 65535

### Command Mode

config

### Syntax

`incoming-queue-length <max>`

Length of the queue for established incoming connections.

`no incoming-queue-length`

Remove the directly configured incoming queue length.

| Parameter | Type    | Description                          |
|-----------|---------|--------------------------------------|
| max       | Integer | Number of items allowed in the queue |

---

## ip address

Use to set the IP address or IP address range and port for the virtual IP. This designates the IP addresses that the system will accept traffic for.

---



**Note:** For most reverse proxy configurations, the IP address of each virtual IP must also be configured as an IP address on the data interface. If the IP address of the virtual IP is not also configured on a data interface, the system displays the following warning when you set the admin status to online: WARNING: virtual-ip test2 has ARP reply disabled until the IP address is configured on a system interface.

---

You can set either a specific IP address and port or a range of IP addresses for a specific port. The range includes both addresses you specify as the range start and end. A range cannot overlap any other range on the system for the same port.

If a virtual IP has a specific IP assigned to it that falls within the range of another virtual IP, the system sends all traffic to the virtual IP with the specific IP address.

---



**Caution:** When attaching a virtual IP to a forward proxy, the virtual IP must not include any of the system's own IP addresses. For a virtual IP with a single IP address, do not set the virtual IP's IP address to one of the system's own IP addresses. For a virtual IP with a range of addresses, you must ensure that the IP address range does not contain any of the system's own IP addresses. This may mean you need to break the virtual IP into multiple virtual IPs. See [Configuring a range for a virtual IP with forward proxy](#) for more detail and an example.

---

The system handles routed virtual IPs. Even if you set a large range of IP addresses for a virtual IP, the system only sends an ARP reply if an IP address in the range is configured on an interface. However, the system will accept traffic for any IP address in the range.

F5<sup>®</sup> LineRate<sup>®</sup> supports both IPv4 and IPv6. You can specify the IP address and subnet mask in any of the following formats:

- 192.0.2.1/24— example of an IPv4 address with a 24-bit subnet mask using CIDR notation.
- 192.0.2.1 255.255.255.0—equivalent to above using net mask notation.
- 2001:DB8::/64—example of an IPv6 address with a 64 bit subnet mask using CIDR notation.

If you need more information about IP addresses and subnet masks, see these sites for more information:

- [http://en.wikipedia.org/wiki/IP\\_address](http://en.wikipedia.org/wiki/IP_address)
- [http://en.wikipedia.org/wiki/CIDR\\_notation](http://en.wikipedia.org/wiki/CIDR_notation)

## Default Setting

None



## Command Mode

config

### Syntax

```
[no] ip address <addr> <port>
```

IPv4 or IPv6 address for the virtual IP

```
[no] ip range <start_addr_v4> <end_addr_v4>  
      <port></end_addr_v4></start_addr_v4>
```

IPv4 address ending the range (inclusive)

```
[no] ip range <start_addr_v6> <end_addr_v6>  
      <port></end_addr_v6></start_addr_v6>
```

IPv6 address ending the range (inclusive)

```
no ip
```

Remove the configured IPv4 or IPv6 settings

| Parameter     | Type     | Description                                 |
|---------------|----------|---|
| addr          | IPv4Addr | Virtual IPv4 address                        |
| end_addr_v4   | IPv4Addr | IPv4 address ending the range (inclusive)   |
| end_addr_v6   | IPv6Addr | IPv6 address ending the range (inclusive)   |
| port          | Integer  | TCP port number on this virtual IP address  |
| start_addr_v4 | IPv4Addr | IPv4 address starting the range (inclusive) |
| start_addr_v6 | IPv6Addr | IPv6 address starting the range (inclusive) |



Changing a Virtual IP address will cause the current connections to be terminated. Connections will also be terminated if the Virtual IP address/port is reconfigured.

---

## max-embryonic-conns

Maximum number of embryonic TCP connections to allow at one time.

### Use

Maximum number of partially established (half-open) connections to allow at one time on the virtual IP. Fewer embryonic connections helps prevent too many connections from starting and exhausting resources. Determine based on the speed of your processor and the number of connections you expect per second.

### Default Setting

0 (disabled)

### Command Mode

config

### Syntax

```
max-embryonic-conns <max>
```

Maximum number of embryonic connections to allow at one time on the virtual IP

```
no max-embryonic-conns
```

Remove the directly configured max embryonic conns

| Parameter | Type    | Description                             |
|-----------|---------|---|
| max       | Integer | Number of embryonic connections allowed |

---

## service http

The nodes below this one configure settings for the HTTP service type.

Set the service type for the virtual IP in the [serviceType](#) node.

### Command Mode

config

### Default Setting

Service default is http.

### Syntax

```
service http
```

---

## keepalive-timeout

Close the client TCP connection if there is no active HTTP request or response in this amount of time.

### Use

HTTP allows for a client to open a TCP connection to a server and send more than one HTTP request through the connection. Many HTTP clients will allow an idle TCP connection to remain open for long periods of time so that it may be used for a future HTTP request. Configuring `keepalive-timeout` directs the system to close TCP connections after they have been idle (i.e. no active HTTP request or response) for the configured amount of time, thus reclaiming system resources.



**Caution:** Correctly configuring this setting is very important to prevent the system from running out of connection resources.

---

The value for this setting should be set relative to the expected maximum number of connections per second that this virtual IP will handle and the maximum number of simultaneous open connections you would like to maintain on this virtual IP. A good estimate for this value can be obtained with the following formula:

$$\text{keepalive timeout} = \text{max simultaneous conns} / (\text{max expected conns per second})$$

### Default Setting

10 seconds

### Command Mode

config

### Syntax

```
keepalive-timeout <timeout>
```

Closes the TCP connection if there is no HTTP activity in this amount of time

```
no keepalive-timeout
```

Remove the directly configured keepalive timeout

| Parameter | Type | Description                           |
|-----------|------|---------------------------------------|
| timeout   | Real | Number of seconds (can be fractional) |

---

## max-in-flight

Maximum number of requests that can be pending on one HTTP connection at a time.

### Use

The default is 1, which lets the virtual IP send only one request at a time from a specific client. The virtual IP waits for the real server to send the response before sending the next request from the client. The default works in many configurations, especially when the web server has low latency.

If you set this to more than 1, the virtual IP can send the specified number of requests to the real server from a specific client, without waiting for the response to each request. Use a higher number when the web server has high latency. This should not exceed the pipeline depth setting of the web server.

### Default Setting

1

### Command Mode

config

### Syntax

```
max-in-flight <max>
```

Number of outstanding requests that can be in process at one time

```
no max-in-flight
```

Remove the directly configured max in flight

| Parameter | Type    | Description        |
|-----------|---------|--------------------|
| max       | Integer | Number of requests |

---

## max-request-header-size

Maximum number of request header bytes to process.

### Use

If the header size exceeds this value, the virtual IP closes the connection. This secures the system's memory.

If your application or environment supports a large number of cookies, you may need to increase this value. A proxy server also can add cookies to the header.

### Default Setting

32 KB

### Command Mode

config

### Syntax

`max-request-header-size <max>`

Maximum number of request header bytes to process

`max-request-header-size unlimited`

Indicates unlimited number of bytes

`no max-request-header-size`

Remove the directly configured max request header size

| Parameter | Type    | Description     |
|-----------|---------|-----------------|
| max       | Integer | Number of bytes |

---

## service tcp

This node is for future use.

Set the service type for the virtual IP in the [serviceType](#) node.

### **Default Setting**

None

### **Command Mode**

config

### **Syntax**

```
service tcp
```

---

## **base**

Inherit parameters from the specified base.

### **Use**

A "base" in F5® LineRate® is a type of template that allows you to reuse common portions of configuration across multiple objects. Each base can inherit from another base, overriding properties from that base. This lets you create basic configurations that you can reuse and build upon.

See [Working with Bases](#).

Use the no command to remove the specified base from the virtual IP. The virtual IP will then use the parameters configured for any other base it inherits from, specifically for the virtual IP, or the default settings for any parameter that is not configured.

See the Related Commands below for the commands you can use when configuring a virtual IP base.

### **Default Setting**

None

### **Command Mode**

config

### **Syntax**

```
[no] base <name>
```

Remove the base from the virtual IP

| Parameter | Type | Description                             |
|-----------|------|---|
| name      | Word | Name of virtual IP base to inherit from |

### Related Commands

[admin-status](#)

[attach](#)

[incoming-queue-length](#)

[max-embryonic-conns](#)

[service http](#)

[service tcp](#)

REST API Reference - [virtualIPBase](#)

---

## Virtual Server Mode Commands

1. [virtual-server](#)
  1. [attach](#)
  2. [description](#)
  3. [ip](#)
  4. [lb-algorithm](#)
  5. [service http](#)
    1. [client-ip-header](#)
    2. [forward-connect-requests](#)
    3. [hostname](#)
    4. [persist](#)
    5. [request-rate-limit](#)
    6. [strip-request-header](#)
    7. [tcp-multiplex](#)
  6. [service tcp](#)
    1. [persist](#)

Use the following commands to configure virtual servers. For an example virtual server configuration, see [Configuring a Virtual Server](#).

---

### virtual-server

Configure a virtual server.

#### Use

Each load balancing (reverse proxy) configuration requires at least one virtual server. The virtual server is a configuration object that acts as a reverse proxy and ties together one or more virtual IPs and real servers. You also set the load balancing algorithm on the virtual server.

We recommend giving each virtual server a meaningful name that helps identify the server use. For example, you might name a virtual server based on the application and the resources that the virtual server is load balancing traffic to (real servers).

#### Default Setting

None



## Command Mode

config

## Syntax

```
virtual-server <name>
```

Create or modify a virtual server for load balancing

| Parameter | Type | Description                |
|-----------|------|----------------------------|
| name      | Word | Name of the virtual server |

## Related

REST API Reference - [virtualServer](#)

---

## attach

Attach an object to the virtual-server.

### Use

Use to attach a virtual IP or real server to this virtual server. You normally attach one virtual IP to a virtual server and attach many real servers to a virtual server.

### Default Setting

None

## Command Mode

config

## Syntax

```
attach real-server <name>
```

Name of a real server to attach to this virtual server

```
attach real-server <name> weight <wt>
```

Specify a weight for this real server. The weight affects how the system load balances when using a weighted load balancing algorithm. The weight assigned to a specific real server overrides the weight assigned to a group the real server is a member of.

`attach real-server group <group_name>`

Name of a real server group whose members will be attached to this virtual server

`attach real-server group <group_name> weight <wt>`

Specify a weight for all real servers in this group. The weight affects how the system load balances real servers in the group when using a weighted load balancing algorithm.

`attach virtual-ip <vip> default`

For service HTTP. Sets the virtual IP as the default for the virtual server and directs the incoming HTTP requests with a hostname that does not match the configured list to this virtual server. Use when you have the same virtual IP attached to more than one virtual server, and you use hostnames with the virtual servers.

| Parameter | Type | Description  |
|-----------|------|--|
| name      | Word | Name of the real server to attach  |
| vip       | Word | Name of a virtual IP to attach   |
| wt        | Real | Weight for this real server used in weighted load balancing algorithms. For example, if you assign a weight of 1 to one real server and 3 to another real server, the load balancer sends three times as many connections to the real server with the weight of 3. |

---

## description

Create a description for the virtual server.

### Use

Use to create a description of the virtual server use and any other information.

### Default Setting

None

### Command Mode

config

## Syntax

`description <desc>`

Description for the virtual server

`no description`

Remove the description

| Parameter | Type   | Description  |
|-----------|--------|--|
| desc      | String | Description string. Enter a maximum of 255 characters. |

---

## ip

Configure DSCP settings.

### Use

Use to configure how F5<sup>®</sup> LineRate<sup>®</sup> populates the Differentiated Services Code Point (DSCP) bits as packets pass through to provide quality of service for IP networks. Use the options to configure where the bits are going to or the specific value to use. For the valid values and more information about DSCP, see [http://en.wikipedia.org/wiki/Differentiated\\_Services\\_Code\\_Point](http://en.wikipedia.org/wiki/Differentiated_Services_Code_Point).

When you enable the copy option, any value that was previously set is changed to 0. Conversely, when you set a value, the copy option is changed to 0, disabling the copy.

### Default Setting

None

### Command Mode

config-vserver

### Syntax

`[no] ip dscp client <value>`

Configure IP packet DSCP settings for flows to the client

`[no] ip dscp client copy`

Copy IP packet DSCP bits from the server to the client

```
[no] ip dscp server <value>
```

Configure IP packet DSCP settings for flows to the server

```
[no] ip dscp server copy
```

Copy IP packet DSCP bits from the client to the server

| Parameter | Type    | Description   |
|-----------|---------|---|
| value     | Integer | Set IP packet DSCP value for flows to the client or server. |

---

## Ib-algorithm

Assign the load balancing algorithm.

### Use

Use to set the algorithm the load balancer uses to balance requests through the virtual server.

Available algorithms are:

- Round robin—Strict round robin load balancing algorithm, regardless of the connections in queue for each server.
- Round robin free—Round robin algorithm that only sends requests to those servers that are not already at maximum connections (ones with free connections).
- URL hash—Sends the same URL to the same web server each time, based on the system-generated hash. An example use case for this load balancing algorithm is to permit the web server to use cached data effectively. For most situations, the URL hash process works well. If you find that a specific URL is overloading the real servers because of a very high number of requests, use one of the following to set the rehash to a higher value:
  - CLI—Use the rehash option shown in the examples below.
  - REST API—Use the [urlHashRehash](#) node.
- Weighted least connections—Sends requests to the server that has the fewest number of connections, which helps to even out the connections across servers. The weighting creates a preference, in the form of a ratio, for the web servers with higher weights. Use the weights to rank web servers based on load capacity or speed. For example, if you assign a weight of 1 to one real server and 3 to another real server, the load balancer sends three times as many connections to the real server with the weight of 3. The default weight is 1.
  - Set the weight when attaching each real server to the virtual server:
    - CLI—[attach](#)
    - REST—[/config/app/proxy/virtualServer/<name>/realServer](#)
- Weighted round robin free—Weighted round robin algorithm that only sends requests to those servers that are not already at maximum connections (ones with free connections). The weighting creates a preference, in the form of a ratio, for the web servers with higher weights.

Use the weights to rank web servers based on load capacity or speed. For example, if you assign a weight of 1 to one real server and 3 to another real server, the load balancer sends three times as many connections to the real server with the weight of 3.

- Set the weight when attaching each real server to the virtual server:
  - CLI—[attach](#)
  - REST—[/config/app/proxy/virtualServer/<name>/realServer](#)

## Default Setting

round-robin-free

## Command Mode

config

## Syntax

`[no] lb-algorithm round-robin`

Set to round robin algorithm.

`[no] lb-algorithm url-hash`

Set to URL hash algorithm.

`[no] lb-algorithm round-robin-free`

Set to round robin free algorithm.

`[no] lb-algorithm weighted-round-robin-free`

Set to weighted round robin algorithm.

`[no] lb-algorithm weighted-least-conns`

Set to weighted least connections algorithm that sends requests to those servers with the fewest open connections.

`[no] lb-algorithm url-hash rehash <rehash>`

Set to URL hash rehash algorithm.

`no lb-algorithm`

Remove the configured algorithm.

| Parameter | Type | Description |
|-----------|------|-------------|
|-----------|------|-------------|

|        |      |   |
|--------|------|---|
| rehash | Real | The default for the URL hash algorithm is to automatically tune the rehash parameter and to attempt to use more than one real server if the primary real server becomes overloaded. A user-configured value of 0 turns rehashing off so that the system will never direct the same URL to more than one real server. When using URL hash, increase only if a specific web server is overloaded because of a very high number of requests. |
|--------|------|---|

---

## service http

Enable HTTP service.

### Use

Sets the current virtual server to be compatible with layer 7 load balancing, for web use. Use this for web servers that are using HTTP. The service setting on a virtual server must match the service setting on any real server attached to the virtual server. Use for HTTPS as well.

### Default Setting

Service default is http.

### Command Mode

config

### Syntax

```
service http
```

Enables HTTP service

---

## client-ip-header

Header name for all HTTP requests.

### Use

Use to label the name of the header where the system places the client's IP address.

### Default Setting

None

### Command Mode

config

### Syntax

`client-ip-header <header_name>`

Text for header that the proxy will add to all HTTP requests

`no client-ip-header`

Remove the configured client IP header

| Parameter   | Type   | Description  |
|-------------|--------|--|
| header_name | String | String to name the request header that contains the client IP address. |

---

## forward-connect-requests

Indicate if this virtual server should forward HTTP connect requests.

### Use

If you expect to see connect requests to your web servers, enable this to permit forwarding of connect requests. If you do not expect to see connect requests to your web servers, disable this to block the connect requests at the load balancer.

### Default Setting

Disabled

### Command Mode

config

### Syntax

`forward-connect-requests`

Permit this virtual server to forward HTTP connect requests

---

## hostname

Assigns a host name that this virtual server will respond to.

## Use

Use when you have the same virtual IP attached to more than one virtual server, and you use host names to direct requests to a specific virtual server. Assign the host name of the web server that you want the virtual server to respond to.

## Default Setting

None

## Command Mode

config

## Syntax

`hostname <name>`

A hostname that this virtual server will respond to

| Parameter | Type | Description   |
|-----------|------|---|
| name      | Word | Host name string (example: www.example.com).<br><br>Quotation marks should not be used. |

---

## persist

### Use

Use to enable session persistence, which lets the system send subsequent requests from a client to the same server to improve performance when the servers cache content or for applications that require requests from a client to be consistently sent to the same server.

You can configure session persistence the following ways:

- Using a cookie—Uses the cookie you specify for session persistence. Give the cookie a name that will be unique, to differentiate it from any cookies the servers may use. Use the `expires` option or the `/config/app/proxy/virtualServer/<name>/serviceHttp/persistSourceIp/idleTimeout` node to set when the cookie expires in seconds.
- Using the source IP—Uses the source IP address for session persistence. Use the `idle-timeout` option or the `/config/app/proxy/virtualServer/<name>/serviceHttp/persistSourceIp/idleTimeout` node to set when the session expires.
- Using the SSL session ID—Uses the SSL session ID for session persistence. This is most useful for SSL over TCP traffic (TCP virtual IP without an SSL profile attached to the



virtual IP). In this configuration, F5<sup>®</sup> LineRate<sup>®</sup> offloads the overhead of the SSL session establishment from the back-end server.

- Use the `idle-timeout` option or the `/config/app/proxy/virtualServer/<name>/serviceHttp/persistSslSessionId/idleTimeout` node to set how long the session ID stays live in the cache.
- You can use this configuration with HTTP over SSL and SSL over TCP traffic, but you do not offload any overhead from the back-end server.

If one method is already configured, and you want to change to the other method, you must remove the existing configuration, then configure the method you want.

### Default Setting

0 (Disabled)

### Command Mode

`config-vserver-http`

### Syntax

```
[no] persist cookie <name>
```

Enable session persistence by setting HTTP cookies

```
[no] persist cookie <name> expires <lifetime>
```

Set how long the cookie persists, in seconds, from the time of last client request. Use 0 to set no expiration, but the cookie still expires when the session ends.

```
no persist cookie
```

Remove the configured persist cookie

```
[no] persist source-ip
```

Enable session persistence using source IP

```
[no] persist source-ip idle-timeout <timeout>
```

Set the timeout value, in seconds, after which session persistence expires due to inactivity. The default is 300 seconds.

```
[no] persist ssl-session-id
```

Enable session persistence using SSL session ID

```
[no] persist ssl-session-id idle-timeout <idle_timeout>
```

Set the timeout value, in seconds, after which session persistence expires due to inactivity. The default is 300 seconds.

| Parameter    | Type    | Description   |
|--------------|---------|---|
| idle_timeout | Integer | Set the timeout value, in seconds, after which session persistence expires due to inactivity. The default is 300 seconds.   |
| lifetime     | Integer | Set how long the cookie persists, in seconds, from the time of last client request. Use 0 to set no expiration, but the cookie still expires when the session ends. |
| name         | Word    | Name of cookie to use for load balancing (for example, route).  |
| timeout      | Integer | Set the timeout value, in seconds, after which session persistence expires due to inactivity. The default is 300 seconds.   |

---

## request-rate-limit

### Use

Use to set the number of HTTP requests per second to send to the virtual server. Consider your traffic patterns and the capabilities of all of the servers this virtual server handles.

Use the burst size to set the maximum number of HTTP requests the servers can handle in a burst above the rate limit. This value may be no less than 2% of the rate limit. By default, the burst size is the same as the request rate limit you configure. For most situations, this works well. Change this setting only if your requests tend to come in bursts.

### Default Setting

0 (no limit)

### Command Mode

config-vserver-http

### Syntax

```
[no] request-rate-limit <limit>
```

Set the virtual server request rate limit

```
[no] request-rate-limit <limit> burst-size <burst>
```

Set the maximum burst size (default is the rate limit)

| Parameter | Type    | Description  |
|-----------|---------|--|
| burst     | Integer | Maximum number of requests handled in a burst above the rate limit. This value may be no less than 2% of the rate limit. |
| limit     | Integer | Maximum number of requests per second.   |

---

## strip-request-header

Delete all HTTP request headers with the specified name.

### Use

Use to remove specific request headers, perhaps when headers, like cookies, are very large. You can also use this to strip the byte-range request header, which forces the web server to respond with the entire content rather than only those bytes requested by the byte-range header. This is especially useful if the web servers are proxies that perform layer 7 inspection.

### Default Setting

None

### Command Mode

config

### Syntax

```
strip-request-header <header_name>
```

Delete all HTTP request headers with the specified name

| Parameter   | Type   | Description               |
|-------------|--------|---------------------------|
| header_name | String | Name of header to remove. |

---

## tcp-multiplex

Enables TCP multiplexing for this virtual server.

### Use

Enables multiplexing of HTTP requests processed by this virtual server to its associated web servers on one TCP connection. When enabled, the system permits multiple requests on a single TCP connection, resulting in better performance. When disabled, the system sends only one request, then closes the connection, and opens a new connection for the next request, resulting in more overhead.

For most situations, enabling TCP multiplexing improves performance. Make sure your web servers support handling multiple requests on a single TCP connection.

### **Default Setting**

Disabled

### **Command Mode**

config

### **Syntax**

```
tcp-multiplex
```

Enables TCP multiplexing for this virtual server

---

## **service tcp**

Enable TCP service.

### **Use**

Sets the current virtual IP to handle TCP connections. Use this service type for servers that are not using HTTP, for example, an email server.

### **Default Setting**

Service default is http.

### **Command Mode**

config

### **Syntax**

```
service tcp
```

Enables TCP service

---

## **persist**

## Use

Use to enable session persistence, which lets the system send subsequent requests from a client to the same server to improve performance when the servers cache content or for applications that require requests from a client to be consistently sent to the same server.

You can configure session persistence the following ways:

- Using the source IP—Uses the source IP address for session persistence. You can configure session persistence using the source IP. Use the `idle-timeout` option or the `/config/app/proxy/virtualServer/<name>/serviceTcp/persistSourceIp/idleTimeout` node to set when the session expires.
- Using the SSL session ID—Uses the SSL session ID for session persistence. This is most useful for SSL over TCP traffic (TCP virtual IP without an SSL profile attached to the virtual IP). In this configuration, LineRate offloads the overhead of the SSL session establishment from the back-end server.
  - Use the `idle-timeout` option or the `/config/app/proxy/virtualServer/<name>/serviceTcp/persistSslSessionId/idleTimeout` node to set how long the session ID stays live in the cache.
  - Use the `data-idle-timeout` option or the `/config/app/proxy/virtualServer/<name>/serviceTcp/persistDataIdleTimeout` node to set how long the system waits to receive enough data to determine if a persistence decision can be made. The system closes the connection after the time elapses to conserve resources.
  - You can use this configuration with HTTP over SSL and SSL over TCP traffic, but you do not offload any overhead from the back-end server.

## Default Setting

0 (Disabled)

## Command Mode

config-vserver-http

## Syntax

```
[no] persist data-idle-timeout <data_idle_timeout>
```

Set the timeout value, in seconds, to receive enough data for a persistence-based load-balancing decision. The default is 1 second.

```
[no] persist source-ip
```

Enable session persistence using source IP

```
[no] persist source-ip idle-timeout <timeout>
```

Set the timeout value, in seconds, after which session persistence expires due to inactivity. The default is 300 seconds.

`[no] persist ssl-session-id`

Enable session persistence using SSL session ID

`[no] persist ssl-session-id idle-timeout <idle_timeout>`

Set the timeout value, in seconds, after which session persistence expires due to inactivity. The default is 300 seconds.

| Parameter         | Type    | Description   |
|-------------------|---------|---|
| data_idle_timeout | Real    | Set the timeout value, in seconds, to receive enough data for a persistence-based load-balancing decision. The default is 1 second. |
| idle_timeout      | Integer | Set the timeout value, in seconds, after which session persistence expires due to inactivity. The default is 300 seconds.           |
| timeout           | Integer | Set the timeout value, in seconds, after which session persistence expires due to inactivity. The default is 300 seconds.           |



---

## Exec Commands

---

### Overview

If you are new to F5<sup>®</sup> LineRate<sup>®</sup>, we recommend working through the example configurations in the [Getting Started Guide](#) first.

This section is a reference for F5<sup>®</sup> LineRate<sup>®</sup> CLI exec commands.

---

### Contents

The guide is broken into the following sections:

- [Backup Mode Commands](#)
- [Bash Mode Commands](#)
- [Clear Mode Commands](#)
- [Configure Command](#)
- [Copy Mode Commands](#)
- [Debug Mode Commands](#)
- [Exit Command \(exec mode\)](#)
- [Halt Mode Commands](#)
- [IP Mode Commands](#)
- [License Mode Commands \(exec\)](#)
- [No Command \(exec mode\)](#)
- [NTP Mode Commands \(exec\)](#)
- [Phone Home Mode Commands](#)
- [Reload Mode Commands](#)
- [Restore Mode Commands](#)
- [Scripting Mode Commands](#)
- [Show Commands](#)
- [Terminal Mode Commands](#)
- [Upgrade Command](#)
- [Write Command](#)

---

## Backup Mode Commands

---

### backup

Back up the current configuration or system version.

#### Use

Use to create one of the following backup types:

- Quick—Backs up your current configuration (all files in /home/linerate, except the backups directory).
- Full—Backs up all files for the current version of F5<sup>®</sup> LineRate<sup>®</sup>, including all configuration and files. When you create a full backup, you can use it to do either a quick or full restore.



**Note:** Backups are specific to a version. You cannot use a version 2.3 backup to do a restore on a version 2.4 system.

---

You can save backups locally or to another server on your network.

We recommend naming backups with the system version, date, time, and backup type (quick or full). For local backups, the system automatically adds .tar.bz2 as the file extension. For backups to another server, you should add the file extension of either .tbz or .tar.bz2 to your file name.

To see existing local backups, use either of the following:

- CLI command—`show backup list`
- REST node—`/status/system/util/backup/list` or `/status/system/util/backup/list-detail`

You can encrypt backups using AES-256 encryption

- CLI command—Use the `encrypt` form of the command and provide a key. The same key is required for restoring the backup.
- REST node—Use the optional encryption key as described in the Data Key section.

You can encrypt backups using AES-256 with the `encrypt` form of the command and by providing a key. The same key is required for restoring the backup.

#### Default Setting



None

## Command Mode

exec

## Syntax

```
backup <uri> [encrypt <key>]
```

Does a quick backup of the current configuration, optionally encrypt the backup

```
backup <uri> delete
```

Deletes the specified backup

```
backup <uri> full [encrypt <key>]
```

Does a full backup of the current version of the system, optionally encrypt the backup

| Parameter | Type   | Description   |
|-----------|--------|---|
| key       | String | Encryption key to use when creating the backup and restoring the backup.  |
| uri       | String | URI to put the backup. If it does not end with '.tbz' or '.tar.bz2', the file extension is appended (for local files only). The system supports file:// and scp://. If a protocol prefix is not given, the system saves the file locally in /home/linerate/backups. Use quotes around URIs (for example, " <a href="file:///home/linerate/backups/orig-config.tar.bz2">file:///home/linerate/backups/orig-config.tar.bz2</a> " or just "orig-config").<br><br>We recommend naming backups with the F5 <sup>®</sup> LineRate <sup>®</sup> version, date, and time. |

## Examples

```
backup "ver1.5may11-2012-13:00"
```

Backs up all files in /home/linerate/ to the /home/linerate/backups directory and adds the .tar.bz2 file extension to the file.

```
backup "file:///home/linerate/backups/ver1.5...-13:00.tar.bz2"
```

This does exactly the same thing as the command above.

```
backup "scp://<server>/<directory>/ver1.5may11-2012-13:00.tar.bz2"
```

Uses secure copy to back up your configuration to the specified server and directory.

```
backup "scp://<server>/<directory>/ver1.5may11-2012-13:00.tar.bz2" full
```

Uses secure copy to back up all of version 1.5 to the specified server and directory.

### **Related Commands**

[Restore Mode Commands](#)

REST API Reference - [backup](#)

---

## Bash Mode Commands

1. [bash](#)
  1. [Using SCP](#)

---

### bash

Open a bash shell in interactive mode

#### Use

Use to access the bash shell to perform functions directly.



**Caution:** Take great care when using bash. Do not use bash to configure interfaces, network settings, /etc files, or any other configuration, because F5<sup>®</sup> LineRate<sup>®</sup> will not be aware of the configuration changes. **Do not make changes to the system configuration using bash unless technical support personnel instruct you to.**

---

Following are some common and safe uses of bash:

- Copy files from or to the system using `scp`.
- Use the `lros_shell --config <path_to_config_file_name>` command to reuse a configuration file from another system to configure this system. You must copy the configuration file to the system before using the command.
- Find the names of files on the system.
- Using the `tail` command with log files.

#### Default Setting

None

#### Command Mode

exec

#### Syntax

`bash`

Open a bash shell in interactive mode

```
bash "<args>"
```

Execute a single bash command and return to the LROS shell prompt.

| Parameter | Type   | Description                   |
|-----------|--------|-------------------------------|
| args      | String | Bash shell command to execute |

### Interactive Mode Example

```
example_host# bash
```

```
*****WARNING*****
```

The bash prompt allows unrestricted access to the system. It is possible to configure the system in ways that cannot be shown in the UI, that may lead to incorrect operation of the system, and that may or may not be persistent after a reload of the system. F5® recommends that no configuration be made from bash unless directed by support.

```
*****
```

```
[admin@example_host ~]$ lros_shell --config <config_file_name>
```

### Single Command Mode Example

```
example_host# bash "sudo tail -f /var/log/controller.messages"
```

---

## Using SCP

When you upgrade your system, you must download the upgrade file, then install it. One way to do the installation is copy the upgrade file to the F5® LineRate® system using scp before performing the upgrade.



**Caution:** Make sure you do not overwrite existing system files using scp.

---

### Syntax

```
scp <local_image.upg.gz> admin@<LineRate Proxy_ip>:/home/linerate/.
```

Use this command from the system on your network where you downloaded the upgrade file to copy the upgrade file to the F5® LineRate® system.

```
LROS# bash
```

```
scp <remote_username>@<remote_system_ip>:<path_to_image> .
```

```
exit
```

Use these commands from the F5<sup>®</sup> LineRate<sup>®</sup> system to copy the upgrade file from the system on your network where you downloaded it to the F5<sup>®</sup> LineRate<sup>®</sup> system. This copies the file to the /home/linerate directory.

---

## Clear Mode Commands

---

### clear

#### Use

Use to remove routes from the routing table and reinstall the static routes you have configured in F5<sup>®</sup> LineRate<sup>®</sup>. The clear process removes any routes configured using bash or another process outside of the F5<sup>®</sup> LineRate<sup>®</sup> console.

#### Default Setting

None

#### Command Mode

exec

#### Syntax

```
clear ip route *
```

Clears the IPv4 routing table and reinstalls configured static routes

```
clear ipv6 route *
```

Clears the IPv6 routing table and reinstalls configured static routes

#### Related Commands

[ip route](#)

[ipv6 route](#)

REST API Reference - [clear](#)



---

## Configure Command

### Use

Use to go into configuration mode to change settings for F5<sup>®</sup> LineRate<sup>®</sup> software. Configure has many submodes that you may enter when using a command in config mode. The prompt changes to reflect the config submode.

For example, when you type:

```
configure
```

the prompt changes to:

```
LROS (config) #
```

When you type:

```
real-server rs1
```

the prompt changes to:

```
LROS (config-rserver:rs1) #
```

### Default Setting

None

### Command Mode

```
exec
```

### Syntax

```
configure
```

Enter configuration mode.

```
configure terminal
```

This form of the command does the same thing and is available for compatibility if you are accustomed to other network operating systems.

## **Related Commands**

[Using Command Line Modes](#)



---

## Copy Mode Commands

---

### copy

Copy a file.

#### Use

Use to copy a file specifying the source and destination file names. You may want to use this to copy the current running configuration or startup configuration file. See [Running Config and Startup Config](#).



**Caution:** Take care when copying to the startup-config file, because the source file overwrites the contents of the start-up config file. The system uses the start-up config file when it loads, and improper configuration could cause instability or cause the system not to load.

---

You can also use this command to copy a snippet of configuration that you have in a file to the running config. The copy command applies the commands, as if you typed them in, and adds them to the running config. Copying to the running config does not overwrite the contents of the running config.

#### Default Setting

None

#### Command Mode

exec

#### Syntax

```
copy <src> <dst>
```

Copy the source to the destination file

```
copy <src> running-config
```

Add the source file configuration to the current operating (unsaved) configuration; this does not overwrite the running config file

`copy <src> startup-config`

---



Overwrite the startup config file with the contents of the source file.

---

`copy running-config <dst>`

Copy the current (unsaved) running config to the destination file

`copy running-config startup-config`

Copy the current (unsaved) configuration to the startup-config file (same as using **write**)

`copy startup-config <dst>`

Copy the current (saved) startup config to the destination file

`copy startup-config running-config`

Add the current (saved) startup config to the running config file; this does not overwrite the running config file. This lets you return to the saved configuration.

| Parameter | Type   | Description           |
|-----------|--------|-----------------------|
| dst       | String | Destination file name |
| src       | String | Source file name      |

## Related Commands

[Write Command](#)

REST API Reference - [copy](#)

---

## Debug Mode Commands

1. [debug](#)
  1. [js-heap-profile](#)
  2. [js-run-gc](#)

---

### debug

Enables debugging output

#### Use

Use only when directed by technical support personnel.



**Caution:** Enabling debug functions may have a significant impact on system performance. Use only with extreme caution on a production system. Debug recordings take disk space, so leaving a debug function enabled may use all available disk space.

---

#### Default Setting

None

#### Command Mode

exec

#### Syntax

`[no] debug controller cpu-profile`

Enable CPU profiling for the system management controller. Create CPU profile recordings in `/home/data/linerate/profile`. Only F5 can properly interpret these recordings. This command should only be used when directed by F5 support.

`[no] debug proxy cpu-profile`

Enable CPU profiling for the proxy. Create CPU profile recordings in `/home/data/linerate/profile`. Only F5 can properly interpret these recordings. This command should only be used when directed by F5 support.

**[no] debug proxy heap-profile**

Enable heap profiling for the proxy. Create recordings of heap memory allocations in /home/linerate/data/profile. Only F5 can properly interpret these recordings. This command should only be used when directed by F5 support.

**[no] debug proxy trace**

Enable verbose tracing of connection processing in the system logs (/var/logs). Only F5 can properly interpret these messages. This command should only be used when directed by F5 support.

**[no] debug uiprotoocol messages**

Use only when directed by technical support personnel to enable capturing the messages that all system management interfaces, such as, REST, CLI, and SNMP, use.

## Related Commands

REST API Reference - [debug](#)

---

## js-heap-profile

### Use

Scripts may have bugs that cause objects to be retained longer than needed. These retained objects use memory on the system, which can affect performance. You can inspect the heap objects that are retained by a script to determine if all of the retained objects should be retained, or if a bug has caused some objects to be retained too long.

One tool to inspect the Javascript heap is the Google Chrome heap profiler, which is available in any Google Chrome browser.

For more information about the Chrome Heap Profiler, refer to:

<https://developers.google.com/chrome-developer-tools/docs/heap-profiling>

A system with Google Chrome Developer Tools is required, this is the profiler system. The profiler system can run any operating system for which Chrome is available.

### Default Setting

None

### Command Mode

exec

### Syntax

**[no] debug proxy js-heap-profile**

Enables JavaScript heap profiling for the proxy

---

## js-run-gc

### Use

Use to run garbage collection on the scripting engine. The scripting engine runs Javascript, which is a garbage-collected language. Scripting has a high-performance generational garbage collector, so running this command is unnecessary. You should not run this command while processing traffic, because it will halt traffic processing while it runs. It can take longer than one second to run.

### Default Setting

None

### Command Mode

exec

### Syntax

```
[no] debug proxy js-run-gc
```

Run garbage collection on the scripting engine. Note: running the garbage collector will impact performance.

---

## Exit Command (exec mode)

### Use

Use to exit the LROS shell. When in exec mode (LROS# prompt) directly on the F5<sup>®</sup> LineRate<sup>®</sup> system, this returns you to the login prompt for the system. When in exec mode from SSH, this returns you to the SSH prompt.

### Default Setting

None

### Command Mode

exec

### Syntax

`exit`

---

## Halt Mode Commands

1. [halt](#)

---

### halt

Shutdown and power off the system

#### Use

Use to shut down the system, including the hardware.

If a backup, restore, or upgrade is in progress, we recommend waiting until these processes finish. They may take a few minutes. Using the force option risks disk corruption.

#### Default Setting

None

#### Command Mode

exec

#### Syntax

**halt**

Shut down and power off the system, with a confirmation prompt

**halt force**

Force a shutdown even if backup, restore, or upgrade is in progress, with a confirmation prompt. Risk of disk corruption.

**halt no-prompt**

Shut down and power off the system, but no confirmation prompt

**halt force no-prompt**

Force a shutdown even if backup, restore, or upgrade is in progress, but no confirmation prompt. Risk of disk corruption. Also valid: **halt no-prompt force**.

## Related Commands

REST API Reference - [halt](#)



---

## IP Mode Commands (exec)

1. [ip dhcp renew](#)

---

### ip dhcp renew

Renew the DHCP lease.

#### Use

Use to renew the DHCP lease on an interface. Typically DHCP leases renew automatically, but sometimes you need to renew a lease sooner. For example if network changes cause the old DHCP lease to be invalid (for example, you connect the interface to a different network), you would need to renew the lease.

#### Default Setting

None

#### Command Mode

exec

#### Syntax

```
ip dhcp renew <int>
```

Synchronize with a specified NTP server

| Parameter | Type   | Description   |
|-----------|--------|---|
| int       | String | Name of the interface whose DHCP lease you want to renew. |

---

## License Mode Commands (exec)

1. [license](#)

---

### license

#### Use

Use to install a license file and to refresh the license status.

To purchase a subscription license, go to [linerate.f5.com/try](https://linerate.f5.com/try). For other licensing options, [contact sales](#).

After you install F5<sup>®</sup> LineRate<sup>®</sup>, you can install the license.

The following are required for your purchased license to automatically renew:

- The credit card on file must be active and must process the purchase or renewal.
- The F5<sup>®</sup> LineRate<sup>®</sup> hardware must have Internet connectivity.
- A F5<sup>®</sup> LineRate<sup>®</sup> interface must be configured with either DHCP or a default route and IP address.
- F5<sup>®</sup> LineRate<sup>®</sup> must have licensing set to auto.



**Note:** If your F5<sup>®</sup> LineRate<sup>®</sup> system does not meet one or more of the criteria, you can manually install and renew the license before the license period expires. See [Manually Installing a Purchased License](#).

---

The rate limits for HTTP requests, TCP connections, and Mb per second are based on the license you purchased. For more information about how licenses work, see [About Licensing](#).

Currently, the only feature you can license is called base.

For the complete licensing process, see [Configuring Licensing](#).

#### Default Setting

None

#### Command Mode

exec

## Syntax

```
license install base <uri>
```

Install license from a file.

```
license install force base <uri>
```

Force a license install even if an active license for this feature currently exists.

```
license refresh base
```

Immediately retrieve license status for a feature. Currently, the only feature available is called base.

| Parameter | Type   | Description   |
|-----------|--------|---|
| uri       | String | URI of the license file to install. System supports file:// protocol. If the protocol prefix is not given, start the URI with a / for an absolute path and start without a / for a relative path from /home/linerate. A maximum file size of 100 kB is enforced. Protect URIs with quotes (for example, "file:///home/linerate/license" or just "license"). |

## Related

CLI Reference Guide - [Licensing Mode Commands \(config\)](#)

Getting Started Guide - [Configuring Licensing](#)

REST API Reference - [license](#)

---

## About Licensing

1. [Overview](#)
2. [Starter Edition Renewals](#)
3. [Purchased License Renewals](#)
4. [Rate Limits](#)
5. [Bandwidth Calculation](#)

---

## Overview

Both the Starter Edition and purchased F5<sup>®</sup> LineRate<sup>®</sup> licenses define the length of the license and rate limits.

For the complete licensing process, see [Configuring Licensing](#).

---

## Starter Edition Renewals

Starting two days before expiration, the system attempts to phone home every minute to get a new license. A banner about the expiring license also displays when you log in. As long as the F5 username and password are configured, phone home will renew your license for another two weeks.

For more information about phone home, see [Phone Home Mode Commands](#).

---

## Purchased License Renewals

Starting two days before the license expiration date, a banner displays when you log in that says the feature license is expiring.

If your credit card is still active and you have licensing activation set to auto, F5<sup>®</sup> will charge your monthly fee on the expiration date, and the license will renew for one month. If licensing activation is not set to auto, you must pay for your renewal before the expiration and activate the license. See [Upgrading or Renewing a License](#).



**Note:**

---

---

If your license expires, which happens only if the renewal payment is not made, the system starts using a Starter Edition license after expiration. However, the system can only activate the Starter Edition license if valid phone home credentials are configured and phone home is working.

---

## Rate Limits

Licenses define the expiration date of the license and the rate limits for:

- HTTP requests per second—When limit is reached, clients receive an HTTP 503 error.
- TCP connections per second—When limit is reached, clients receive a connection reset.
- Mb per second (bandwidth)—When limit is reached, the system slows traffic. See below for information about how the system counts bandwidth.
- Burst duration—Acts as a multiplier for each licensed rate limit. The `<burst_duration>` x each rate limit sets the maximum number of HTTP requests, TCP connections, and Mb per second the system can handle in a burst above the rate limit. For example, if the rate limit is 100 HTTP requests per second and the burst duration is 5, the system can handle bursts up to 500 HTTP requests per second (5x the limit).`<burst_duration>`

For licenses with a larger burst size, as in the Starter Edition license, the `show licensing` commands report the rate limits in minutes.

Starting two days before the expiration date, a banner displays when you log in that feature license is expiring.

---

## Bandwidth Calculation

The system uses rate shaping (also called traffic shaping) to limit the bandwidth. On HTTP services, all layer 7 payload traffic is counted, but nothing at other layers. This will cause the throughput to appear to be more at the interface level than the licensed rate. For TCP services, the traffic counted is the layer 4 payload.

The bandwidth is limited at all points where data can enter or exit the data path. The points controlled are:

- HTTP virtual IP (request/response)
- HTTP real server (request/response)
- HTTP forward proxy (request/response)
- TCP virtual IP (read/write)
- TCP real server (read/write)
- TCP forward proxy (read/write)
- F5<sup>®</sup> LineRate Scripting `client.http.request`
- F5<sup>®</sup> LineRate Scripting `script client.http.response`

- F5<sup>®</sup> LineRate Scripting script TCP socket (read/write)

In the example below, a 100-byte HTTP request generates a 250-byte response from the web server and consumes 760 bytes of bandwidth:

- 100 bytes from the client to the virtual server
- 20 bytes from the virtual server to the external database via a script
- 40 bytes from the external database to the virtual server via a script
- 100 bytes from the real server to the web server
- 250 bytes from web server to real server
- 250 bytes from the virtual IP to the client

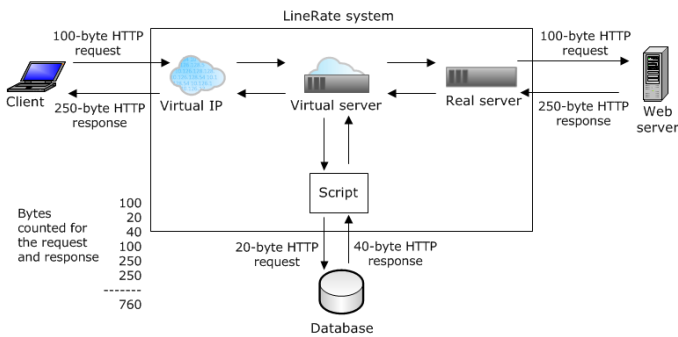

Bandwidth counting example - HTTP request

In the example below, a 100-byte TCP connection generates a 100-byte connection to the web server and consumes 400 bytes of bandwidth:

- 100 bytes from the client to the virtual server
- 100 bytes from the real server to the web server
- 100 bytes from web server to real server
- 100 bytes from the virtual IP to the client

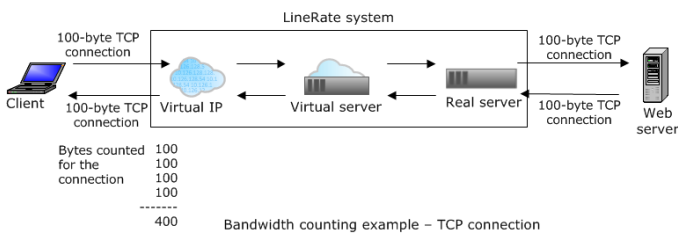

Bandwidth counting example - TCP connection

---

## No Command (exec mode)

Negates or removes the specified command or item.

### Use

Use to turn off debug commands.

### Default Setting

None

### Command Mode

exec

### Syntax

`no debug`

### Related Command

[No Command \(config mode\)](#)

---

## NTP Mode Commands (exec)

1. [ntp](#)

---

### ntp

Execute NTP time synchronization.

#### Use

Use to synchronize the system's clock with an NTP server immediately. The NTP server is specified by an IP address. Unlike configuring NTP using the `config ntp server` command, this immediate synchronization jumps the system's clock forward or backward to be synchronized, and will not correct for future drift.

#### Default Setting

None

#### Command Mode

exec

#### Syntax

```
ntp sync <server>
```

Synchronize with a specified NTP server

| Parameter | Type   | Description                  |
|-----------|--------|------------------------------|
| server    | IPAddr | IP address of the NTP server |





---

## Phone Home Mode Commands (exec)

1. [phone-home ihealth upload](#)

---

### phone-home ihealth upload

Send bundle file to the F5<sup>®</sup> LineRate<sup>®</sup> iHealthsystem.

#### Use

Use to upload a bundle file to the F5<sup>®</sup> LineRate<sup>®</sup> iHealth system to help with diagnosing any system issues. Currently, the iHealth system is available to F5<sup>®</sup> personnel for diagnostic purposes. The bundle file contains the following:

- A compressed file with JSON content of the entire system configuration. Sensitive information is redacted.
- System logs (all files in /var/log).
- Script events (create, remove, online, offline, run-time errors, inline script code).
- Core files, starting with the most recent up to the maximum size of 4 GB.
- The username.txt file, which contains the configured phone home username.

To use this feature, you must configure a phone home username and password. For Amazon EC2, you must also accept the phone home terms.

The upload may take a few minutes and must complete before you see a success message.

#### Default Setting

None

#### Command Mode

exec

#### Syntax

```
phone-home ihealth upload
```

Sends a bundle file to the F5<sup>®</sup> LineRate<sup>®</sup> iHealth system

#### Related

CLI Reference - [Phone Home Mode Commands](#)

CLI Reference - [Show Phone Home Commands](#)

REST API Reference - [/exec/phoneHome/iHealth/upload](#)

---

## Reload Mode Commands

---

### Reload

Shut down and restart the system.

#### Use

Use to reload the current version or a different version of the system. If you have used the `boot` command or `/config/system/boot/version` node to set up a different version to reload, use the `reload` command or `/exec/system/reload` node when you are ready to actually reload that version.



**Caution:** The `reload` command or `/exec/system/reload` node ends all connections and shuts down the system, then restarts the system.

---

If an upgrade, restore, or backup is in process, the system lets you know and does not continue with the reload.

---



**Caution:** Use the force option only in extreme situations. Forcing a reload during an upgrade, restore, or backup may corrupt the system, and the system may not function at all.

---

#### Default Setting

None

#### Command Mode

exec

#### Syntax

`reload`

Shut down system and restart

`reload force`

Force a reload even if backup, restore, or upgrade is in progress. Risk of disk corruption.

### **Related Commands**

[Boot Mode Commands](#)

REST API Reference - [reload](#)

---

## Restore Mode Commands

---

### restore

Restore configuration or full system version from backup.

#### Use

After using the backup command to create a backup, you can restore from the backup in one of the following ways:

- Quick—Restores your current configuration (all files in /home/linerate, except the backups directory). You can use either a quick or full backup to do this type of restore.
- Full—Restores all files for the current version of F5<sup>®</sup> LineRate<sup>®</sup>. You can only use a full backup for this type of restore. Use this type of restore if you find some system files are missing or have become corrupted.



**Note:** Backups are specific to a version. You cannot use a version 1.5 backup to do a restore on a version 1.4 system.

---

To see existing local backups, use either of the following:

- CLI command—`show backup list`
  - REST node—`/status/system/util/backup/list` or `/status/system/util/backup/list-detail`
- 



**Caution:** After you do a restore, the system immediately does a reload. The reload shuts down the system, then restarts it.

---

If the backup was encrypted, you must decrypt the restore:

- CLI command—Use the `decrypt` form of the command and provide the same key as used for the backup.
- REST node—Use the same key as used in the backup as described in the Data Key section.

#### Default Setting

None

## Command Mode

exec

## Syntax

```
restore <uri> [decrypt <key>]
```

Does a quick restore from the specified backup

```
restore <uri> full [decrypt <key>]
```

Does a full restore from the specified backup

| Parameter | Type   | Description   |
|-----------|--------|---|
| key       | String | String that was used when creating the backup.  |
| uri       | String | URI of the backup to restore from. The system supports file:// and scp://. If a protocol prefix is not given, the system looks for a local file in /home/linerate/backups. Use quotes around URIs (for example, "file:///home/linerate/backups/orig-config.tar.bz2" or just "orig-config"). |

## Examples

```
restore "ver1.5may11-2012-13:00"
```

Restores the configuration from a file in /home/linerate/backups.

```
restore "file:///home/linerate/backups/ver1.5may11-2012-13:00.tar.bz2"
```

This does exactly the same thing as the command above.

```
restore "scp://<server>/<directory>/ver1.5may11-2012-13:00.tar.bz2"
```

Uses secure copy to restore your configuration from the specified server, directory and file.

```
restore "scp://<server>/<directory>/ver1.5may11-2012-13:00.tar.bz2" full
```

Uses secure copy to restore all of version 1.5 to the specified server, directory, and file.

## Related Commands

[Backup Mode Commands](#)

[Reload Mode Commands](#)

REST API Reference - [restore](#)

---

## Scripting Mode Commands

---

### scripting

Execute commands related to the scripting system.

#### Use

Use to install and uninstall Node Packaged Modules.

Modules installed using `npm` are available globally (to all scripts) using `require('<module-name>')`, and are stored on the system in directory: `/home/linerate/data/scripting/lib/node_modules`.



**Note:** If you enable a Point™ Load Balancer license, you can install Node Packaged Modules, but any configured scripts will not run. If you later upgrade to a Precision™ Load Balancer license, all configured scripts with valid source and admin status set to online will start.

---

#### *Install*

Use to install a Node Packaged Module. The `npm` command is a package manager similar to the one provided for the Node.js platform.

The `scripting install npm` command installs a Node Packaged Module from the same default registry as the `npm` for Node platform, if no registry is specified.

The `install` command downloads and installs the specified module. The installation may take from a few seconds to a few minutes. Nothing displays during the installation. After a successful installation, the name and version of the module, and where it was installed displays, along with any warnings and any dependencies. All dependencies are also installed.

The name of the Node Packaged Module (`<module_name>` in the CLI and "name" key in REST) is a string and can be one of the following:

- `<tarball-file>`—Install from a tarball file already available on your system.

```
scripting npm install "/tmp/sampleModule.tgz"
```

- `<tarball-url>`—Install from a remote tarball.



```
scripting npm install "https://devcentral.f5.com/linerate/modules/tarball/sampleModule.tar.gz"
```

- <name>—Install the latest version of package published on npm.

```
scripting npm install async
```

- <name@version>—Install the specified version of a package published on npm.

```
scripting npm install "async@0.2.9"
```

If you see errors after you attempt to install, you can find more information about the errors in the following default system logs:

- /var/logs/controller.messages—This file will have some additional information.
- /home/linerate/data/scripting/npm-debug.log—This file will have even more information and is overwritten with each npm error.

### *Registry*

Use the registry option to specify the registry that you want to install from. If not specified, the system uses the official public npm registry: <http://registry.npmjs.org>. Before specifying another registry in the install command, you must configure the registry. See [npm Mode Commands](#).

### *Uninstall*

Use to uninstall a Node Packaged Module that you no longer need.

Uninstalling a module leaves behind files in cache. You can use **cache clean** to remove those file.

### *Cache Clean*

Uninstalling a Node Packaged Module leaves behind files in cache. To be sure that reinstalling the module uses the latest version, use **cache clean** to remove the cache files.

## **Default Setting**

None

## **Command Mode**

exec

## **Syntax**

```
scripting npm cache clean
```

Clear npm cache, after uninstalling a module.

```
scripting npm install <module_name>
```

Install specified module.

```
scripting npm install <module_name> registry <reg_name>
```

Specify an npm registry to use for the installation.

```
scripting npm install <module_name> registry <reg_name> timeout <sec>
```

Specify an npm registry and timeout period to use for the installation.

```
scripting npm uninstall <module_name>
```

Uninstall the specified module.

| Parameter   | Type    | Description   |
|-------------|---------|---|
| module_name | String  | Name or URL of the node packaged module. Protect name or URLs with quotes ("underscore@1.4.4" or "https://github.com/documentcloud/underscore/archive/1.4.4.tar.gz"). |
| reg_name    | Word    | Name of the npm registry.   |
| sec         | Integer | Number of seconds the system should wait for a response from the registry. The default is 90 seconds.   |

### Related Commands

REST API Reference - [scripting](#)

CLI Reference - [npm Mode Commands](#)

---

## Show Commands

This page was not added to the PDF due to the following tag(s): article:topic-guide

---

## Show Backup Commands

1. [show backup](#)

---

### show backup

#### Use

Use to list the the available backup files.

#### Default Setting

None

#### Command Mode

exec

#### Syntax

```
show backup list
```

Shows a list of available backups

```
show backup list detailed
```

Shows detail about available backups, including the backup type. This command may take a few minutes.

#### Example

```
show backup list
```

Available backups:

```
Backup Name
```

```
-----
```

```
mybackup1.tar.bz2
```

```
ver1.5may11-2012-13:00.tar.bz2
```

```
ver1.5.0-5-22-12.tar.bz2
```

```
ver1.5.0-5-22-12--1.tar.bz2
```

```
ver1.5.6-8-27-12.tar.bz2
```

## **show backup list detailed**

Available backups:

| Backup Name | Type | Version |
|-------------|------|---------|
|-------------|------|---------|

|                                |         |       |
|--------------------------------|---------|-------|
| mybackup1.tar.bz2              | partial | N/A   |
| ver1.5may11-2012-13:00.tar.bz2 | partial | N/A   |
| ver1.5.0-5-22-12.tar.bz2       | partial | N/A   |
| ver1.5.0-5-22-12--1.tar.bz2    | partial | N/A   |
| ver1.5.6-8-27-12.tar.bz2       | full    | 1.5.6 |

## **Related**

[Backup Mode Commands](#)

[Restore Mode Commands](#)

REST API Reference - [backup](#)

---

## Show Boot Commands

1. [show boot](#)

---

### show boot

#### Use

Use to view the F5<sup>®</sup> LineRate<sup>®</sup> version that will load when you use the **reload** command. You can change the version that will load using one of the following:

- CLI command—**boot system <version>**
- REST node—`/config/system/boot/version`

#### Default Setting

None

#### Command Mode

exec

#### Syntax

```
show boot system
```

Shows the version that will load with the next reload.

#### Related

[Boot Mode Commands](#)

[Reload Mode Commands](#)

REST API Reference - [boot](#)

---

## Show CARP Commands

---

### show carp

#### Use

Use to show information about your CARP settings.

#### Default Setting

None

#### Command Mode

exec

#### Syntax

```
show carp
```

Show CARP settings for all CARP groups and interfaces on the system

```
show carp <vhid>
```

Show CARP settings only for the specified CARP group

```
show carp interface <intf>
```

Show CARP settings only for the specified CARP interface

| Parameter | Type    | Description   |
|-----------|---------|---|
| intf      | String  | Name of an interface.                                   |
| vhid      | Integer | Virtual Host ID (VHID) used to identify the CARP group. |

#### Examples

```
show carp
bce0 - Group 43
State is Backup since Tue Jul 10 09:42:16 2012
```

```
Administrative state is up
Virtual IP address is 202.0.115.2/32
Virtual MAC is 0000.5e00.012b
Priority 24
Master is 202.0.119.1 (remote), priority is 20
em1 - Group 42
State is Init since Tue Jul 10 09:42:16 2012
Administrative state is down
Virtual IP address is 201.0.115.2/32
Virtual MAC is 0000.5e00.012a
Priority 24
Master is Unknown, priority is Unknown
em1.2001 - Group 77
State is Init since Tue Jul 10 09:42:16 2012
Administrative state is down
Virtual IP address is 101.0.115.2/32
Virtual MAC is 0000.5e00.014d
Priority 24
Master is Unknown, priority is Unknown
bce0.2002 - Group 78
State is Backup since Tue Jul 10 09:42:16 2012
Administrative state is up
Virtual IP address is 102.0.115.2/32
Virtual MAC is 0000.5e00.014e
Priority 24
Master is 102.0.119.1 (remote), priority is 20
```

#### **show carp 77**

```
em1.2001 - Group 77
State is Init since Tue Jul 10 09:42:16 2012
Administrative state is down
Virtual IP address is 101.0.115.2/32
Virtual MAC is 0000.5e00.014d
Priority 24
Master is Unknown, priority is Unknown
```

#### **show carp interface em1.2001**

```
em1.2001 - Group 77
State is Init since Tue Jul 10 09:42:16 2012
Administrative state is down
Virtual IP address is 101.0.115.2/32
Virtual MAC is 0000.5e00.014d
Priority 24
Master is Unknown, priority is Unknown
```

## **Related**

[interface CARP](#)



REST API Reference - [carp](#)

---

## Show Certificate Commands

Use the following commands to display information about certificates.

---

### show certificate

#### Use

Use to display information about existing certificates and certificate bundles.

The detailed form of the commands for a specific certificate or bundle are useful to see the valid dates, the common name (CN), and the key size.

#### Default Setting

None

#### Command Mode

exec

#### Syntax

`show certificate brief`

Display summary information for all installed certificates and certificate bundles

`show certificate bundle brief`

Display summary information for all installed certificate bundles

`show certificate <cert_name>`

Display the detailed information about the specified single certificate

`show certificate bundle <bundle_name>`

Display the detailed information about the specified certificate bundle

| Parameter   | Type | Description                    |
|-------------|------|--------------------------------|
| bundle_name | Word | Name of the certificate bundle |

| cert_name | Word | Name of the certificate |
|-----------|------|-------------------------|
|-----------|------|-------------------------|

## Examples

### show cert brief

Certificate Subject Common Name (CN)

```
-----
cert_chain_secure.example.com1 Example Corp Intermediate CA
cert_prim_secure.example.com secure.example.com
self-signed lros-default-host
Certificate Bundle Subject Common Name (CN)
```

```
-----
cert_bndlsecure.example.com VeriSign Class 3 Public Primary Certification Authority - G5
VeriSign Class 3 International Server CA - G3
VeriSign Class 3 Secure Server CA - G3
```

### show certificate bundle brief

Certificate Bundle Subject Common Name (CN)

```
-----
---
cert_bndlsecure.example.com VeriSign Class 3 Public Primary Certification Authority - G5
VeriSign Class 3 International Server CA - G3
VeriSign Class 3 Secure Server CA - G3
```

### show certificate cert\_chain\_secure.example.com1

Certificate:

Data:

Version: 1 (0x0)

Serial Number: 1 (0x1)

Signature Algorithm: sha1WithRSAEncryption

Issuer: C=US, ST=Colorado, L=Louisville, O=Example Corp., CN=Example Corp. CA

Validity

Not Before: Feb 11 02:12:30 2012 GMT

Not After : Feb 8 02:12:30 2022 GMT

Subject: C=US, ST=Colorado, L=Louisville, O=Example Corp., CN=Example Corp Intermediate CA

Subject Public Key Info:

Public Key Algorithm: rsaEncryption

Public-Key: (2048 bit)

Modulus:

```
00:d9:70:81:18:70:b5:29:8e:ef:01:87:3f:d9:e3:
68:fe:8e:6d:39:09:fc:0f:64:99:28:59:74:3c:56:
bf:ad:24:f2:8b:74:0a:99:fb:3c:8f:aa:bf:95:37:
a0:94:b8:46:fb:6f:eb:77:aa:67:ba:4d:ce:17:b6:
4a:ee:e6:42:19:db:ed:32:c8:75:cf:15:0b:2d:9b:
a5:41:0e:aa:0d:bd:c0:aa:0a:d5:b9:07:27:a9:31:
88:c4:45:92:f7:c5:21:f3:5b:87:59:04:51:7b:1c:
0e:8a:35:b6:c9:3b:6e:01:40:f5:08:82:ad:6a:ce:
81:57:0a:d3:96:2f:72:25:67:29:67:ef:dc:8b:84:
4d:9b:b2:ad:5b:3c:c5:eb:66:3c:7c:5e:42:65:e2:
0d:21:ed:f2:2e:af:b4:a6:2f:8e:c1:f3:83:d3:2d:
92:76:3c:d0:aa:92:fa:bb:d8:9b:87:85:ef:d8:09:
85:2a:ad:82:d2:27:47:04:59:65:3c:7a:53:92:8f:
```

```
89:c4:7c:4c:f3:02:0c:85:e6:5c:78:15:9b:33:f5:
b9:f8:20:e2:25:ac:bb:ac:ca:bc:b9:14:85:62:e1:
d6:07:8b:b4:95:bf:77:f6:b4:36:6a:52:46:4e:0a:
31:90:63:c5:26:b4:43:32:7d:49:5f:3a:1c:58:9b:
eb:79
```

```
Exponent: 65537 (0x10001)
```

```
Signature Algorithm: sha1WithRSAEncryption
```

```
a3:b8:7c:7d:e3:87:03:29:35:10:36:38:86:a6:f3:53:a7:58:
b8:bf:07:fb:33:fb:35:bf:eb:88:d7:78:0c:b1:02:df:71:71:
ac:14:43:10:2d:54:08:a3:24:56:db:79:09:47:a9:2c:2d:ee:
de:c8:50:21:e5:48:d0:e0:6e:7e:f8:e1:80:79:97:59:f8:06:
6b:fd:98:ee:c0:ef:57:12:2f:b8:2d:52:31:97:b3:ec:e9:c2:
6e:8a:fe:fa:9e:d9:98:a2:a3:a9:05:a8:25:52:ac:6f:bb:c1:
04:80:1e:3a:a8:7d:3c:1e:e2:2c:c0:f0:95:4f:6e:2a:0b:e7:
fb:e2:a7:e9:f5:a2:18:e3:f7:43:f6:1f:7c:63:2b:64:51:bd:
81:dd:a1:b5:11:f3:16:05:da:ab:5a:67:bf:25:07:e1:f6:c7:
08:3d:42:69:4b:b6:8c:99:60:c7:eb:ce:46:63:0d:49:4c:9c:
25:42:01:6c:c4:c0:d3:18:ad:11:dc:70:81:48:17:07:1f:02:
a9:6c:27:80:44:9d:61:94:66:d0:55:3e:d5:a4:3d:3d:c5:b7:
25:de:c2:00:ec:b4:25:89:31:c2:f6:8f:ae:91:ba:76:ce:90:
41:bc:34:e1:7e:92:26:33:7d:50:5a:2c:09:1a:3b:b6:4a:c8:
27:ec:26:73
```

```
show certificate bundle <bundle_name>
```

Displays either Configured inline or Configured via file: file\_name, followed by each certificate in the bundle the same way the **show certificate** <cert\_name> command (above) does.

## Related Commands

[Certificate Mode Commands](#)

REST API Reference - [certificateBundles](#)

REST API Reference - [certificates](#)

---

## Show Debug Commands

1. [debug](#)

---

### debug

#### Use

Use only when directed by technical support personnel to enable debugging features.



**Caution:** Enabling debug functions may have a significant impact on system performance. Use only with extreme caution on a production system. Debug recordings take disk space, so leaving a debug function enabled may use all available disk space.

---

#### Default Setting

None

#### Command Mode

exec

#### Syntax

```
show debug load-balancer object-count
```

Shows counts of objects present in the system

```
show debug sysdb internals [show-internal]
```

Displays all sysdb nodes, optionally including those marked as internal

```
show debug sysdb path-only [show-internal]
```

Displays all sysdb node paths, optionally including those marked as internal

```
show debug sysdb value <name>
```

Shows the sysdb value

`show debug sysdb value <name> detailed`

Shows more detail about the sysdb value

| Parameter | Type | Description          |
|-----------|------|----------------------|
| name      | Word | Sysdb value to show. |

### Related

REST API Reference - [debug](#)

---

## Show Failover Commands

1. [show failover](#)

---

### show failover

#### Use

Use to show failover group information.

#### Default Setting

None

#### Command Mode

exec

#### Syntax

```
show failover group <group_name>
```

Show information about failover group

```
show failover group brief
```

Show summary of failover group status

| Parameter  | Type | Description             |
|------------|------|-------------------------|
| group_name | Word | Name of failover group. |

#### Example

```
show failover group <group_name>
```

```
Group Status: Ready
  Last Change: Tue Oct 16 10:43:19 2012 UTC
  Associated Elements:
  Type Identifier Status
```

```
-----  
interface em0 carp 1 Active  
interface po1 carp 1 Standby
```

**show failover group brief**

Group Status Last Change

```
-----  
fg1 Ready Tue Oct 16 10:43:19 2012 UTC
```

**Related**

[Failover Mode Commands](#)

REST API Reference - [failover](#)



---

## Show Forward Proxy Commands

1. [show forward proxy](#)

---

### show forward proxy

#### Use

Use to display information and statistics about a forward proxy.

#### Default Setting

None

#### Command Mode

exec

#### Syntax

```
show forward-proxy <fp_name>
```

Shows information about forward-proxy objects

```
show forward-proxy <fp_name> statistics
```

Shows statistics related to a forward-proxy

```
show forward-proxy <fp_name> statistics detailed
```

Shows all detailed statistics related to a forward-proxy

```
show forward-proxy <fp_name> statistics http-requests
```

Shows forward-proxy http request statistics

```
show forward-proxy <fp_name> statistics http-response-codes
```

Shows forward-proxy http response-code statistics

```
show forward-proxy <fp_name> statistics http-responses
```

Shows forward-proxy http response statistics

## show forward-proxy brief

Show summary of forward-proxy status

| Parameter | Type | Description                                     |
|-----------|------|---|
| fp_name   | Word | Show information about a specific forward-proxy |

## Examples

### show forward-proxy fp1

Configuration

Admin Status: online  
Description:  
Mode: transparent  
Service Type: http  
Virtual IPs:

| Name         | Address                   | Port | Svc  | Admin  |
|--------------|---------------------------|------|------|--------|
| vipInternet1 | 0.0.0.0-9.255.255.255     | 80   | http | online |
| vipInternet2 | 11.0.0.0-192.0.2.9        | 80   | http | online |
| vipInternet3 | 192.0.2.11-255.25.255.255 | 80   | http | online |

HTTP Configuration

Keepalive Timeout: 10 s  
Response Timeout: 5 s  
Response Idle Timeout: 0 s  
Request Idle Timeout: 0 s

IP Configuration

DSCP to Client: <UNSET>  
DSCP to Server: <UNSET>

### show forward-proxy fp1 statistics

HTTP Requests (Termination Side)

Total: 0  
Request Rate: 0 requests/sec  
Total errors: 0  
Over Licensed Rate Limit: 0  
Over Licensed Rate Limit Rate: 0 requests/sec  
Requests Over Rate Limit: 0  
Requests Over Rate Limit Rate: 0 requests/sec  
Scripting fastPipe Error: 0

HTTP Responses (Termination Side)

Total: 0

|   |                 |
|---|-----------------|
| Timed Out:                                | 0               |
| Idle Timed Out:                           | 0               |
| LB Forbidden:                             | 0               |
| LB 5xx Error:                             | 0               |
| Over Rate Limit 503 Error:                | 0               |
| Over Rate Limit 503 Error Rate:           | 0 responses/sec |
| Script Request Timeout 504 Error:         | 0               |
| Script Request Timeout 504 Error Rate:    | 0 responses/sec |
| Scripting fastPipe Error:                 | 0               |
| Client Latency                            |                 |
| Transaction:                              | 0 s             |
| HTTP Requests (Initiation Side)           |                 |
| Request Rate:                             | 0 requests/sec  |
| Total:                                    | 0               |
| Total Queue Size:                         | 0               |
| Scripting fastPipe Error:                 | 0               |
| HTTP Responses (Initiation Side)          |                 |
| Total:                                    | 0               |
| Errored:                                  | 0               |
| Scripting fastPipe Error:                 | 0               |
| Request-redirects sent via scripting:     | 0               |
| Request-redirects received via scripting: | 0               |
| Server Latency                            |                 |
| Transaction:                              | 0 s             |
| Connect Tunnels                           |                 |
| Open:                                     | 0               |
| Opened Rate:                              | 0 tunnels/sec   |

**show forward-proxy fp1 statistics detailed**

|                                  |                |
|----------------------------------|----------------|
| HTTP Requests (Termination Side) |                |
| Total:                           | 0              |
| Request Rate:                    | 0 requests/sec |
| 1 Min Average:                   | 0 requests/sec |
| 5 Min Average:                   | 0 requests/sec |
| Good:                            | 0              |
| Timed Out:                       | 0              |
| Total errors:                    | 0              |
| Over Licensed Rate Limit:        | 0              |
| Over Licensed Rate Limit Rate:   | 0 requests/sec |
| 1 Min Average:                   | 0 requests/sec |
| 5 Min Average:                   | 0 requests/sec |
| Requests Over Rate Limit:        | 0              |
| Requests Over Rate Limit Rate:   | 0 requests/sec |

```

Scripting fastPipe Error: 0
HTTP Responses (Termination Side)
Total: 0
Timed Out: 0
Idle Timed Out: 0
LB Forbidden: 0
LB 5xx Error: 0
LB 5xx Error Rate: 0 errors/sec
  1 Min Average: 0 errors/sec
  5 Min Average: 0 errors/sec
Over Rate Limit 503 Error: 0
Over Rate Limit 503 Error Rate: 0 responses/sec
Script Request Timeout 504 Error: 0
Script Request Timeout 504 Error Rate: 0 responses/sec
Scripting dropped requests: 0
Scripting Uncaught Exceptions: 0
Scripting fastPipe Error: 0
Request Unknown Exceptions: 0
Client Latency
Transaction: 0 s
  1 Min Average: 0 s
  5 Min Average: 0 s

```

...

**show forward-proxy <fp\_name> statistics http-requests**

```

HTTP Requests (Termination Side)
Total: 0
Request Rate: 0 requests/sec
  1 Min Average: 0 requests/sec
  5 Min Average: 0 requests/sec
Good: 0
Timed Out: 0
Total errors: 0
Over Licensed Rate Limit: 0
Over Licensed Rate Limit Rate: 0 requests/sec
  1 Min Average: 0 requests/sec
  5 Min Average: 0 requests/sec
Requests Over Rate Limit: 0
Requests Over Rate Limit Rate: 0 requests/sec
Scripting fastPipe Error: 0
HTTP Requests (Initiation Side)

```

```

Request Rate:                0 requests/sec
  1 Min Average:            0 requests/sec
  5 Min Average:            0 requests/sec
Total:                        0
Abandoned:                  0
Total Queue Size:           0
  1 Min Average:            0
  5 Min Average:            0
Request Mgr Q Size:         0
  1 Min Average:            0
  5 Min Average:            0
Server Q Size:              0
  1 Min Average:            0
  5 Min Average:            0
Timed Out:                  0
Scripting fastPipe Error:   0

```

**show forward-proxy <fp\_name> statistics http-response-codes**

| HTTP Response Codes (Initiation Side) | Count | % of total count |
|---------------------------------------|-------|------------------|
| 100:                                  | 0     | 0                |
| 101:                                  | 0     | 0                |
| 102-199:                              | 0     | 0                |
| 200:                                  | 0     | 0                |
| 201:                                  | 0     | 0                |
| 202:                                  | 0     | 0                |
| 203:                                  | 0     | 0                |
| 204:                                  | 0     | 0                |
| 205:                                  | 0     | 0                |
| 206:                                  | 0     | 0                |
| 207-299:                              | 0     | 0                |
| 300:                                  | 0     | 0                |

...

**show forward-proxy <fp\_name> statistics http-responses**

| HTTP Responses (Termination Side) |   |
|-----------------------------------|---|
| Total:                            | 0 |
| Timed Out:                        | 0 |
| Idle Timed Out:                   | 0 |
| LB Forbidden:                     | 0 |

```

LB 5xx Error: 0
LB 5xx Error Rate: 0 errors/sec
  1 Min Average: 0 errors/sec
  5 Min Average: 0 errors/sec
Over Rate Limit 503 Error: 0
Over Rate Limit 503 Error Rate: 0 responses/sec
Script Request Timeout 504 Error: 0
Script Request Timeout 504 Error Rate: 0 responses/sec
Scripting dropped requests: 0
Scripting Uncaught Exceptions: 0
Scripting fastPipe Error: 0
Request Unknown Exceptions: 0
HTTP Responses (Initiation Side)
Response Rate: 0 responses/sec
  1 Min Average: 0 responses/sec
  5 Min Average: 0 responses/sec
Total: 0
Good: 0
Errored: 0
Extraneous: 0
Abandoned: 0
Timed Out: 0
Idle Timed Out: 0
Error receiving body: 0
Scripting fastPipe Error: 0

```

**show forward-proxy brief**

```

Name  Svc  Req/sec  Admin
-----
fp1   http  0         online

```

**Related**

[Forward Proxy Mode Commands](#)

REST API Reference - [forwardProxy](#)

---

## Show History Commands

1. [show history](#)

---

### show history

#### Use

Use to view the history of your last 800 CLI commands.

#### Default Setting

None

#### Command Mode

exec

#### Syntax

```
show history
```

Show command history

#### Example

```
show history
```

```
1  conf
2  virtual-server vs1
3  service http
4  persist cookie test expires
5  health-monitor hm2
6  real-server rs1
7  show real-server rs1
8  attach hm2
9  attach health-monitor hm2
10 show backup list
11 backup 2.2Test
```

- 12 show backup list
- 13 show backup list detailed



---

## Show Interfaces Commands

---

### show interfaces

#### Use

Use to show information about your interface settings.

#### Default Setting

None

#### Command Mode

exec

#### Syntax

```
show interfaces
```

Show configuration and statistics for all interfaces on the system

```
show interfaces <intf>
```

Show configuration and statistics for the specified interface

| Parameter | Type   | Description           |
|-----------|--------|-----------------------|
| intf      | String | Name of an interface. |

#### Example

```
show interfaces
```

```
em0 is up, line protocol is up
  Hardware is Intel82540EM, address is 0800.276b.2aed
  Internet address is 10.0.2.15/24, broadcast is 10.0.2.255 (static)
  Internet address is 192.0.2.10/24, broadcast is 192.0.2.255 (dhcp)
    DHCP Lease expires at 05/17/2014 07:49:56
  MTU 1500 bytes, BW 1000000 Kbit
  Full-duplex, 1 Gb/s, auto-negotiation: on
    279243 packets input, 16761872 bytes
```

```
Received 279084 multicast
0 input errors
0 packets dropped
5963 packets output, 454176 bytes
Sent 0 multicast/broadcast
0 output errors
em1 is up, line protocol is up
Hardware is Intel82540EM, address is 0800.2751.4100
MTU 1500 bytes, BW 1000000 Kbit
Full-duplex, 1 Gb/s, auto-negotiation: on
6242 packets input, 608720 bytes
Received 6242 multicast
0 input errors
0 packets dropped
0 packets output, 0 bytes
Sent 0 multicast/broadcast
0 output errors
```

### **show interface em0**

```
em0 is up, line protocol is up
Hardware is Intel82540EM, address is 0800.276b.2aed
Internet address is 10.0.2.15/24, broadcast is 10.0.2.255 (static)
Internet address is 192.0.2.10/24, broadcast is 192.0.2.255 (dhcp)
DHCP Lease expires at 05/17/2014 07:49:56
MTU 1500 bytes, BW 1000000 Kbit
Full-duplex, 1 Gb/s, auto-negotiation: on
298636 packets input, 17926166 bytes
Received 298440 multicast
0 input errors
0 packets dropped
6375 packets output, 487768 bytes
Sent 0 multicast/broadcast
0 output errors
```

### **Related**

CLI Reference - [Interface Mode Commands](#)

CLI Reference - [Show LACP Commands](#)

CLI Reference - [Show Port Channel Mode Commands](#)

REST API Reference - [interface](#)

---

## Show IP Commands

1. [show ip](#)
2. [show ipv6](#)
3. [show ip dhcp](#)
4. [show ip dns](#)
5. [show ip filter-list](#)

---

## show ip

Display IPv4-related settings.

### Use

This command has the following uses for IPv4:

- To see the status and configuration of interfaces.
- To see IP routes.
  - A connected route (C) is one the system automatically adds based on the interface IP address.
  - A static route (S) is one you created using the ip route command.
  - The detail form of IP routes includes additional internal details about the routing table that you can use for troubleshooting. For example, the detail includes ARP entries.
- To see IP traffic counters. These counters are helpful for network troubleshooting. In general, if a counter increases at an unusual rate, you should determine why. Some increases may reflect hacking attempts. Below are a few key counters and their descriptions:
  - IP statistics
    - Rcvd
      - First line (totals and local destinations)—Normal to have very high numbers.
      - All other counters—If a counter increases at an unusual rate, you should determine why. Some increases may reflect hacking attempts.
    - Frags
      - reassembled, fragmented, fragments—Normal to see these increase at a high rate.
      - timeouts—Normal to increase, but not as rapidly as the counters mentioned above.
    - Sent
      - First line (generated and forwarded)—Normal to have very high numbers.
      - no route—Indicates a configuration problem with the system or with a gateway. The system does not have a route for a destination. Check the system default route.

- insufficient buffers—If this increases at an unusual rate, the system is overloaded.
- ICMP statistics
  - Rcvd
    - unreachable—Normal to have a high number. The system receives unreachable errors when the system tries to send a large packet to a client or real server and a gateway cannot accept a packet that large or when the real server does not have the correct port set to accept connections.
    - echo and echo reply—Reflect ping commands. If this number increases at an unusual rate, it could be mean someone is trying to hack the system.
  - Sent
    - echo and echo reply—Reflect ping commands.

## Default Setting

None

## Command Mode

exec

## Syntax

`show ip interface brief`

Show a status summary of IP interfaces

`show ip route [detailed]`

Show IPv4 routing information

`show ip traffic`

IPv4 protocol statistics

## Related Commands

[Interface Mode Commands](#)

[IP Route Example](#)

REST API Reference - [ip](#)

## Examples

`show ip interface brief`

```

Interface  IP Address      Status  Protocol
-----
```

```
em0      10.190.5.45/21  up      up
lo0      ::1/128         up      unknown
lo0      127.0.0.1/8    up      unknown
```

### show ip route

Codes: C - connected, S - static

Gateway of last resort is 10.190.0.1 to network 0.0.0.0

```
S    0.0.0.0/0 via 10.190.0.1, em0, MTU 1500
C    10.190.0.0/21 is directly connected, em0, MTU 1500
SC   10.190.5.45/32 is directly connected, lo0, MTU 16384
```

### show ip traffic

IP statistics:

```
Rcvd: 513959 total, 512600 local destination
      0 format errors, 0 checksum errors, 0 bad hop count
      1338 unknown protocol, 21 not a gateway
      0 security failures, 0 bad options, 0 with options
Frag: 0 reassembled, 0 timeouts, 0 couldn't reassemble
      0 fragmented, 0 fragments, 0 couldn't fragment
Sent: 460888 generated, 0 forwarded
      0 no route, 0 unicast RPF, 0 forced drop
      0 options denied
Drop: 0 insufficient buffers
Drop: 0 packets with internal loop back IP address
```

ICMP statistics:

```
Rcvd: 0 format errors, 0 checksum errors, 0 redirects, 0 unreachable
      0 echo, 0 echo reply, 0 mask requests, 0 mask replies, 0 quench
      0 parameter, 0 timestamp, 0 timestamp replies, 0 info request, 0 other
      0 irdp solicitations, 0 irdp advertisements
      0 info reply, 0 time exceeded, 0 traceroute
Sent: 0 redirects, 0 unreachable, 0 echo, 0 echo reply
      0 mask requests, 0 mask replies, 0 quench, 0 timestamp, 0 timestamp replies
      0 info reply, 0 time exceeded, 0 parameter problem, 0 other
      0 irdp solicitations, 0 irdp advertisements
      0 info request, 0 traceroute
```

---

## show ipv6

Use

This command has the following uses:

- To see IPv6 routes.
  - A connected route (C) is one the system automatically adds based on the interface IP address.
  - A static route (S) is one you created using the ip route command.
  - The detail of IP routes includes additional internal details about the routing table that you can use for troubleshooting. For example, the detail includes ARP entries.
- To see IPv6 traffic counters. These counters are helpful for network troubleshooting. In general, if a counter increases at an unusual rate, you should determine why. Some increases may reflect hacking attempts. Below are a few key counters and their descriptions:
  - IP statistics
    - Rcvd
      - First line (totals and local destinations)—Normal to have very high numbers.
      - All other counters—If a counter increases at an unusual rate, you should determine why. Some increases may reflect hacking attempts.
    - Frags
      - reassembled, fragmented, fragments—Normal to see these increase at a high rate.
      - timeouts—Normal to increase, but not as rapidly as the counters mentioned above.
    - Sent
      - First line (generated and forwarded)—Normal to have very high numbers.
      - no route—Indicates a configuration problem with the system or with a gateway. The system does not have a route for a destination. Check the system default route.
      - insufficient buffers—If this increases at an unusual rate, the system is overloaded.
  - ICMP statistics
    - Rcvd
      - unreachable—Normal to have a high number. The system receives unreachable errors when the system tries to send a large packet to a client or real server and a gateway cannot accept a packet that large or when the real server does not have the correct port set to accept connections.
      - echo and echo reply—Reflect ping commands. If this number increases at an unusual rate, it could be mean someone is trying to hack the system.
    - Sent
      - echo and echo reply—Reflect ping commands.

## Default Setting

None

## Command Mode

exec

## Syntax

```
show ipv6 route [detailed]
```

Show IPv6 routing information

```
show ipv6 traffic
```

IPv6 protocol statistics

### Related Commands

CLI Reference - [Interface Mode Commands](#)

REST API Reference - [ip](#)

---

## show ip dhcp

### Use

Use to display the all known DHCP information.

Below are the possible values for the state field or node:

- disabled - DHCP not enabled.
- starting - DHCP enabled, dhclient not yet started.
- requesting - dhclient has been started or restarted.
- enabled - DHCP lease has been acquired.
- expired - DHCP lease has expired and attempts to renew have failed.
- no server - Unable to contact a DHCP server.

### Default Setting

None

### Command Mode

exec

### Syntax

```
show ip dhcp
```

Show DHCP information

```
show ip dhcp em0
```

Show DHCP information for the specified interface

### Example

```
show ip dhcp
```

```
Interface em0
```

```
    State:                enabled
```

|                       |                     |          |
|-----------------------|---------------------|----------|
| IP Address:           | 192.0.2.10          | active   |
| Netmask:              | 255.255.255.0       | active   |
| Broadcast:            | 192.0.2.255         | active   |
| Lease Time (seconds): | 86400               | active   |
| Lease Expiration:     | 05/17/2014 07:49:56 | active   |
| Host Name:            | <UNSET>             | inactive |
| Server:               | 10.0.2.2            | active   |
| Default Route:        | 10.0.2.1            | inactive |
| Domain Name:          | home.network        | inactive |
| Name Server:          | 75.75.75.75         | inactive |
| Name Server:          | 75.75.76.76         | inactive |

### Related Commands

CLI Reference - [ip address dhcp](#)

REST API Reference - [dhcp](#)

---

## show ip dns

### Use

Use to display the configured DNS settings.

### Default Setting

None

### Command Mode

exec

### Syntax

**show ip dns**

Show dns information

### Example

**show ip dns**

```
Configuration
Name Servers: 198.51.100.25
Search Domains: int.f5.com
Timeout (seconds): <default> (3)
```



Retries: <default> (1)  
Admin Status: online

## Related Commands

CLI Reference - [ip dns](#)

REST API Reference - [ip](#)

---

# show ip filter-list

## Use

Use to display information about the filter list.

To see the actual rules in the filter list, use `show run`.

## Default Setting

None

## Command Mode

exec

## Syntax

```
show ip filter-list [filter_name]
```

Display information about the specified ip filter list

| Parameter   | Type | Description                |
|-------------|------|----------------------------|
| filter_name | Word | Name of the IP filter list |

## Related Commands

CLI Reference - [ip filter-list](#)

CLI Reference - [virtual-ip attach ip-filter](#)

REST API Reference - [connFilter](#)

---

## Show LACP Commands

1. [show lacp](#)

---

### show lacp

#### Use

Use to show LACP settings on port channels configured to use LACP.

#### Default Setting

None

#### Command Mode

exec

#### Syntax

```
show lacp
```

Show the status of LACP port channels

```
show lacp <chan_num>
```

Show the status of LACP port channels

```
show lacp <chan_num> internal
```

Show information about the local LACP state

```
show lacp <chan_num> neighbor
```

Show information about the neighbor LACP state

```
show lacp internal
```

Show information about the local LACP state

```
show lacp neighbor
```

Show information about the neighbor LACP state

| Parameter | Type    | Description   |
|-----------|---------|---|
| chan_num  | Integer | Port channel number. Use only the number. For example, <code>show lacp 1</code> . |

## Example

### `show lacp`

State codes:

A = Active P = Passive  
S = Short Timeout L = Long Timeout  
G = Aggregatable I = Individual  
+ = In Sync - = Out of Sync

C = Collecting

D = Distributing  
! = Using default for peer  
X = Timeout Expired

Port Channel 1:

```
Intf Peer | Port SysId Key Priority State
```

```
-----
em1 Internal | 2 8000,08-00-27-D8-0E-D4 0x00F0 32768 ALG+CD (!)
em1 Neighbor | 0 FFFF,00-00-00-00-00-00 0x0000 65535 PLG+CD
```

Port Channel 2:

```
Intf Peer | Port SysId Key Priority State
```

[This port channel is configured to use "on" (static) mode.]

### `show lacp 1`

State codes:

A = Active P = Passive  
S = Short Timeout L = Long Timeout  
G = Aggregatable I = Individual  
+ = In Sync - = Out of Sync

C = Collecting

D = Distributing  
! = Using default for peer  
X = Timeout Expired

Port Channel 1:

```
Intf Peer | Port SysId Key Priority State
```

```
-----
em1 Internal | 2 8000,08-00-27-D8-0E-D4 0x00F0 32768 ALG+CD (!)
em1 Neighbor | 0 FFFF,00-00-00-00-00-00 0x0000 65535 PLG+CD
```

## show lacp 1 internal

State codes:

A = Active P = Passive  
S = Short Timeout L = Long Timeout  
G = Aggregatable I = Individual  
+ = In Sync - = Out of Sync

C = Collecting

D = Distributing  
! = Using default for peer  
X = Timeout Expired

Port Channel 1:

| Intf | Port | SysId | Key | Priority | State |
|------|------|-------|-----|----------|-------|
|------|------|-------|-----|----------|-------|

|     |   |                        |        |       |            |
|-----|---|------------------------|--------|-------|------------|
| em1 | 2 | 8000,08-00-27-D8-0E-D4 | 0x00F0 | 32768 | ALG+CD (!) |
|-----|---|------------------------|--------|-------|------------|

## show lacp 1 neighbor

Port Channel 1:

| Intf | Port | SysId | Key | Priority | State |
|------|------|-------|-----|----------|-------|
|------|------|-------|-----|----------|-------|

|     |   |                        |        |       |        |
|-----|---|------------------------|--------|-------|--------|
| em1 | 0 | FFFF,00-00-00-00-00-00 | 0x0000 | 65535 | PLG+CD |
|-----|---|------------------------|--------|-------|--------|

## Related

[Show Interfaces Commands](#)

[Show Port Channel Mode Commands](#)

REST API Reference - [channelPorts](#)

## Show Licensing Commands

1. [show licensing](#)

### show licensing

#### Use

Use to display licensing information.

Use the `show licensing dossier` command or the `/status/app/licensing/dossier` node to generate a dossier after entering your registration key, then use the dossier at <https://activate.f5.com> to activate your license. The system generates a new dossier each time you run the command or access the node.

The State field of the `show licensing detailed` and `show licensing feature <feature>` commands and the `/status/app/licensing/feature/base/status` REST node, shows one of the states described in the table below.

| State                                    | Meaning  | Possible causes  | What to do  |
|--|--|--|---|
| license server communication in progress | The system is currently contacting the license server to retrieve the license.               | License is currently being retrieved from the license server.  | This is not an error.   |
| running                                  | License is installed and active. This is the normal, good state.                             | N/A  | N/A   |
| not configured                           | License is not fully configured.   | License was never configured or configuration is not complete.   | See <a href="#">Configuring Licensing</a> .   |
| No license exists for feature <feature>  | The named featured does not have an active license.  | License was never configured or configuration is not complete.   | See <a href="#">Configuring Licensing</a> .   |
| No bundle uploaded                       | Applies to Starter Edition only. The phone home bundle was not uploaded when last scheduled. | <ul style="list-style-type: none"> <li>• Phone home credentials are not properly configured.</li> <li>• System has lost connectivity with</li> </ul> | <ul style="list-style-type: none"> <li>• See <a href="#">Configuring Licensing</a>.</li> <li>• See <a href="#">Troubleshooting</a></li> </ul> |

| State   | Meaning  | Possible causes   | What to do   |
|---|--|---|--|
|   |  | api.f5.com and asb.f5.com or both.  | <a href="#">Licensing for Version 2.6.1.</a>   |
| No phone-home credentials configured                                | Applies to Starter Edition only. The phone home login and password required for the Starter Edition are not configured properly. | Either the phone home credentials are not configured or they are not correct.             | Configure the phone home credentials. See <a href="#">Phone Home Mode Commands</a> .   |
| Failed to upload bundle: <some error="error" condition="condition"> | Applies to Starter Edition only. Some condition did not permit upload of the phone home bundle.                                  | The details of the error condition outline the cause.                                     | Based on the details of the error conditions, resolve the situation. Common conditions are DNS failure or route failure.             |
| Error parsing license   | License content is not complete or is corrupted.   | License file or copy/paste text is incomplete or corrupted.                               | Download or paste the license again. See <a href="#">Configuring Licensing</a> .   |
| License is incomplete. Missing fields: <field names="names">        | License content is not complete or is corrupted.   | License file or copy/paste text is incomplete or corrupted.                               | Download or paste the license again. See <a href="#">Configuring Licensing</a> .   |
| License contains incorrect username                                 | Applies to Starter Edition only. F5 username or password for phone home configuration is not correct.                            | Typing error when entering the F5 username or password when configuring phone home.       | Configure phone home with the correct username and password. See <a href="#">Phone Home Mode Commands</a> .                          |
| License contains incorrect system UUID                              | License and hardware UUIDs do not match.   | License information was generated for different hardware.                                 | Reconfigure the license, making sure you use the same hardware for the entire procedure. See <a href="#">Configuring Licensing</a> . |
| License contains incorrect feature                                  | This license is probably not for F5 <sup>®</sup> LineRate <sup>®</sup> .   | Incorrect license installed.  | Reconfigure the license, using the F5 <sup>®</sup> LineRate <sup>®</sup> license. See <a href="#">Configuring Licensing</a> .        |
| License is expired  | The license payment did not process correctly, and the license grace period has elapsed.   | Payment did not get processed, because the credit card was declined. It could be declined | <ul style="list-style-type: none"> <li>Reconfigure the license, using the <code>{{lbproduct}}</code> license.</li> </ul>             |

| State  | Meaning  | Possible causes   | What to do  |
|--|--|---|---|
|  |  | because the account was closed or the card expired.   | <p>See <a href="#">Configuring Licensing</a>.</p> <ul style="list-style-type: none"> <li>You may need to update your payment information for your subscription.</li> <li>You may need to pay for the last renewal period.</li> </ul>  |
| License is expired. Bundle upload has not occurred | Applies to Starter Edition and paid tiers when paid license has expired. The phone home bundle was not uploaded when last scheduled. | <ul style="list-style-type: none"> <li>Phone home credentials are not properly configured.</li> <li>System has lost connectivity with api.f5.com and asb.f5.com or both.</li> </ul>                   | <ul style="list-style-type: none"> <li>See <a href="#">Configuring Licensing</a>.</li> <li>See <a href="#">Troubleshooting Licensing for Version 2.6.1</a>.</li> </ul>  |
| License is incomplete. Missing dossier             | License is invalid.  | <ul style="list-style-type: none"> <li>Possibly out-of-memory situation.</li> <li>Possibly BIOS UUID or DMI is disabled. It is required that BIOS UUID is enabled.</li> </ul>                         | <ol style="list-style-type: none"> <li>Resolve any out-of-memory situation.</li> <li>Check the BIOS configuration to make sure UUID is enabled.</li> <li>Reconfigure licensing. See <a href="#">Configuring Licensing</a>.</li> </ol> |
| Failed to create dossier hash. Unable to validate  | Dossier did not generate properly.   | <ul style="list-style-type: none"> <li>License information was generated for different hardware.</li> <li>Possibly BIOS UUID or DMI is disabled. It is required that BIOS UUID is enabled.</li> </ul> | Reconfigure licensing. See <a href="#">Configuring Licensing</a> .  |
| License dossier does not match system dossier      | Dossier in the license and on the system do not match.   | Dossier in the license file did not come from the same system where the license was installed.  | Generate the dossier and install the license using the same system. See <a href="#">Configuring Licensing</a> .   |

| State  | Meaning   | Possible causes   | What to do   |
|--|---|---|--|
| Unable to process license. No license version found      | License is invalid.                                 | License installed was not a valid format.                           | Reconfigure licensing. See <a href="#">Configuring Licensing</a> .                                     |
| Unable to process license. License format not compatible | The version of the license format is not supported. | The license is for a system that has a different version installed. | Reconfigure licensing using the same system for all steps. See <a href="#">Configuring Licensing</a> . |

### Default Setting

None

### Command Mode

exec

### Syntax

**show licensing activation**

Show the license activation mode (auto or manual)

**show licensing brief**

Show summary of all licenses

**show licensing detailed**

Show details of all licenses

**show licensing dossier**

Show the system dossier

**show licensing feature base**

Show details of base license

**show licensing feature base detailed**

Show details of the base license

**show licensing host-id**



Display host ID information

**show licensing host-id detailed**

Not used

**show licensing host-id xml**

Not used

**show licensing regkey**

Show configured regkey

**show licensing statistics**

Show statistics for licensed rate limits

## Examples

**show license activation**

auto

**show licensing brief**

RegKey: A41158-38673-55555-5555-55555555

| Feature    | Status  | Expiration                  | HTTP Req/s Limit | TCP Conn/s Limit |
|------------|---------|-----------------------------|------------------|------------------|
| Mbps Limit | Burst   | Duration (sec)              | Process Limit    | Phone Home       |
| base       | active  | 06/20/2014 23:59:59         | 100              | 10               |
| 10         | 1       | unlimited                   | off              |                  |
| base       | standby | 14 days after bundle upload | 3                | 2                |
| 5          | 60      | 1                           | on               |                  |

INFO: Automatic license renewal enabled.

**show licensing detailed**

RegKey: A41158-38673-55555-5555-55555555

base:

State: running

Status: active

Expiration: 06/20/2014 23:59:59

Username: n/a

Version: 5b

UUID: 564D5DD4-C009-8BA6-4177-1E5FB67FED9E

HTTP Requests Per Sec: 100  
TCP Connections Per Sec: 10  
Mb Per Sec: 10  
Burst Duration (sec): 1  
Processes: unlimited  
Phone Home: off  
Standby:  
Free Status: standby  
Free Expiration: 14 days after bundle upload  
Free Username: n/a  
Free Version: 5b  
Free UUID: 564D5DD4-C009-8BA6-4177-1E5FB67FED9E  
Free HTTP Requests Per Min: 180  
Free TCP Connections Per Min: 120  
Free Mb Per Sec: 5  
Free Burst Duration (min): 1  
Free Processes: 1  
Free Phone Home: on  
INFO: Automatic license renewal enabled.

**show licensing dossier**

b066d441d044fc093bc487d20c1b9d0160e410f773a8e9f031087b1a49783728c7561bf2e9bc10dd8854b51a3e5c06

**show licensing feature base**

State: running  
Status: active  
Expiration: 06/20/2014 23:59:59  
Username: n/a  
Version: 5b  
UUID: 564D5DD4-C009-8BA6-4177-1E5FB67FED9E  
HTTP Requests Per Sec: 100  
TCP Connections Per Sec: 10  
Mb Per Sec: 10  
Burst Duration (sec): 1  
Processes: unlimited  
Phone Home: off  
Standby:  
Free Status: standby  
Free Expiration: 14 days after bundle upload  
Free Username: n/a  
Free Version: 5b  
Free UUID: 564D5DD4-C009-8BA6-4177-1E5FB67FED9E

Free HTTP Requests Per Min: 180  
Free TCP Connections Per Min: 120  
Free Mb Per Sec: 5  
Free Burst Duration (min): 1  
Free Processes: 1  
Free Phone Home: on

**show licensing feature base detailed**

State: running  
Status: active  
Expiration: 06/20/2014 23:59:59  
Username: n/a  
Version: 5b  
UUID: 564D5DD4-C009-8BA6-4177-1E5FB67FED9E  
HTTP Requests Per Sec: 100  
TCP Connections Per Sec: 10  
Mb Per Sec: 10  
Burst Duration (sec): 1  
Processes: unlimited  
Phone Home: off  
Standby:  
Free Status: standby  
Free Expiration: 14 days after bundle upload  
Free Username: n/a  
Free Version: 5b  
Free UUID: 564D5DD4-C009-8BA6-4177-1E5FB67FED9E  
Free HTTP Requests Per Min: 180  
Free TCP Connections Per Min: 120  
Free Mb Per Sec: 5  
Free Burst Duration (min): 1  
Free Processes: 1  
Free Phone Home: on

base license contents:

```
#  
Auth vers :                               5b  
#  
#      Linerate Product License File  
#      DO NOT EDIT THIS FILE!!  
#  
#      Technical Support:  
#      Web                tech.f5.com  
#      Phone              (206) 272.6888
```

```
# Fax (206) 272.6802
# Email (support) support@f5.com
# AskF5 askf5@f5.com
#
# Only the specific use referenced above is allowed. Any other uses are prohibited.
#
#
# Warning: Changing the system time while this system is running
# with a time-limited license may make the system unusable.
#
Usage : F5 Internal Product Development
#
#
# Only the specific use referenced above is allowed. Any other uses are prohibited.
#
Vendor : F5 Networks, Inc.
#
# Module List
#
active module : LineRate, Base|P493547-9436451
timelimited module : LineRate, 10M Yearly,
StoreFront|K857383-2143406|20140521|20140620|SUBSCRIPTION
optional module : LineRate, 1000M Monthly, StoreFront
optional module : LineRate, 1000M Yearly, StoreFront
optional module : LineRate, 100M Monthly, StoreFront
optional module : LineRate, 100M Yearly, StoreFront
optional module : LineRate, 10M Monthly, StoreFront
optional module : LineRate, 250M Monthly, StoreFront
optional module : LineRate, 250M Yearly, StoreFront
optional module : LineRate, 5000M Monthly, StoreFront
optional module : LineRate, 5000M Yearly, StoreFront
optional module : LineRate, 500M Monthly, StoreFront
optional module : LineRate, 500M Yearly, StoreFront
optional module : LineRate, 50M Monthly, StoreFront
optional module : LineRate, 50M Yearly, StoreFront
#
# Accumulated Tokens for Module
# 1 20140620_bandwidth_per_second 10 key K857383-2143406
#
# Accumulated Tokens for Module
# 1 20140620_billing_grace_period 14 key K857383-2143406
#
# Accumulated Tokens for Module
```

```

#       1 20140620_burst_duration 1 key K857383-2143406
#
#       Accumulated Tokens for Module
#       1 20140620_http_requests_per_second 100 key K857383-2143406
#
#       Accumulated Tokens for Module
#       1 20140620_tcp_connections_per_second 10 key K857383-2143406
#
20140620_bandwidth_per_second :      10
20140620_billing_grace_period :      14
20140620_burst_duration :           1
20140620_http_requests_per_second :  100
20140620_tcp_connections_per_second :  10
#
#       Accumulated Tokens for Module
#       LineRate, Base free_bandwidth_per_second 5 key P493547-9436451
#
#       Accumulated Tokens for Module
#       LineRate, Base free_burst_duration 60 key P493547-9436451
#
#       Accumulated Tokens for Module
#       LineRate, Base free_expiration 14 key P493547-9436451
#
#       Accumulated Tokens for Module
#       LineRate, Base free_http_requests_per_second 3 key P493547-9436451
#
#       Accumulated Tokens for Module
#       LineRate, Base free_tcp_connections_per_second 2 key P493547-9436451
#
free_bandwidth_per_second :      5
free_burst_duration :           60
free_expiration :               14
free_http_requests_per_second :  3
free_tcp_connections_per_second :  2
#
#       License Tokens for Module LineRate, Base key P493547-9436451
mod_lros :                      enabled
license_recycle :                enabled
free_cpu_cores :                 1
Exclusive_Platform :             LineRate
#
#       License Tokens for on Base Key A41158-38673-55117-7375-2856403
#

```

```

20140620_subscr_purchased :          345759920
20140620_cpu_cores :                UNLIMITED
#
#      Licensing Information
#
Licensed date :                      20140521
License start :                      20140520
License end :                        20140621
Service check date :                20140521
#
#      Platform Information
#
Registration Key :                   A41158-38673-55117-7375-2856403
Licensed version :                   0.0.0
Platform ID :                       Linerate
#
#      Outbound License Dossier Validation
#
Dossier :                            16a1ce0a8d6cc83be3030c2e5f34b01943
#
#      Outbound License Authorization Signature
#
Authorization :
cc70a3d7a45d199999999bd348aee154ef875537553b729a1645066666666666666913d2c707fa2e860976bafee7
#
#-----
# Copyright 1996-2014, F5 Networks, Inc.
# All rights reserved.
#-----
INFO: Automatic license renewal enabled.

```

**show licensing host-id**

2AEF8MWA-45BC-4B4E-953C-7A65B1F433333368

**show licensing regkey**

A41158-38673-55555-5555-55555555

**show licensing statistics**

| Limit Name   | Limit | 1 Sec Avg | 1 Min Avg | 5 Min Avg |
|--------------|-------|-----------|-----------|-----------|
| HTTP Req/Sec | 100   | 0         | 0         | 0         |

|              |    |   |   |   |
|--------------|----|---|---|---|
| TCP Conn/Sec | 10 | 0 | 0 | 0 |
| Mbps         | 10 | 0 | 0 | 0 |

## Related

CLI Reference - [Licensing Mode Commands](#)

REST API Reference - [licensing](#)

---

## Show Load Balancer Commands (Deprecated)

---



In F5® LineRate® version 2.0, the `show` load-balancer command is deprecated and is replaced by the [show proxy](#) command. The corresponding REST API nodes are not affected.

---

Use the following commands to display statistics for the load balancer.

---

### show load-balancer statistics

#### Use

Use to display statistics related to the load balancer, which includes combined, global statistics for the whole system.

The real server limits vary based on the amount of system RAM:

- Less than 48 GB memory—8,000 real servers.
- 48 GB memory or more—24,000 real servers.

The virtual IP limits vary based on the amount of system RAM:

- Less than 48 GB memory—2,000 VIPs.
- 48 GB memory or more—6,000 VIPs.

The virtual server limits vary based on the amount of system RAM:

- Less than 48 GB memory— 2,000 virtual servers.
- 48 GB memory or more—6,000 virtual servers.

The proxy limits vary based on the amount of system RAM:

- Less than 48 GB memory— 2,000 proxies.
- 48 GB memory or more—6,000 proxies.

#### Default Setting

None

#### Command Mode

exec



## Syntax

**show load-balancer statistics**

Display load balancer statistics

**show load-balancer statistics detailed**

Display detailed load balancer statistics

**show load-balancer limits**

Display load balancer limits; limits vary based on the amount of system RAM

## Examples

**show load-balancer statistics**

```
Load Balancer Clients
Open Connections: 0
Total Input Traffic (1 min avg): 0.000 bits/sec
Total Output Traffic (1 min avg): 0.000 bits/sec
SSL Input Traffic (1 min avg): 0.000 bits/sec
SSL Output Traffic (1 min avg): 0.000 bits/sec
New Connection Rate: 0 connections/sec
HTTP Request Rate: 0 requests/sec
Load Balancer Servers
Open Connections: 0
Input Traffic (1 min avg): 0.000 bits/sec
Output Traffic (1 min avg): 0.000 bits/sec
```

**show load-balancer statistics detailed**

```
eventLoopTime: 0.000000
eventLoopTime 1 Min Avg: 0.000000
eventLoopTime 5 Min Avg: 0.000000
keventTime: 0.000000
keventTime 1 Min Avg: 0.624966
keventTime 5 Min Avg: 0.624993
connClientOpen: 0
connClientReadSize: 0.000000
connClientReadSize 1 Min Avg: 0.000000
connClientReadSize 5 Min Avg: 0.000000
connClientWriteSize: 0.000000
connClientWriteSize 1 Min Avg: 0.000000
connClientWriteSize 5 Min Avg: 0.000000
connAcceptMax: 0.000000
connAcceptMax 1 Min Avg: 0.000000
connAcceptMax 5 Min Avg: 0.000000
connAccepted: 0.000000
connAccepted 1 Min Avg: 0.000000
connAccepted 5 Min Avg: 0.000000
connAcceptReportedAvail: 0.000000
connAcceptReportedAvail 1 Min Avg: 0.000000
connAcceptReportedAvail 5 Min Avg: 0.000000
```

```
httpClientRequestLatency: 0.000000
httpClientRequestLatency 1 Min Avg: 0.000000
httpClientRequestLatency 5 Min Avg: 0.000000
httpClientRespLatency: 0.000000
httpClientRespLatency 1 Min Avg: 0.000000
httpClientRespLatency 5 Min Avg: 0.000000
httpClientRespInitLatency: 0.000000
httpClientRespInitLatency 1 Min Avg: 0.000000
httpClientRespInitLatency 5 Min Avg: 0.000000
httpClientXactionLatency: 0.000000
httpClientXactionLatency 1 Min Avg: 0.000000
httpClientXactionLatency 5 Min Avg: 0.000000
connClientBytesRx: 0
connClientBytesRx/sec: 0
connClientBytesRx/sec 1 Min Avg: 0
connClientBytesRx/sec 5 Min Avg: 0
```

[Output continues with many additional lines of detail.]

#### **show load-balancer limits**

```
Maximum Virtual IPs: 2000
Maximum Virtual Servers: 2000
Maximum Real Servers: 8000
```

#### **Related**

CLI Reference - [Load Balancer Mode Commands](#)

REST API Reference - [stats](#)

REST API Reference - [limits](#)

---

## Show NTP Commands

1. [show ntp](#)

---

### show ntp

#### Use

Use the view the NTP servers configured in the system and information about each one.

#### Default Setting

None

#### Command Mode

exec

#### Syntax

```
show ntp
```

Shows the IP address of the configured NTP servers

#### Related

CLI Reference - [NTP Mode Commands](#)

REST API Reference - [ntp](#)

---

## Show Phone Home Commands

1. [show phone-home](#)

---

### show phone-home

#### Use

Use to display phone home configuration information. Use the redacted form to remove password details.

#### Default Setting

None

#### Command Mode

exec

#### Syntax

**show phone-home**

Shows phone home configuration with encrypted password

**show phone-home redacted**

Shows phone home configuration with XXXXX as the password

#### Example

```
LROS# show phone-home
Phone Home Status
  Status:                OK
  Error Timestamp:       n/a
  Next Upload Time:     n/a
Phone Home Configuration
  F5 Login URL:          https://api.f5.com/auth/pub/sso/login/iheatlh-api
  F5 Upload URL:         https://asb.f5.com/appsupport-analyzer/api/appsupport-bundles
  F5 Qkview URL:         https://ihealth.f5.com/linerate-analyzer/api/bundles
  Last Upload Time:     n/a
  F5 User Name:          user@f5.com
  F5 Password:           LU6N1BRsC+Hr1DGWekF0+w==
Amazon EC2 configuration
  Terms Accepted: <UNSET>
```

```
LROS# show phone-home redacted
Phone Home Status
  Status:                <redacted>
  Error Timestamp:       n/a
  Next Upload Time:     n/a
Phone Home Configuration
  F5 Login URL:          http://phoneHomeServer/
  F5 Upload URL:         http://phoneHomeServer/
  F5 Qkview URL:        https://ihealth.f5.com/linerate-analyzer/api/bundles
  Last Upload Time:     n/a
  F5 User Name:          jputrino@f5.com
  F5 Password:          <redacted>
Amazon EC2 configuration
  Terms Accepted: <UNSET>
```

## Related

[Phone Home Mode Commands](#)

---

## Show Port Channel Mode Commands

1. [show port-channel](#)
- 

### show port-channel

#### Use

Use to view the configuration of port channels.

The Status column shows the following:

- Inactive—This interface is not being used by the port channel. For example, it may be administratively down, the cable may be unplugged, or LACP may have negotiated that it not be used. See the Reason column in the CLI, or the reason REST node for this interface.
- Operational—This interface is being used by the port channel.

The Reason column shows the following:

|   |  |
|---|--|
| Unset                                     | The port channel's mode has not been set or does not match the rest of the interfaces in the port channel.               |
| Static                                    | The port channel's mode is set to "on."  |
| LACP                                      | The port channel's mode is set to "active," which means it is using LACP.  |
| Admin Status Up or<br>Admin Status Down   | The port channel's admin status is set to online or offline.   |
| Link Protocol Up or Link<br>Protocol Down | The connection to the port channel is not working for some hardware reason (cable disconnected, failed interface, etc.). |
| Unknown                                   | The system cannot determine the status of the port channel.  |

## Default Setting

None

## Command Mode

exec

## Syntax

```
show port-channel
```

Show the configured port channels

```
show port-channel <chan_num>
```

Show the configuration of the specified port channel

| Parameter | Type    | Description   |
|-----------|---------|---|
| chan_num  | Integer | Port channel number. Use only the number. For example, <code>show port-channel 1</code> . |

## Example

```
show port channel
```

Port Channel 1:

```
Port Protocol Mode Status Reason
```

```
-----
```

```
em1 LACP Active Operational LACP
```

Port Channel 2:

```
Port Protocol Mode Status Reason
```

```
-----
```

```
em2 Static On Operational Static
```

```
show port channel 1
```

Port Channel 1:

```
Port Protocol Mode Status Reason
```

```
-----
```

```
em1 LACP Active Operational LACP
```

## Related

[Show Interfaces Commands](#)

[Show LACP Commands](#)

REST API Reference - [channelPorts](#)



---

## Show Proxy Commands

1. [show proxy statistics](#)

Use the following commands to display statistics for the proxy.

---

### show proxy statistics

#### Use

Use to display statistics related to the proxy, which includes combined, global statistics for the whole system.

The real server limits vary based on the amount of system RAM:

- Less than 48 GB memory—8,000 real servers.
- 48 GB memory or more—24,000 real servers.

The virtual IP limits vary based on the amount of system RAM:

- Less than 48 GB memory—2,000 VIPs.
- 48 GB memory or more—6,000 VIPs.

The virtual server limits vary based on the amount of system RAM:

- Less than 48 GB memory— 2,000 virtual servers.
- 48 GB memory or more—6,000 virtual servers.

The proxy limits vary based on the amount of system RAM:

- Less than 48 GB memory— 2,000 proxies.
- 48 GB memory or more—6,000 proxies.

For more information about monitoring the system, see [Monitoring LineRate](#).

#### Default Setting

None

#### Command Mode

exec

## Syntax

**show proxy statistics**

Display load balancer statistics

**show proxy statistics detailed**

Display detailed load balancer statistics

**show proxy limits**

Display load balancer limits; limits vary based on the amount of system RAM

## Examples

**show proxy statistics**

```
Proxy Clients
Open Connections: 0
Total Input Traffic (1 min avg): 0.000 bits/sec
Total Output Traffic (1 min avg): 0.000 bits/sec
SSL Input Traffic (1 min avg): 0.000 bits/sec
SSL Output Traffic (1 min avg): 0.000 bits/sec
New Connection Rate: 0 connections/sec
HTTP Request Rate: 0 requests/sec
Proxy Servers
Open Connections: 0
Input Traffic (1 min avg): 0.000 bits/sec
Output Traffic (1 min avg): 0.000 bits/sec
```

**show proxy statistics detailed**

```
Proxy Global Statistics
eventLoopTime: 0.000000
eventLoopTime 1 Min Avg: 0.000000
eventLoopTime 5 Min Avg: 0.000000
keventTime: 0.000000
keventTime 1 Min Avg: 0.624966
keventTime 5 Min Avg: 0.624993
connClientOpen: 0
connClientReadSize: 0.000000
connClientReadSize 1 Min Avg: 0.000000
connClientReadSize 5 Min Avg: 0.000000
connClientWriteSize: 0.000000
connClientWriteSize 1 Min Avg: 0.000000
connClientWriteSize 5 Min Avg: 0.000000
connAcceptMax: 0.000000
connAcceptMax 1 Min Avg: 0.000000
connAcceptMax 5 Min Avg: 0.000000
connAccepted: 0.000000
connAccepted 1 Min Avg: 0.000000
connAccepted 5 Min Avg: 0.000000
connAcceptReportedAvail: 0.000000
connAcceptReportedAvail 1 Min Avg: 0.000000
```

```
connAcceptReportedAvail 5 Min Avg: 0.000000
httpClientRequestLatency: 0.000000
httpClientRequestLatency 1 Min Avg: 0.000000
httpClientRequestLatency 5 Min Avg: 0.000000
httpClientRespLatency: 0.000000
httpClientRespLatency 1 Min Avg: 0.000000
httpClientRespLatency 5 Min Avg: 0.000000
httpClientRespInitLatency: 0.000000
httpClientRespInitLatency 1 Min Avg: 0.000000
httpClientRespInitLatency 5 Min Avg: 0.000000
httpClientXactionLatency: 0.000000
httpClientXactionLatency 1 Min Avg: 0.000000
httpClientXactionLatency 5 Min Avg: 0.000000
connClientBytesRx: 0
connClientBytesRx/sec: 0
connClientBytesRx/sec 1 Min Avg: 0
connClientBytesRx/sec 5 Min Avg: 0
```

[Output continues with many additional lines of detail.]

### **show proxy limits**

```
Maximum Forward Proxies: 0
Maximum Virtual IPs: 2000
Maximum Virtual Servers: 2000
Maximum Real Servers: 8000
```

### **Related**

[Proxy Mode Commands](#)

REST API Reference - [stats](#)

REST API Reference - [limits](#)

---

## Show Real Server Commands

1. [show real-server](#)
2. [show real-server group](#)
3. [show real-server route](#)
4. [show real-server statistics](#)

Use the following commands to display information about real servers.

---

### show real-server

#### Use

Use to display general information about existing real servers.

For the `show real-server <rs_name>` command, the third column shows that the configuration comes from of the following:

- set locally—The setting is configured directly for the real server.
- inherited from <base\_name>—The setting is inherited from the listed real server base.
- default—The setting is not configured directly for the real server or in the real server base.

The `show real-server <rs_name> health` command, shows the following:

- Status—The status can be one of the following:
  - down—Based on the health monitor's probes, the real server is down.
  - up—Based on the health monitor's probes, the real server is up.
  - up (mon off)—System cannot determine the status of the real server, because the health monitor's admin status is offline. The system assumes the real server is up.
- History—Shows the result of the last 50 health monitor probes, as follows (most recent probe last):
  - p—Shows the probe passed.
  - .—Shows the probe failed.

#### Default Setting

None

#### Command Mode

exec

## Syntax

**show real-server <rs\_name>**

Show the configuration and status of the specified real server

**show real-server brief**

Show summary of real server configuration, status, and current statistics (snapshot at the time you ran the command)

**show real-server <rs\_name> health**

Shows real server health information

| Parameter | Type | Description              |
|-----------|------|--------------------------|
| rs_name   | Word | Name of the real server. |

## Examples

**show real-server rsweb1**

Configuration

```
Address:                10.1.2.101:8080    set locally
Admin Status:           online          inherited from rsbase_web
Max. Connections:       1000          inherited from rsbase_web
TCP Options:            <none>          default
SSL Profile:            ssl_prof_init1    inherited from rsbase_web
Service Type:           http            inherited from rsbase_web
Health Monitors:
  Name                   Svc           Admin          SSL Profile
  hm_web1                http          online         <unset>
Max. Request In Flight: 1             default
Keepalive Timeout:      10 s         inherited from rsbase_web
Response Timeout:       60 s         inherited from rsbase_web
Response Idle Timeout:  60 s         inherited from rsbase_web
Request Idle Timeout:   0 s          default
Tunnel Idle Timeout:    0 s          default
Is Proxy:               0             default
Request Rate Limit:     0 reqs/sec
Request Rate Limit Burst Size: <auto>
```

Current Status

Health Status: down

**show real-server brief**

| Name   | Address    | Port | Svc  | Admin  | Health | Conns | Rx Mbps | Tx Mbps |
|--------|------------|------|------|--------|--------|-------|---------|---------|
| rsweb1 | 10.1.2.101 | 8080 | http | online | down   | 0     | 0.0     | 0.0     |
| rsweb2 | 10.1.2.102 | 8080 | http | online | down   | 0     | 0.0     | 0.0     |

**show real-server rsweb1 health**

Status: up



## Related Commands

[Real Server Mode Commands](#)

---

# show real-server route

## Use

Use to display information about real server routes.

## Default Setting

None

## Command Mode

exec

## Syntax

```
show real-server route
```

Show summary of routes to all real servers, with the IP address of each real server and the gateway to each real server

## Example

```
show real-server route
```

```
Name Address Gateway Intf MTU
-----
rsweb1 10.1.2.101 - em2 1500

rsweb2 10.1.2.102 - em2 1500
```

## Related Commands

[Real Server Mode Commands](#)

---

# show real-server statistics

## Use

Use to display a snapshot of various statistics related to real server traffic and connections. The statistics only show the initiation side of connections.

## Default Setting

None

## Command Mode

exec

## Syntax

```
show real-server <rs_name> statistics
```

Shows statistics related to a real server

```
show real-server <rs_name> statistics connection-errors
```

Shows real server connection error statistics. If you see a lot of errors, you should investigate the cause.

```
show real-server <rs_name> statistics connections
```

Shows real server connection statistics

```
show real-server <rs_name> statistics detailed
```

Shows all statistics related to a real server

```
show real-server <rs_name> statistics http-requests
```

Shows real server HTTP request statistics

```
show real-server <rs_name> statistics http-response-codes
```

Shows real server HTTP response code statistics

```
show real-server <rs_name> statistics http-responses
```

Shows real server HTTP response statistics

```
show real-server <rs_name> statistics server-latency
```

Shows real server latency statistics

```
show real-server <rs_name> statistics traffic
```

Shows real server traffic statistics

| Parameter | Type | Description              |
|-----------|------|--------------------------|
| rs_name   | Word | Name of the real server. |

## Examples



**show real-server rsweb1 statistics**

Connections  
Open: 0  
Opened: 0 connections/sec  
Connection Errors  
Timed out: 0  
Lost: 0  
Reset: 0  
Refused: 0  
Addr In Use: 0  
Idle timeout: 0  
Traffic  
L7 Receive: 0 bits/sec  
L7 Send: 0 bits/sec  
HTTP Requests  
Request Rate: 0 requests/sec  
Total: 0  
Queue Size: 0  
HTTP Responses  
Response Rate: 0 responses/sec  
Errored: 0  
Server Latency  
Transaction: 0 s  
Connect Tunnels  
Open: 0  
Opened Rate: 0 tunnels/sec

**show real-server rsweb1 statistics connection-errors**

Connection Errors  
Timed out: 0  
Lost: 0  
Reset: 0  
Refused: 0  
Addr In Use: 0  
Idle timeout: 0  
Server Closed Early: 0  
Client Closed Early: 0

**show real-server rsweb1 statistics connections**

Connections  
Open: 0  
Opened: 0 connections/sec  
1 Min Average: 0 connections/sec  
5 Min Average: 0 connections/sec  
Total Opened: 0  
Closed: 0  
Need More Conns: 0  
Initiated: 0

**show real-server rs1 statistics http-requests**

HTTP Requests  
Request Rate: 0 requests/sec

1 Min Average: 0 requests/sec  
5 Min Average: 0 requests/sec  
Total: 0  
Abandoned: 0  
Queue Size: 0  
1 Min Average: 0  
5 Min Average: 0  
Timed Out: 0

**show real-server rsl statistics http-response-codes**

HTTP Response Codes Count % of total count

100: 0 0  
101: 0 0  
102-199: 0 0  
200: 0 0  
201: 0 0  
202: 0 0  
203: 0 0  
204: 0 0  
205: 0 0  
206: 0 0  
207-299: 0 0  
300: 0 0  
301: 0 0  
302: 0 0  
303: 0 0  
304: 0 0  
305: 0 0  
306: 0 0  
307: 0 0  
308-399: 0 0

[Output continues]

**show real-server rsl statistics http-responses**

HTTP Responses

Response Rate: 0 responses/sec  
1 Min Average: 0 responses/sec  
5 Min Average: 0 responses/sec  
Total: 0  
Good: 0  
Errored: 0  
Extraneous: 0  
Abandoned: 0  
Timed Out: 0  
Idle Timed Out: 0  
Error receiving body: 0

**show real-server rsl statistics server-latency**

Server Latency

Transaction: 0 s  
1 Min Average: 0 s  
5 Min Average: 0 s  
Request: 0 s  
1 Min Average: 0 s

5 Min Average: 0 s  
Initial: 0 s  
1 Min Average: 0 s  
5 Min Average: 0 s  
Response: 0 s  
1 Min Average: 0 s  
5 Min Average: 0 s

**show real-server rsl statistics traffic**  
Traffic

L7 Receive: 0 bits/sec  
1 Min Average: 0 bits/sec  
5 Min Average: 0 bits/sec  
L7 Send: 0 bits/sec  
1 Min Average: 0 bits/sec  
5 Min Average: 0 bits/sec  
L7 Total Received: 0 Bytes  
L7 Total Sent: 0 Bytes  
Avg Read Size: 0 Bytes  
1 Min Average: 0 Bytes  
5 Min Average: 0 Bytes  
Avg Write Size: 0 Bytes  
1 Min Average: 0 Bytes  
5 Min Average: 0 Bytes

**Related Commands**

[Real Server Mode Commands](#)

---

## Show REST Server Commands

---

### show rest-server

#### Use

Use to display configuration and status information about the REST server.

#### Default Setting

None

#### Command Mode

exec

#### Syntax

```
show rest-server
```

Show information about the HTTP server for REST API access

#### Example

```
show rest-server
Configuration
Listening Interfaces:
0.0.0.0:8443
[::]:8443
Remote Addresses:
any
SSL Profile: self-signed
Logging: 0
Session Idle Timeout: 3.6 ks
Current Status
UP
```

#### Related

[REST Server Mode Commands](#)

REST API Reference - [restServer](#)

---

## Show Running Config Commands

1. [show running-config](#)

---

### show running-config

#### Use

Use to view the configuration you are currently running, including changes you have made since you last saved the configuration. The system has a default running config that it runs if it cannot find a startup config.

#### Default Setting

Default settings in the default running config are described in each command section.

#### Command Mode

exec

#### Syntax

```
show running-config
```

Shows the whole running configuration.

```
show running-config brief
```

Show the running configuration without IP filters and certificate and key data.

```
show running-config diffs
```

Show the differences from startup-config.

```
show running-config redacted
```

Show the configuration with sensitive values (passwords, keys) redacted.

#### Example

```
show running-config brief
```

Building configuration...

```
!  
hostname example-host  
!  
username admin secret encrypted "$2a$04$7TYufYOKVQ8i8bblVtZ1ierxZXzcH5mR/  
QeaZH8WnWRzVEkPt0MgS" uid 2000  
!  
interface em0  
ip address 10.0.2.15 255.255.255.0  
ip address 10.200.0.1 255.255.255.0  
!  
interface em1  
ip address 192.0.2.1 255.255.255.0  
!  
interface em2  
ip address 10.1.2.1 255.255.255.0  
!  
interface em3  
ip address 0.0.0.0 255.0.0.0  
ip address 10.126.1.242 255.255.0.0  
!  
ip route 0.0.0.0/0 192.0.2.2  
!  
health-monitor hm_web1  
interval 5  
timeout 1  
server-down "8/10"  
server-up "9/10"  
type http  
request-method GET  
request-target "/health.html"  
admin-status online  
!  
ssl profile self-signed  
attach primary-certificate self-signed  
attach private-key self-signed  
!  
ssl profile ssl_prof_init1  
!  
ssl profile ssl_prof_secure.example.com  
attach primary-certificate cert_prim_secure.example.com  
attach private-key key_secure.example.com  
attach chain-certificate cert_chain_secure.example.com1
```

```
!  
real-server base rsbase_web  
admin-status online  
max-connections 1000  
service http  
response-timeout 60  
response-idle-timeout 60  
keepalive-timeout 10  
attach ssl profile ssl_prof_init1  
attach health-monitor hm_web1  
!  
real-server rsweb1 ip 10.1.2.101 8080 base rsbase_web  
real-server rsweb2 ip 10.1.2.102 8080 base rsbase_web  
!  
virtual-ip base vipbase_web1  
admin-status online  
service http  
keepalive-timeout 5  
!  
virtual-ip vipweb1  
ip address 192.0.2.1 80  
base vipbase_web1  
attach ssl profile ssl_prof_secure.example.com  
!  
real-server group rsgroup_websilo1  
members by regex "rsweb.*"  
!  
virtual-server websilo1  
lb-algorithm round-robin-free  
service http  
attach virtual-ip vipweb1 default  
attach real-server group rsgroup_websilo1  
!  
ssh  
allow from 10.200.0.0/24  
allow from 10.0.2.0/24  
allow to 10.200.0.1 22  
allow to 10.0.2.15 22  
!  
rest-server  
allow from any  
allow to any 8443  
attach ssl profile self-signed
```

```
!  
license-manager  
ip 1 10.126.64.38  
!  
certificate cert_chain_secure.example.com1  
! Cert data not shown in brief output  
!  
certificate cert_prim_secure.example.com  
! Cert data not shown in brief output  
!  
certificate self-signed  
! Cert data not shown in brief output  
!  
certificate bundle cert_bndlsecure.example.com  
! Cert data not shown in brief output  
!  
key key_secure.example.com  
! Key data not shown in brief output  
!  
key self-signed  
! Key data not shown in brief output
```

### **show running-config diffs**

Building configuration...

```
--- startup-config  
+++ running-config  
@@ -14,10 +14,15 @@  
ip address 10.1.2.1 255.255.255.0  
!  
interface em3  
+ ip address 0.0.0.0 255.0.0.0  
ip address 10.126.1.242 255.255.0.0  
!  
ip route 0.0.0.0/0 192.0.2.2  
!  
+health-monitor hm2  
+ override-port 20  
+ attach ssl profile ssl_prof_init1  
+!  
health-monitor hm_web1  
interval 5  
timeout 1
```



## **Related**

Getting Started Guide - [Complete Example Show Run Output](#)

Getting Started Guide - [Running Config and Startup Config](#)

Getting Started Guide - [Show Startup Config Commands](#)

REST API Reference - [running](#)

---

## Show Scripting Commands

1. [show scripting](#)

---

### show scripting

#### Use

Use to display information about the scripting system, including the installed Node Packaged Modules.



**Note:** If you enable an F5<sup>®</sup> LineRate Point<sup>™</sup> Load Balancer license, you can configure scripts and script-related functions, such as npm, but the scripts will not run. You will need to upgrade to an F5<sup>®</sup> LineRate Precision<sup>™</sup> Load Balancer license for full scripting functionality. Upon upgrade, all configured scripts with valid source and admin status set to online will start.

---

#### Default Setting

None

#### Command Mode

exec

#### Syntax

```
show scripting packages bundled
```

Show packages bundled with the system

```
show scripting packages bundled <module_name>
```

Show packages bundled with the system

```
show scripting packages user
```

Show information about packages installed by users

```
show scripting packages user <module_name>
```

Show information about packages installed by users

## **show scripting version**

Show versions of scripting engines

| Parameter    | Type | Description             |
|--------------|------|-------------------------|
| rmodule_name | Word | Name of bundled module. |

## **Examples**

### **show scripting packages bundled**

```
Package Version Description
```

```
-----
```

```
redis 0.8.2 Redis client library
```

### **show scripting packages bundled <module\_name>**

```
Version: 0.8.2
```

```
Description:
```

```
Redis client library
```

```
Dependencies:
```

```
redis@0.8.2/usr/linerate/node/scripting/node_modules/redis
```

```
+-- (empty)
```

### **show scripting packages user**

```
Package Version Description
```

```
-----
```

```
mysql 2.0.0-alpha8 A node.js driver for mysql. It is written in Ja...
```

```
underscore 1.5.1 JavaScript's functional programming helper libr...
```

### **show scripting packages user <module\_name>**

```
Version: 2.0.0-alpha8
```

```
Description:
```

```
A node.js driver for mysql. It is written in JavaScript, does not require  
compiling, and is 100% MIT licensed.
```

```
Dependencies:
```

```
mysql@2.0.0-alpha8/home/linerate/data/scripting/lib/node_modules/mysql
```

```
|-- bignumber.js@1.0.1
```

```
+-- require-all@0.0.3
```

## **show scripting version**

```
Node API compatibility version: 0.8.3  
LineRate Scripting engine version: 0.1.0
```

## **Related**

CLI Reference - [Scripting Mode Commands](#)

REST API Reference - [scripting](#)

---

## Show Script Commands

1. [show script](#)

Use the following commands to display information about scripts.

---

### show script

#### Use

Use to display information about existing scripts.

---



**Note:** If you enable an F5<sup>®</sup> LineRate Point<sup>™</sup> Load Balancer license, you can configure scripts and script-related functions, such as npm, but the scripts will not run. You will need to upgrade to an F5<sup>®</sup> LineRate Precision<sup>™</sup> Load Balancer license for full scripting functionality. Upon upgrade, all configured scripts with valid source and admin status set to online will start.

---

The Last Error field (`show script <script_name>`) reflects the last error this script encountered, regardless of environmental changes that fixed the cause of the error. The script may be currently running properly, but the last error remains. Administrative action on the script is required to clear this error: explicitly clearing the error using `admin-status offline`, then `admin-status online` for the script, changing the script, or replacing with a new script.

The Cert-Bundle field (`show script brief`) can display the following:

| Field text       | Definition  |
|------------------|---|
| <default>        | Script is using the system root certificate bundle, which may be the default or a custom system root certificate bundle. No custom certificate bundle is configured for the script. |
| ScriptCertBundle | Script is using the custom certificate bundle called ScriptCertBundle.  |

The Root Cert Bundle field (`show script <script_name>`) can display the following:

| Field text                           | Definition   |
|--------------------------------------|--|
| default system bundle<br><default>   | Script is using the default system root certificate bundle. No custom certificate bundle is configured for the system or script.                           |
| NewSystemRootCertBundle<br><default> | System is using the custom system root certificate bundle called NewSystemRootCertBundle. No certificate bundle is configured specifically for the script. |
| ScriptCertBundle                     | Script is using the custom certificate bundle called ScriptCertBundle.   |

### Default Setting

None

### Command Mode

exec

### Syntax

**show script <script\_name>**

Show information about the specified script.

**show script <script\_name> statistics**

Shows statistics related to the specified script.

**show script <script\_name> statistics detailed**

Shows all detailed statistics related to the specified script.

**show script brief**

Show summary information for all configured scripts.

| Parameter   | Type | Description         |
|-------------|------|---------------------|
| script_name | Word | Name of the script. |

### Examples

**show script add-proxyhost**

Admin Status: online  
Restart Mode: manual  
Root Cert Bundle: <default>

Created At: Tue Oct 22 17:55:05 2013 UTC

Attached Entities:

Proxy Request Listeners

| Name | Count |
|------|-------|
| vs1  | 2 / 5 |

Per-process Properties:

Busy Timeouts

| Timeout | Count | Status |
|---------|-------|--------|
| 1.063s  | 1 / 5 |        |
| 1.604s  | 1 / 5 |        |
| 1.605s  | 1 / 5 |        |
| 1.606s  | 1 / 5 |        |
| 1.607s  | 1 / 5 |        |

Status: DOWN: syntax error

Last Error

Timestamp: Tue Oct 22 17:56:31 2013 UTC

Stage: compile

Message:

encountered the following errors when compiling script  
add-proxyhost:1: SyntaxError: Unexpected token ;  
a = ;  
^

**show script add-proxyhost statistics**

Proxy

Requests Redirected: 0

Request Events: 0

TCP Connections

Listening: 0

Open Server: 0

Open Client: 0

Timers

Pending: 0

Miscellaneous

Unrecoverable exceptions: 0

Auto-restarts: 0

## show script add-proxyhost statistics detailed

### Proxy

Requests Redirected: 0

Request Events: 0

### TCP Connections

Listening: 0

Open Server: 0

Open Client: 0

### Timers

Pending: 0

### Miscellaneous

Unrecoverable exceptions: 0

Auto-restarts: 0

LROS(config)# show script add-proxyhost statistics detailed

### Proxy

Requests Redirected: 0

Request Events: 0

### TCP Connections

Listening: 0

Open Server: 0

Open Client: 0

### Timers

Pending: 0

### Miscellaneous

Unrecoverable exceptions: 0

Auto-restarts: 0

## show script brief

| Name          | Admin | Status        | Cert-Bundle    | Rstrt-mode | Excpt | Rstrt | Req- |
|---------------|-------|---------------|----------------|------------|-------|-------|------|
| Listeners     |       |               |                |            |       |       |      |
| -----         |       |               |                |            |       |       |      |
| -----         |       |               |                |            |       |       |      |
| add-proxyhost | off   | DOWN:compiled | <default>      | auto       | 0     | 0     |      |
| <none>        |       |               |                |            |       |       |      |
| test_script   | off   | DOWN:admin    | CertBundScript | auto       | 0     | 0     |      |
| <none>        |       |               |                |            |       |       |      |

## Related

[Script Mode Commands](#)



---

## Show SNMP Commands

1. [show snmp-server](#)

---

### show snmp-server

#### Use

Use to view the the SNMP configuration.

#### Default Setting

None

#### Command Mode

exec

#### Syntax

```
show snmp-server host <host_name>
```

Display information about host where SNMP traps are to be sent

```
show snmp-server host <host_name> community
```

Display community token

```
show snmp-server host <host_name> ip
```

Display IP address

```
show snmp-server host <host_name> notification-type
```

Display notification types enabled

```
show snmp-server host <host_name> udp-port
```

Display UDP port

```
show snmp-server host brief
```

Display summary of all hosts

`show snmp-server host detailed`

Display details of all hosts

| Parameter | Type   | Description                                 |
|-----------|--------|---|
| host_name | String | Display information for the specified host. |

### Related

CLI Reference - [SNMP Mode Commands](#)

REST API Reference - [snmp](#)

---

## Show SSL Commands

1. [show ssl ecc-curves](#)
2. [show ssl profile <profile\\_name>](#)
3. [show ssl statistics](#)

---

### show ssl ecc-curves

#### Use

Use to view the list of supported ECC curves.

#### Default Setting

List of supported ECC curves

#### Command Mode

exec

#### Syntax

```
show ssl ecc-curves
```

Shows information on SSL profiles

#### Example

```
show ssl ecc-curves
```

| Name      | Description                                |
|-----------|--|
| secp112r1 | SECG/WTLS curve over a 112 bit prime field |
| secp112r2 | SECG curve over a 112 bit prime field      |
| secp128r1 | SECG curve over a 128 bit prime field      |
| secp128r2 | SECG curve over a 128 bit prime field      |
| secp160k1 | SECG curve over a 160 bit prime field      |
| secp160r1 | SECG curve over a 160 bit prime field      |
| secp160r2 | SECG/WTLS curve over a 160 bit prime field |
| secp192k1 | SECG curve over a 192 bit prime field      |

|                        |  |
|------------------------|--|
| secp224k1              | SECG curve over a 224 bit prime field            |
| secp224r1              | NIST/SECG curve over a 224 bit prime field       |
| secp256k1              | SECG curve over a 256 bit prime field            |
| secp384r1              | NIST/SECG curve over a 384 bit prime field       |
| secp521r1              | NIST/SECG curve over a 521 bit prime field       |
| prime192v1             | NIST/X9.62/SECG curve over a 192 bit prime field |
| prime192v2             | X9.62 curve over a 192 bit prime field           |
| prime192v3             | X9.62 curve over a 192 bit prime field           |
| prime239v1             | X9.62 curve over a 239 bit prime field           |
| prime239v2             | X9.62 curve over a 239 bit prime field           |
| prime239v3             | X9.62 curve over a 239 bit prime field           |
| prime256v1             | X9.62/SECG curve over a 256 bit prime field      |
| wap-wsg-idm-ecid-wtls6 | SECG/WTLS curve over a 112 bit prime field       |
| wap-wsg-idm-ecid-wtls7 | SECG/WTLS curve over a 160 bit prime field       |
| wap-wsg-idm-ecid-wtls8 | WTLS curve over a 112 bit prime field            |
| wap-wsg-idm-ecid-wtls9 | WTLS curve over a 160 bit prime field            |

---

## show ssl profile <profile\_name>

### Use

Use to display information about the specified SSL profile.

### Default Setting

None

### Command Mode

exec

### Syntax

**show ssl profile <profile\_name>**

Shows information on SSL profiles

**show ssl profile <prof\_name> statistics**

Show statistics for the given SSL profile

| Parameter    | Type | Description              |
|--------------|------|--------------------------|
| profile_name | Word | Name of the SSL profile. |

## Example

### show ssl profile self-signed

Configuration:

Primary Certificates:

| Name        | Origin      | Type | Matching Key | In |
|-------------|-------------|------|--------------|----|
| self-signed | set locally | RSA  | self-signed  |    |

Yes

Private Keys:

| Name        | Origin      | Type | Matching Certificates |
|-------------|-------------|------|-----------------------|
| self-signed | set locally | RSA  | self-signed           |

Chained Cert Name:

<none>

Disabled Protocols List: SSLv2:SSLv3 default

Cipher List: HIGH:!ADH:!SSLv2:!PSK:!ECDH:!kEDH:!SRP:+AES:+3DES default

ECC Curve List: prime256v1 default

SSL Session Cache Mode: auto size default

SSL Session Cache Size: 10 Mi default

SSL Session Tickets Mode: enabled default

Active Protocols: TLSv1:TLSv1.1:TLSv1.2

Ordered Cipher List:

| Name              | Certificate | Key         |
|-------------------|-------------|-------------|
| AES256-GCM-SHA384 | self-signed | self-signed |
| AES256-SHA256     | self-signed | self-signed |
| AES256-SHA        | self-signed | self-signed |
| AES128-GCM-SHA256 | self-signed | self-signed |
| AES128-SHA256     | self-signed | self-signed |
| AES128-SHA        | self-signed | self-signed |
| DES-CBC3-SHA      | self-signed | self-signed |

## Related

[SSL Mode Commands](#)

REST API Reference - [ssl](#)

---

# show ssl statistics

## Use

Use to display SSL statistics, aggregated across all profiles.

## Default Setting

None

## Command Mode

exec

## Syntax

```
show ssl statistics
```

Show aggregate SSL statistics across all profiles

## Example

```
LROS# show ssl statistics
Statistics
Session Ticket Successes (Termination): 0
Session Ticket Failures (Termination): 0
Session Cache Hits (Termination): 0
Session Cache Misses (Termination): 0
Cached Session Expired (Termination): 0
Sessions Reused (Termination): 0
Sessions negotiated without reuse (Termination): 0
Sessions Reused (Initiation): 0
Sessions negotiated without reuse (Initiation): 0
```

## Related

[SSL Mode Commands](#)

---

## Show Startup Config Commands

1. [show startup-config](#)

---

### show startup-config

#### Use

Use to view the saved configuration that the system will use when you next restart the F5<sup>®</sup> LineRate<sup>®</sup> software.

#### Default Setting

None

#### Command Mode

exec

#### Syntax

```
show startup-config
```

Shows the saved configuration.

#### Example

```
show startup-config
```

```
example-host# show start
!
hostname example-host
!
username admin secret encrypted "$2a$04$7TYufYOKVQ8i8bb1VtZ1ierxZXzcH5mR/
QeaZH8WnWRzVEkPt0MgS" uid 2000
!
interface em0
ip address 10.0.2.15 255.255.255.0
ip address 10.200.0.1 255.255.255.0
!
```

```
interface em1
ip address 192.0.2.1 255.255.255.0
!
interface em2
ip address 10.1.2.1 255.255.255.0
!
interface em3
ip address 10.126.1.242 255.255.0.0
!
ip route 0.0.0.0/0 192.0.2.2
!
health-monitor hm_web1
interval 5
timeout 1
server-down "8/10"
server-up "9/10"
type http
request-method GET
request-target "/health.html"
admin-status online
!
ssl profile self-signed
attach primary-certificate self-signed
attach private-key self-signed
!
ssl profile ssl_prof_init1
!
ssl profile ssl_prof_secure.example.com
attach primary-certificate cert_prim_secure.example.com
attach private-key key_secure.example.com
attach chain-certificate cert_chain_secure.example.com1
!
real-server base rsbase_web
admin-status online
max-connections 1000
service http
response-timeout 60
response-idle-timeout 60
keepalive-timeout 10
attach ssl profile ssl_prof_init1
attach health-monitor hm_web1
!
real-server rsweb1 ip 10.1.2.101 8080 base rsbase_web
```



```
real-server rsweb2 ip 10.1.2.102 8080 base rsbase_web
!
virtual-ip base vipbase_web1
admin-status online
service http
keepalive-timeout 5
!
virtual-ip vipweb1
ip address 192.0.2.1 80
base vipbase_web1
attach ssl profile ssl_prof_secure.example.com
!
real-server group rsgroup_websil01
members by regex "rsweb.*"
!
virtual-server websil01
lb-algorithm round-robin-free
service http
attach virtual-ip vipweb1 default
attach real-server group rsgroup_websil01
!
ssh
allow from 10.200.0.0/24
allow from 10.0.2.0/24
allow to 10.200.0.1 22
allow to 10.0.2.15 22
!
rest-server
allow from any
allow to any 8443
attach ssl profile self-signed
!
license-manager
ip 1 10.126.64.38
!
certificate cert_chain_secure.example.com1
pem-format
-----BEGIN CERTIFICATE-----
MIIDUDCCAjgCAQEwDQYJKoZIhvcNAQEFBQAwaDELMAkGA1UEBhMCVVMxETAPBgNV
! ...
-----END CERTIFICATE-----
quit
!
```

```
certificate cert_prim_secure.example.com
pem-format
-----BEGIN CERTIFICATE-----
MIIDUTCCAjkCAQEwDQYJKoZIhvcNAQEFBQAwdDELMAkGA1UEBhMCVVMxETAPBgNV
! ...
-----END CERTIFICATE-----
quit
!
certificate self-signed
pem-format
-----BEGIN CERTIFICATE-----
MIIDojCCAiKgAwIBAgIJAPm1YLOdNan3MA0GCSqGSIb3DQEBBQUAMBwxGjAYBgNV
! ...
-----END CERTIFICATE-----
quit
!
certificate bundle cert_bndlsecure.example.com
pem-format
-----BEGIN CERTIFICATE-----
MIIEkDCCA/mgAwIBAgIQGwk7eGCW2je7pFGURsiWeDANBgkqhkiG9w0BAQUFADBf
! ...
-----END CERTIFICATE-----
-----BEGIN CERTIFICATE-----
MIIGKTCBRGgAwIBAgIQZBvoIM4CCBPzLU0tldZ+ZzANBgkqhkiG9w0BAQUFADCB
! ...
-----END CERTIFICATE-----
-----BEGIN CERTIFICATE-----
MIIF7DCCBNSgAwIBAgIQbsx6pacDIAm4zrz06VLUkTANBgkqhkiG9w0BAQUFADCB
! ...
-----END CERTIFICATE-----
quit
!
key key_secure.example.com
pem-format
-----BEGIN RSA PRIVATE KEY-----
MIIEowIBAAKCAQEAA7beACBTJLlEEE3qaf+qBg7P5Igz2zzdY22pbZ0wO2vGaZK2R
! ...
-----END RSA PRIVATE KEY-----
quit
!
key self-signed
pem-format
-----BEGIN RSA PRIVATE KEY-----
```

```
MIIEowIBAAKCAQEAvhALFtrOHMGc9bgYcFB5spZFVrH2SF8+lan5hsnO1ejXB5Nx
! ...
-----END RSA PRIVATE KEY-----
quit
```

## **Related**

[Running Config and Startup Config](#)

[Show Running Config Commands](#)

REST API Reference - [startup](#)

## Show System Commands

1. [show system](#)

### show system

#### Use

Use to show system information, including capabilities, how kernel exceptions are handled, and the system root certificate bundle.

Use to the system capabilities view the capabilities for your F5<sup>®</sup> LineRate<sup>®</sup> system.

For REST, each node below the capabilities node is a specific capability (/status/system/capabilities/<capability>). Each capability node is not shown in this documentation.

The capabilities are:

| Capability   | Description  |
|--------------|--|
| bootSettings | Ability to configure boot version                          |
| carp         | Ability to create CARP interfaces                          |
| ipv6         | Environment supports IPv6 addresses                        |
| persist      | State, such as startup-config, is maintained across reboot |
| portChannel  | Ability to create port-channel interfaces                  |
| vlan         | Ability to create VLAN Interfaces                          |

Below each capability REST node are two child nodes:

- disabledReason—Describes why the capability is disabled, for example, the F5<sup>®</sup> LineRate<sup>®</sup> is deployed in a PXE environment.
- unavailableReason—Describes why the capability is not available, for example, the F5<sup>®</sup> LineRate<sup>®</sup> is deployed in a PXE environment.

#### Default Setting

None

## Command Mode

exec

## Syntax

**show system capabilities**

Show a summary of the system capabilities in table format

**show system capabilities <cap>**

Show system capabilities

**show system capabilities detailed**

Show more detailed system capabilities

**show system kernel-exception**

Show how kernel exceptions are handled

**show system platform**

Show a summary of system information

**show system root-cert-bundle**

Shows the certificate bundle that is currently configured as system root certificate bundle

| Parameter | Type   | Description                        |
|-----------|--------|------------------------------------|
| cap       | String | Show a specific system capability. |

## Related

CLI Reference Guide - [System Mode Commands](#)

CLI Reference Guide - [Certificate Mode Commands](#)

REST API Reference Guide - [capabilities](#)

REST API Reference Guide - [rootCertBundle](#)

## Examples

**show system capabilities**

```
Capability      Available  Enabled
```

```

-----
boot-settings NO n/a
carp YES YES
ipv6 YES YES
persist NO n/a
port-channel YES YES
vlan YES YES

```

**show system capabilities "carp"**

```

carp
  Description: Ability to create Carp Interfaces
  Available: YES
  Enabled: YES

```

**show system capabilities detailed**

```

boot-settings
  Description: Ability to configure boot version
  Available: NO - Boot parameters cannot be configured locally in a PXE environment
  Enabled: n/a
carp
  Description: Ability to create Carp Interfaces
  Available: YES
  Enabled: YES
ipv6
  Description: Environment supports IPv6 addresses
  Available: YES
  Enabled: YES
persist
  Description: State such as startup-config be maintained across reboot
  Available: NO - Data will be written to a volatile location that will not persist
on reboot
  Enabled: n/a
port-channel
  Description: Ability to create port-channel interfaces
  Available: YES
  Enabled: YES
vlan
  Description: Ability to create VLAN Interfaces
  Available: YES
  Enabled: YES

```

**show system platform**

```

System Platform
Type: vmware

```

Memory: 8.3215 Gbytes  
Virtual CPUs: 2  
CPU Model: Intel(R) Core(TM) i5-2435M @ 2.40GHz

**show system root-cert-bundle**

System Root Certificate Bundle: default system bundle - System is using the default system root certificate bundle

System Root Certificate Bundle: custom\_bundle - System is using a custom system root certificate bundle called custom\_bundle

---

## Show TCP Commands

1. [show tcp statistics](#)

---

### show tcp statistics

#### Use

Use to view the TCP protocol statistics.

#### Default Setting

None

#### Command Mode

exec

#### Syntax

```
show tcp statistics
```

Shows TCP protocol statistics

#### Example

```
show tcp statistics
```

```
Rcvd: 142024 Total
  0 checksum error, 0 bad offset, 0 too short, 0 invalid
  72072 packet (1158327 bytes) in sequence
  57 dup packets (0 bytes)
  0 partially dup packets (0 bytes)
  0 out-of-order packets (0 bytes)
  0 packets (0 bytes) with data after window
  0 packets after close
  0 window probe packets, 6797 window update packets
  6911 dup ack packets, 0 ack packets with unsent data
  50463 ack packets (1251571 bytes)
Sent: 173290 Total, 0 urgent packets
```



51321 control packets  
58560 data packets (1237978 bytes)  
0 data packets (0 bytes) retransmitted  
63409 ack only packets (21 delayed)  
0 window probe packets, 0 window update packets  
37735 Connections initiated, 6800 connections accepted, 13599 connections established  
44527 Connections closed (including 0 dropped, 967 embryonic dropped)  
14449 Total rxmt timeout, 0 connections dropped in rxmt timeout  
1021 Keepalive timeout, 65 keepalive probe, 956 Connections dropped in keepalive

27 Total open connections  
12 listen, 13 established, 2 syn sent, 0 syn received  
0 last ack, 0 fin wait 1, 0 fin wait 2  
0 close wait, 0 closing, 0 time wait, 0 closed

## **Related**

[TCP Mode Commands](#)

REST API Reference - [tcp](#)

---

## Show Tech Support Commands

1. [show tech-support](#)

---

### show tech-support

#### Use

Use to view information about the system for use by technical support personnel for troubleshooting. For example, the output includes information about the configuration, system information (such as processes running, CPU, memory, and network), various proxy statistics, and much more. To see all of the information, run the CLI command or query the REST node.

#### Default Setting

None

#### Command Mode

exec

#### Syntax

```
show tech-support
```

Show system information useful for LineRate tech support.

```
show tech-support <fileuri>
```

Show system information useful for LineRate tech support.

```
show tech-support detailed
```

Show detailed system information useful for LineRate tech support.

```
show tech-support detailed <fileuri>
```

Show detailed system information useful for LineRate tech support.

| Parameter | Type | Description |
|-----------|------|-------------|
|-----------|------|-------------|

|         |        |   |
|---------|--------|---|
| fileuri | String | URI of a target file for tech-support dump. Protect URIs with quotes (e.g. " <a href="file:///home/linerate/tech-support">file:///home/linerate/tech-support</a> " or " <a href="scp://example.com/tech-support">scp://example.com/tech-support</a> "). |
|---------|--------|---|

### **Related**

REST API Reference - [tech-support](#)



---

## Show Version Commands

1. [show version](#)

---

### show version

#### Use

Use to show the system hardware and software information, including the F5<sup>®</sup> LineRate<sup>®</sup> version.

#### Default Setting

None

#### Command Mode

exec

#### Syntax

```
show version
```

System hardware and software information

#### Example

```
show version
```

```
F5 Networks LROS Version 2.2.0-RC4
  Copyright (c) 2009-2013 F5 Networks, Inc.

  RELEASE IMAGE (1dd189b/3e1441a/b2e5c0d)
  Built Tue Nov 26 20:12:24 MST 2013
  by builder@cayman:/build/cayman/jenkins/workspace/2.2/lrs_release
  Node API compatibility version: 0.8.3
  LineRate Scripting engine version: 0.1.0

  example-host uptime is 17 hours, 19 minutes
```

#### Related

REST API Reference - [version](#)

---

## Show Virtual IP Commands

1. [show virtual-ip](#)
2. [show virtual-ip statistics](#)

---

### show virtual-ip

#### Use

Use to display information about virtual IPs.

#### Default Setting

None

#### Command Mode

exec

#### Syntax

```
show virtual-ip <vip_name>
```

Show information about the specified virtual IP

```
show virtual-ip brief
```

Show summary of virtual IP status

| Parameter | Type | Description             |
|-----------|------|-------------------------|
| vip_name  | Word | Name of the virtual IP. |

#### Examples

```
show virtual-ip vipweb1
Configuration
Address: 192.0.2.1:80 set locally
Admin Status: online inherited from vipbase_web1
SSL Profile: ssl_prof_secure.example.com set locally
Max Conn. Queue Size: <system maximum="maximum"> default <system></system>
```

```
TCP Options: <none> default <none>
IP Filter: <none> default <none>
Service Type: http inherited from vipbase_web1
Max Request In Flight: 1 default
Keepalive Timeout: 5 s inherited from vipbase_web1
Max Request Header Size: 32768 default
Current Status
UP
```

#### **show virtual-ip brief**

```
Name Address Port Svc Admin Conns Rx Mbps Tx Mbps
-----
vipweb1 192.0.2.1 80 http online 0 0.0 0.0
```

### **Related**

[Virtual IP Mode Commands](#)

REST API Reference - [virtualIP](#)

---

## **show virtual-ip statistics**

### **Use**

Use to display snapshot of statistics related to the virtual IP. The statistics only show the termination side of connections (from clients).

### **Default Setting**

None

### **Command Mode**

exec

### **Syntax**

```
show virtual-ip <vip_name> statistics
```

Shows statistics related to a virtual IP

```
show virtual-ip <vip_name> statistics client-latency
```

Shows client latency statistics related to a virtual IP

```
show virtual-ip <vip_name> statistics connection-errors
```

Shows connection-error statistics related to a virtual IP

**show virtual-ip <vip\_name> statistics connections**

Shows connection statistics related to a virtual IP

**show virtual-ip <vip\_name> statistics detailed**

Shows all statistics related to a virtual IP

**show virtual-ip <vip\_name> statistics http-requests**

Shows http request statistics related to a virtual IP

**show virtual-ip <vip\_name> statistics http-response-codes**

Shows http response-code statistics related to a virtual IP

**show virtual-ip <vip\_name> statistics http-responses**

Shows http response statistics related to a virtual IP

**show virtual-ip <vip\_name> statistics traffic**

Shows traffic related to a virtual IP

| Parameter | Type | Description             |
|-----------|------|-------------------------|
| vip_name  | Word | Name of the virtual IP. |

## Examples

**show virtual-ip vipweb1 statistics**

Connections

Open: 0

Opened: 0 connections/sec

Connection Errors

Max Client Conns: 0

Lost - process died: 0

Timed Out: 0

Reset: 0

Refused: 0

Addr In Use: 0

Idle Timeout: 0

Filtered: 0

No Virtual Server: 0

SSL Profile Error: 0

SSL Negotiation Failed: 0

Traffic

L7 Received: 0 bits/sec

L7 Sent: 0 bits/sec

L7 SSL Received: 0 bits/sec

L7 SSL Sent: 0 bits/sec



HTTP Requests  
Total: 0  
Request Rate: 0 requests/sec  
Total errors: 0  
HTTP Responses  
Started: 0  
Completed: 0  
Timed Out: 0  
Idle Timed Out: 0  
LB Forbidden: 0  
LB 5xx Error: 0  
Client Latency  
Transaction: 0 s

**show virtual-ip vipweb1 statistics client-latency**

Client Latency  
Transaction: 0 s  
1 Min Average: 0 s  
5 Min Average: 0 s  
Request: 0 s  
1 Min Average: 0 s  
5 Min Average: 0 s  
Initial: 0 s  
1 Min Average: 0 s  
5 Min Average: 0 s  
Response: 0 s  
1 Min Average: 0 s  
5 Min Average: 0 s

**show virtual-ip vipweb1 statistics connection-errors**

Connection Errors  
Max Client Conns: 0  
Max Client Conns: 0 errors/sec  
1 Min Average: 0 errors/sec  
5 Min Average: 0 errors/sec  
Lost - process died: 0  
Timed Out: 0  
Reset: 0  
Refused: 0  
Addr In Use: 0  
Idle Timeout: 0  
Filtered: 0  
No Virtual Server: 0  
SSL Profile Error: 0  
SSL Negotiation Failed: 0

**show virtual-ip vipweb1 statistics connections**

Connections  
Open: 0  
Opened: 0 connections/sec  
1 Min Average: 0 connections/sec  
5 Min Average: 0 connections/sec  
Total Opened: 0  
Closed: 0

```
SSL Negotiation attempts: 0
SSL Connections Opened: 0
Accept Events: 0 events/sec
1 Min Average: 0 events/sec
5 Min Average: 0 events/sec
Total Accept Events: 0
Accepted per loop: 0
1 Min Average: 0
5 Min Average: 0
Accept Max: 0
1 Min Average: 0
5 Min Average: 0
Available to Accept: 0
1 Min Average: 0
5 Min Average: 0
```

**show virtual-ip vipweb1 statistics http-requests**

```
HTTP Requests
Total: 0
Request Rate: 0 requests/sec
1 Min Average: 0 requests/sec
5 Min Average: 0 requests/sec
Good: 0
Total errors: 0
Connect Requests: 0
Timed Out: 0
```

**show virtual-ip vipweb1 statistics http-response-codes**

```
HTTP Response Codes Count % of total count
100: 0 0
101: 0 0
102-199: 0 0
200: 0 0
201: 0 0
202: 0 0
203: 0 0
204: 0 0
205: 0 0
206: 0 0
207-299: 0 0
300: 0 0
301: 0 0
302: 0 0
303: 0 0
304: 0 0
305: 0 0
306: 0 0
307: 0 0
308-399: 0 0
[Output continues]
```

**show virtual-ip vipweb1 statistics http-responses**

```
HTTP Responses
Started: 0
```

Completed: 0  
Timed Out: 0  
Idle Timed Out: 0  
LB Forbidden: 0  
LB 5xx Error: 0  
LB 5xx Error Rate: 0 errors/sec  
1 Min Average: 0 errors/sec  
5 Min Average: 0 errors/sec  
LB Connects Forbidden: 0

**show virtual-ip vipweb1 statistics traffic**  
Traffic

L7 Received: 0 bits/sec  
1 Min Average: 0 bits/sec  
5 Min Average: 0 bits/sec  
L7 Sent: 0 bits/sec  
1 Min Average: 0 bits/sec  
5 Min Average: 0 bits/sec  
L7 SSL Received: 0 bits/sec  
1 Min Average: 0 bits/sec  
5 Min Average: 0 bits/sec  
L7 SSL Sent: 0 bits/sec  
1 Min Average: 0 bits/sec  
5 Min Average: 0 bits/sec  
L7 Total Received: 0 Bytes  
L7 Total Sent: 0 Bytes  
L7 Total SSL Received: 0 Bytes  
L7 Total SSL Sent: 0 Bytes  
Avg Read Size: 0 Bytes  
1 Min Average: 0 Bytes  
5 Min Average: 0 Bytes  
Avg Write Size: 0 Bytes  
1 Min Average: 0 Bytes  
5 Min Average: 0 Bytes

**Related**

[Virtual IP Mode Commands](#)

---

## Show Virtual Server Commands

1. [show virtual-server](#)
2. [show virtual-server <vs\\_name> persist source-ip cache](#)
3. [show virtual-server statistics](#)

Use the following commands display information about your virtual servers.

---

### show virtual-server

#### Use

Use to view information about existing virtual servers.

For the `show virtual-server brief` command, if you see the Q-size column increasing over time, it may mean that you need additional web servers to handle the client connections.

#### Default Setting

None

#### Command Mode

exec

#### Syntax

```
show virtual-server <vs_name>
```

Show information about a virtual server configuration and status, as well of its virtual IPs and real servers

```
show virtual-server brief
```

Show summary of virtual server status

| Parameter | Type | Description                 |
|-----------|------|-----------------------------|
| vs_name   | Word | Name of the virtual server. |

## Example

```
show virtual-server websilol
```

```
Configuration
```

```
LB Algorithm: round-robin-free
  Service Type: http
  Real Server Groups:
  Name Weight
  rsgroup_websilol 1 (default)
  Real Servers:
  <none>
  Virtual IPs:
  Name Address Port Svc Admin
  vipweb1 192.0.2.1 80 http online
  HTTP Configuration
  TCP Multiplex: 0
  Client IP Header: <none>
  Forward Connect Req: 0
  Session Persistence: Cookie (lrscookie) Expires: 1800s
  Strip Headers:
  <none>
  Hostnames:
  <none>
  Request Rate Limit: <unset>reqs/sec
  Request Rate Limit Burst Size: <auto>
```

```
show virtual-server brief
```

```
Name Svc Req/sec Q-size
```

```
-----
websilol http 0 0
```

## Related

[Virtual Server Mode Commands](#)

---

# show virtual-server <vs\_name> persist source-ip cache

## Use

Use to view the system cache for source IP persistence.



**Note:** Using this command may have a performance impact on connections through the specified virtual server.

---

The cache may contain a large number of entries and may take several seconds to display.

Using the CLI, you can redirect the output to a file using a bash command that runs the F5® LineRate® shell in non-interactive mode. For example:

```
bash
echo "show virtual-server vsfoo persist source-ip cache" | lros_shell -n >
  <file_path>
```

### Default Setting

None

### Command Mode

exec

### Syntax

```
show virtual-server <vs_name> persist source-ip cache
```

List source IP cache entries

| Parameter | Type | Description                 |
|-----------|------|-----------------------------|
| vs_name   | Word | Name of the virtual server. |

### Example

```
show virtual-server vs1 persist source-ip cache
```

WARNING: This operation may take a long time to complete and have an impact on the performance of the source-ip persistence feature. Continue? [yes/no]: **yes**

| Client IP   | Real-Server | Idle since (seconds) |
|-------------|-------------|----------------------|
| 192.168.1.1 | rs1         | 1.111                |
| 192.168.1.2 | rs1         | 3.333                |
| 192.169.1.1 | rs2         | 2.222                |
| 192.169.1.2 | rs2         | 4.444                |

---

## show virtual-server statistics

### Use

Use to display a snapshot of various statistics about virtual server traffic. The statistics show both the initiation and termination sides of the connections.

### Default Setting

None

### Command Mode

exec

## Syntax

**show virtual-server <vs\_name> statistics**

Shows statistics related to a virtual server

**show virtual-server <vs\_name> statistics detailed**

Shows all detailed statistics related to a virtual-server

**show virtual-server <vs\_name> statistics http-requests**

Shows virtual-server http request statistics

**show virtual-server <vs\_name> statistics http-response-codes**

Shows virtual-server http response-code statistics

**show virtual-server <vs\_name> statistics http-responses**

Shows virtual-server http response statistics

**show virtual-server <vs\_name> statistics latency**

Shows virtual-server latency statistics

## Examples

**how virtual-server websilol statistics**

HTTP Requests (Termination Side)

Total: 0

Request Rate: 0 requests/sec

Total errors: 0

HTTP Responses (Termination Side)

Total: 0

Timed Out: 0

Idle Timed Out: 0

LB Forbidden: 0

LB 5xx Error: 0

Client Latency

Transaction: 0 s

HTTP Requests (Initiation Side)

Request Rate: 0 requests/sec

Total: 0

Total Queue Size: 0

HTTP Responses (Initiation Side)

Total: 0

Errored: 0

Server Latency

Transaction: 0 s

Connect Tunnels  
Open: 0  
Opened Rate: 0 tunnels/sec

**show virtual-server websil01 statistics http-requests**

HTTP Requests (Termination Side)

Total: 0  
Request Rate: 0 requests/sec  
1 Min Average: 0 requests/sec  
5 Min Average: 0 requests/sec

Good: 0

Timed Out: 0

Total errors: 0

HTTP Requests (Initiation Side)

Request Rate: 0 requests/sec  
1 Min Average: 0 requests/sec  
5 Min Average: 0 requests/sec

Total: 0

Abandoned: 0

Total Queue Size: 0

1 Min Average: 0

5 Min Average: 0

Request Mgr Q Size: 0

1 Min Average: 0

5 Min Average: 0

Server Q Size: 0

1 Min Average: 0

5 Min Average: 0

Timed Out: 0

**show virtual-server websil01 statistics http-response-codes**

HTTP Response Codes (Initiation Side) Count % of total count

100: 0 0

101: 0 0

102-199: 0 0

200: 0 0

201: 0 0

202: 0 0

203: 0 0

204: 0 0

205: 0 0

206: 0 0

207-299: 0 0

300: 0 0

301: 0 0

302: 0 0

303: 0 0

304: 0 0

305: 0 0

306: 0 0

307: 0 0

308-399: 0 0

**show virtual-server websil01 statistics http-responses**



```
HTTP Responses (Termination Side)
Total: 0
Timed Out: 0
Idle Timed Out: 0
LB Forbidden: 0
LB 5xx Error: 0
LB 5xx Error Rate: 0 errors/sec
1 Min Average: 0 errors/sec
5 Min Average: 0 errors/sec
HTTP Responses (Initiation Side)
Response Rate: 0 responses/sec
1 Min Average: 0 responses/sec
5 Min Average: 0 responses/sec
Total: 0
Good: 0
Errored: 0
Extraneous: 0
Abandoned: 0
Timed Out: 0
Idle Timed Out: 0
Error receiving body: 0
```

#### **show virtual-server websilol statistics latency**

```
Client Latency
Transaction: 0 s
1 Min Average: 0 s
5 Min Average: 0 s
Request: 0 s
1 Min Average: 0 s
5 Min Average: 0 s
Initial: 0 s
1 Min Average: 0 s
5 Min Average: 0 s
Response: 0 s
1 Min Average: 0 s
5 Min Average: 0 s
Server Latency
Transaction: 0 s
1 Min Average: 0 s
5 Min Average: 0 s
Request: 0 s
1 Min Average: 0 s
5 Min Average: 0 s
Initial: 0 s
1 Min Average: 0 s
5 Min Average: 0 s
Response: 0 s
1 Min Average: 0 s
5 Min Average: 0 s
```

#### **Related**

[Virtual Server Mode Commands](#)

---

## Terminal Mode Commands

1. [terminal](#)

---

### terminal

Set terminal parameters.

#### Use

Use set the number of lines per screen in your terminal window for the current CLI session.

Auto setting attempts to change the number of lines when you change the terminal window size. If this does not work the way you want, you can set it to a specific number of lines.

Use `terminal length 0` when sending screen output to a file; the output has no limit.

#### Default Setting

auto

#### Command Mode

exec

#### Syntax

```
terminal length <termLen>
```

Set the number of lines on a screen

```
terminal length auto
```

Try to automatically determine the number of lines per screen for the current terminal

| Parameter | Type    | Description                                   |
|-----------|---------|---|
| termLen   | Integer | Number of lines on screen (0 for no pausing). |

---

## Upgrade Command

Upgrade the system software.

### Use

Use to upgrade LROS software to a new version. The upgrade will retain all of your configuration and lets you roll back to a previously installed software version using either of the following:

- CLI command: `boot system`
- REST node: `/config/system/boot/version`

To subscribe to software release notifications, contact your sales account representative.

Download the upgrade file, which has the extension `.upg.gz`, to the F5<sup>®</sup> LineRate<sup>®</sup> system or to a web server on your intranet. For where to go to download the upgrade file, see [Downloads](#).

If you download the file to a web server on your intranet, you can copy the file to your system one of the following ways:

- Use `scp` to copy the file to the `/home/linerate` directory.
- Use the following REST node: `/exec/system/util/download`.



**Caution:** We recommend upgrading during a maintenance window. The upgrade process causes a system reload. During the reload, you will lose all connections to the F5<sup>®</sup> LineRate<sup>®</sup> system for at least a few minutes.

---

The upgrade command may also be used to roll back to an earlier version of software (to "downgrade") in limited circumstances. If the earlier version of software is already installed, you should use the `boot system` command to switch to that version of software. If the earlier version of software is not installed, the system only supports installing the maintenance release immediately prior to the currently running software version via the upgrade process. To find the prior version of software that can be used with the upgrade process, see the [release notes](#) for your currently running software version.



**Note:** You will need to use your F5<sup>®</sup> login to access release materials.

---



**Note:** When an instance is upgraded in Amazon EC2, AWS will not report any change. AWS will still report the version of the image that the instance was originally launched from. To see the actual running version, use the `show version` command.

## Default Setting

None

## Command Mode

exec

## Syntax

`upgrade`

| Parameter | Type   | Description  |
|-----------|--------|--|
| img       | String | URI of new LROS image file. Enclose URIs in quotes (for example, "file:///home/linerate/LROS-version.upg.gz" or "http://10.1.1.1/software/LROS-version.upg.gz"). |

## Examples

```
upgrade "LROS-1.5.3-R-x64.upg.gz"
```

This command performs an upgrade using the image LROS-1.5.3-R-x64.upg.gz, which is in the default directory, /home/linerate on the F5<sup>®</sup> LineRate<sup>®</sup> system. That upgrade file must already be copied onto the F5<sup>®</sup> LineRate<sup>®</sup> system.

```
upgrade "file:///home/linerate/tmp/LROS-1.5.3-R-x64.upg.gz"
```

This command performs an upgrade using the image LROS-1.5.3-R-x64.upg.gz, which is in the directory /home/linerate/tmp on the F5<sup>®</sup> LineRate<sup>®</sup> system. That upgrade file must already be copied onto the F5<sup>®</sup> LineRate<sup>®</sup> system.

```
upgrade "http://10.1.1.1/lros_images/LROS-1.5.3-R-x64.upg.gz"
```

This command performs an upgrade using the image file LROS-1.5.3-R-x64.upg.gz, which is stored on the intranet web server at 10.1.1.1 in the /lros\_images directory.

## Procedure



## To upgrade F5® LineRate®:

1. Back up your configuration using the backup command.
  - See [Backup Mode Commands](#).
2. Download the upgrade file from <https://linerate.f5.com/downloads> to home/linerate on your F5® LineRate® system.
  - You may see several files available. Be sure to download the version from the email you received. The upgrade file ends in .upg.gz.
  - To copy the image from a system on your local network to the F5® LineRate® system, use a command similar to the following:  

```
scp <local_image.upg.gz> admin@<F5® LineRate®_ip>:/home/linerate/./</local_image.upg.gz>
```
3. From the F5® LineRate® system, type:  
**upgrade**
  - Don't forget to enclose the image name in double quotes.
  - The system tells you that the upgrade requires a reload when complete and asks if you want to continue
4. Type:  
**yes**
  - If you have not saved your running config, the system asks if you want to save it.
5. To save your configuration, type:  
**yes**
  - The upgrade installs. This may take a few minutes. If you are downloading the file and installing the upgrade, it may take longer. The system reloads after the upgrade. When the login prompt displays, the upgrade is complete.
  - After the system comes back up and you log in, you can use the following command to verify the version:  
**show version**

## Related

[Boot Mode Commands](#)

REST API Reference - [upgrade](#)

---

## Write Command

### Use

Use to save the running config to the startup config. See [Running Config and Startup Config](#).

### Default Setting

None

### Command Mode

exec

### Syntax

`write`

Saves the running config to the startup config.

`write memory`

This form of the command does the same thing and is available for compatibility if you are accustomed to other network operating systems.